

2007

AXXAIR

2007

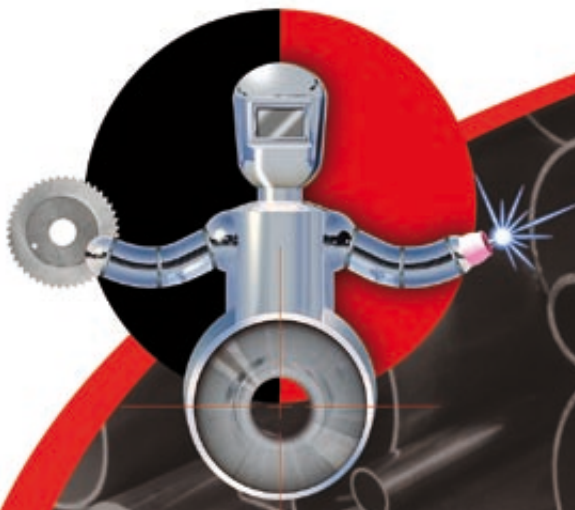
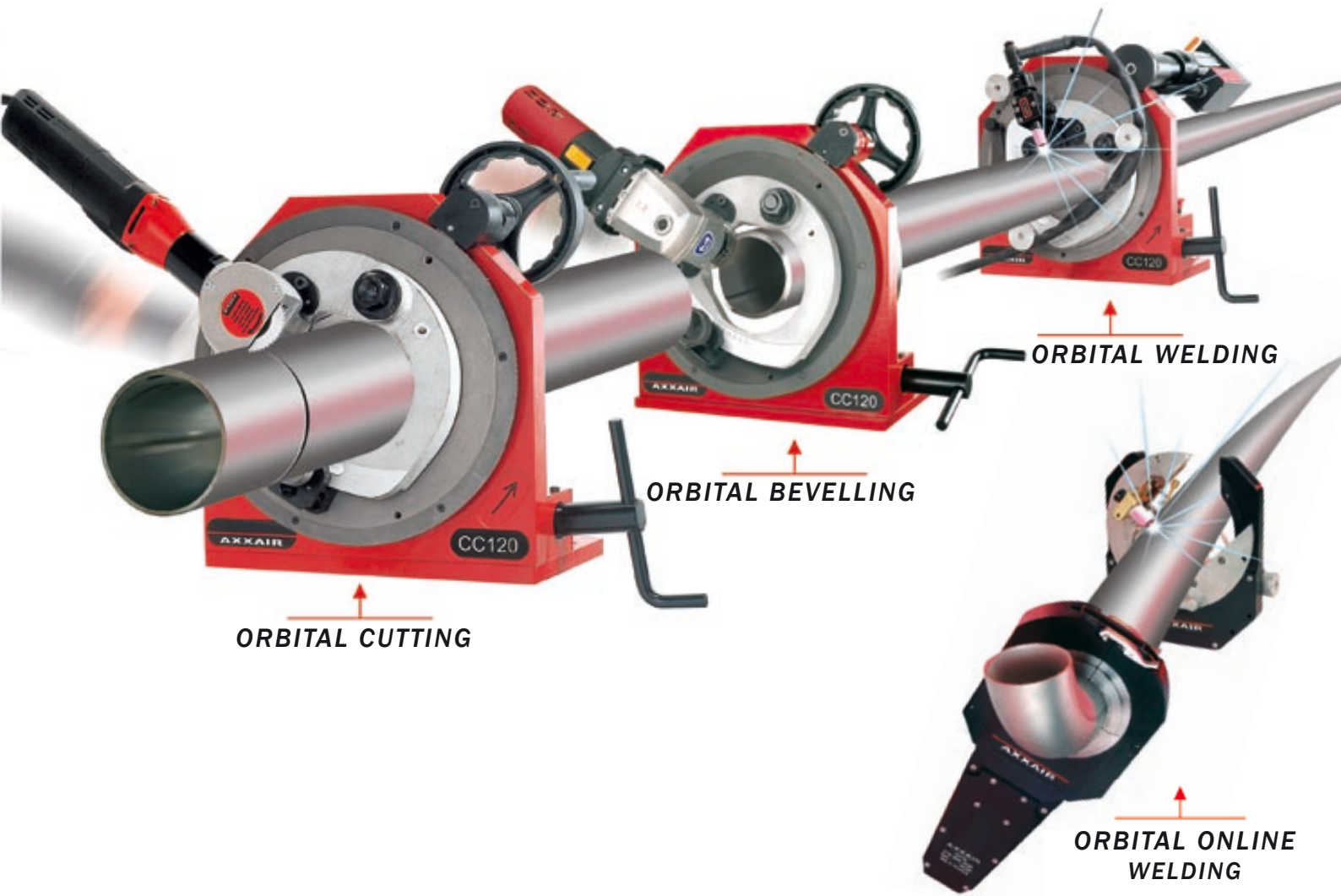

GLOBAL PROCESS



AXXAIR currently offers the market's **LARGEST DIAMETER RANGE**, from 5 mm to 711.2 mm, with 9 models

- **AXXAIR CONCENTRIC PATENTED CLAMPING**, with 3 to 8 **STAINLESS STEEL** jaws, offers the **largest diameter capacity** per model and let minimise the distance from clamping jaw to cutting blade to 15 mm with the basic jaws and 2 mm with extra jaws (according to model). This allows 16 lines of contact to ensure a precise cut without deformation of thin tubes.

- **Interchangeable motors:** 3 choices of motor

Rapid installation of the motor onto the machine body let secure the machine more easily on the worksite (motor delivered in a plastic case)

- **SPEED:** Rapid cut: for example: stainless steel tube 304L 88.9X 2 mm in 20 seconds

Simple and nearly instantaneous adjustment of cut diameter

- **QUALITY:** Cut without tube deformation (concentric multi-contact clamping)

ideal for thin wall stainless tubes. A cut of quality geometry (perpendicularity < 0.25 mm) and a good surface condition (limited burring)

- **PORTABILITY:** Portable machines that are easy to move, just as suitable for use on a worksite as in a workshop.

Ideal preparation for thin wall stainless steel tubes before welding

- **DRIVE WHEEL**, a standard feature: let turn the motor around the tube with gear reduction

Avoid wasted efforts and difficult working positions

Ensures an even advance of the tool, which increases blade lifetime and improves the quality of the cut

- **FLEXIBILITY- PRODUCTIVITY:** AXXAIR bodies (with the exception of CC80 and CCI20 ECO) are quickly and easily adapted to orbital bevelling and welding

GLOBAL PROCESS AXXAIR

ORBITING CUTTING ACCORDING TO AXXAIR



CUTTING MACHINES

CC80

Diameter spread with basic jaws:	Ø 8 mm	⇒	Ø 78 mm
Diameter spread with additional jaws:	Ø 5 mm	⇒	Ø 73 mm
Tube thickness:	0,9 mm	⇒	7 mm
Weight:	17 kg		
3 stainless steel concentric clamping jaws			
Motorization:	M21: 220 V		
Motorization:	M11: 110 V		

“The CC80, because of its overall dimensions and weight, **is the ideal cutting machine for use on worksites** (delivered in a plastic carrying case)”.

CC120 ECO

Diameter spread with basic jaws:	Ø 19 mm	⇒	Ø 121 mm
Diameter spread with additional jaws:	Ø 5 mm	⇒	Ø 107 mm
Tube thickness:	0,9 mm	⇒	7 mm
Weight:	52 kg		
4 concentric clamping jaws			
Motorization:	M21: 220 V		
Motorization:	M11: 110 V		

The CC120 ECO is part of the CC standard tested line. And available in a **cut-only version** to meet the needs of customers wishing to perform orbital cutting at a **low price.**”

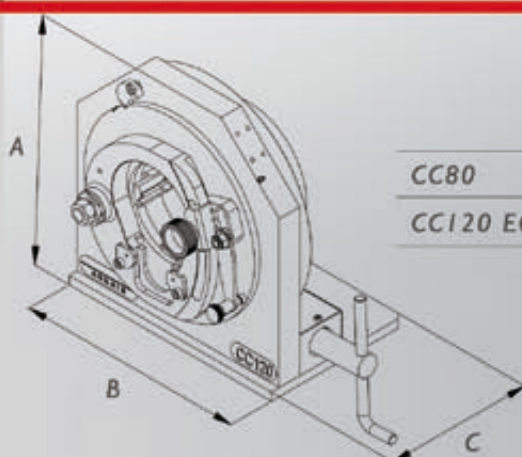

	A	B	C
CC80	262 mm	250 mm	115 mm
CC120 ECO	405 mm	380 mm	230 mm

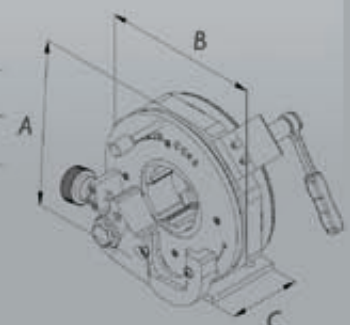



Ø5 - 121 mm

CC120

Ø16 - 170 mm

CC170

Ø59 - 225 mm

CC220

Ø140 - 330 mm

CC320

AXXAIR

“Cutting machines that easily adapt to orbital bevelling and welding”

CUTTING MACHINES

CC120

Diameter spread with basic jaws:	Ø 19 mm	⇒	Ø 121 mm
Diameter spread with additional jaws:	Ø 5 mm	⇒	Ø 107 mm
Tube thickness:	0.5 mm	⇒	15 mm
Weight:	56 kg		
4 stainless steel concentric clamping jaws			
High-speed motorisation:	FS29 - 220 V FS19 - 110 V		
Slow-speed motorisation:	FS25 - 220 V FS15 - 110 V		
Pneumatic motorisation:	MOPD		

CC170

Diameter spread with basic jaws:	Ø 56 mm	⇒	Ø 170 mm
Diameter spread with additional jaws:	Ø 16 mm	⇒	Ø 123 mm
Tube thickness:	0.8 mm	⇒	15 mm
Weight:	68 kg		
4 stainless steel concentric clamping jaws			
High-speed motorisation:	FS29 - 220 V FS19 - 110 V		
Slow-speed motorisation:	FS25 - 220 V FS15 - 110 V		
Pneumatic motorisation:	MOPD		

CC220

Diameter spread with basic jaws:	Ø 110 mm	⇒	Ø 225 mm
Diameter spread with additional jaws:	Ø 59 mm	⇒	Ø 147 mm
Tube thickness:	1 mm	⇒	15 mm
Weight:	77 kg		
6 stainless steel concentric clamping jaws			
High-speed motorisation:	FS29 - 220 V FS19 - 110 V		
Slow-speed motorisation:	FS25 - 220 V FS15 - 110 V		
Pneumatic motorisation:	MOPD		

CC320

Diameter spread with basic jaws:	Ø 216 mm	⇒	Ø 330 mm
Diameter spread with additional jaws:	Ø 140 mm	⇒	Ø 252 mm
Tube thickness:	1.5 mm	⇒	15 mm
Weight:	114 kg		
6 stainless steel concentric clamping jaws			
High-speed motorisation:	FS29 - 220 V FS19 - 110 V		
Slow-speed motorisation:	FS25 - 220 V FS15 - 110 V		
Pneumatic motorisation:	MOPD		

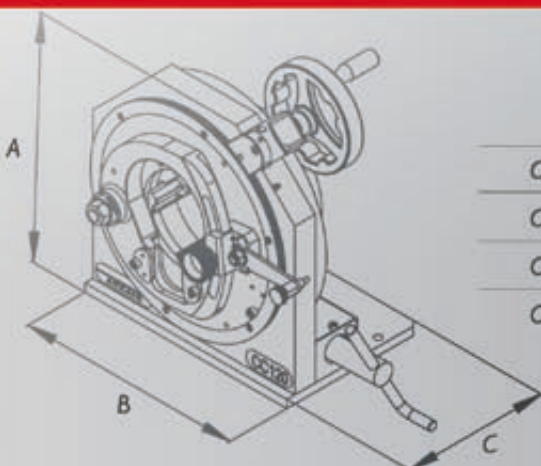

	A	B	C
CC120	405 mm	380 mm	230 mm
CC170	455 mm	430 mm	233 mm
CC220	520 mm	495 mm	230 mm
CC320	691 mm	600 mm	254 mm

Ø215 - 420 mm



Ø315 - 529 mm



Ø406,4 - 610 mm

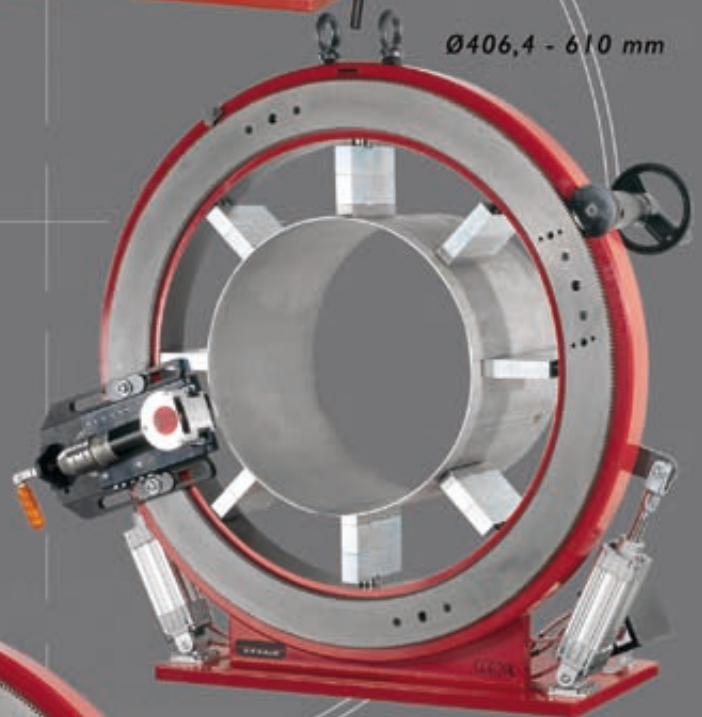

Ø457,2 - 711,2 mm



“Cutting machines that easily adapt to bevelling and welding (please inquire us for further information)”

CUTTING MACHINES

CC420

Diameter spread with basic jaws:	Ø 306 mm	⇒	Ø 420 mm
Diameter spread with additional jaws:	Ø 215 mm	⇒	Ø 320 mm
Tube thickness:	1.5 mm	⇒	15 mm
Weight:	148 kg		
6 stainless steel concentric clamping jaws			
CCPE - motor support			
High-speed motorisation:	FS29 - 220 V FS19 - 110 V		
Slow-speed motorisation:	FS25 - 220 V FS15 - 110 V		
Pneumatic motorisation:	MOPD		

CC520

Diameter spread with basic jaws:	Ø 394 mm	⇒	Ø 529 mm
Diameter spread with additional jaws:	Ø 315 mm	⇒	Ø 434 mm
Tube thickness:	1,5 mm	⇒	15 mm
Weight:	250 kg		
CCPE - motor support			
6 stainless steel concentric clamping jaws			
High-speed motorisation:	FS29 - 220 V FS19 - 110 V		
Slow-speed motorisation:	FS25 - 220 V FS15 - 110 V		
Pneumatic motorisation:	MOPD		

CC620L

4 sets of 8 jaws included for 406.4 mm 457.2 mm 508 mm 610 mm diameters			
Tube thickness:	1.5 mm	⇒	15 mm
Weight:	300 kg		
8 stainless steel concentric clamping jaws			
CCPE - motor support			
High-speed motorisation:	FS29 - 220 V FS19 - 110 V		
Slow-speed motorisation:	FS25 - 220 V FS15 - 110 V		
Pneumatic motorisation:	MOPD		

CC720L

4 sets of 8 jaws included for 457,2 mm 508 mm 610 mm 711,2 mm diameters			
Tube thickness:	1.5 mm	⇒	15 mm
Weight:	450 kg		
8 stainless steel concentric clamping jaws			
CCPE - motor support			
High-speed motorisation:	FS29 - 220 V FS19 - 110 V		
Slow-speed motorisation:	FS25 - 220 V FS15 - 110 V		
Pneumatic motorisation:	MOPD		

The CC420 - CC720L orbital cutting machines are intended for working with larger diameters. Our R&D department studies the adaptations or modifications necessary to meet customer demand on a case-by-case basis.

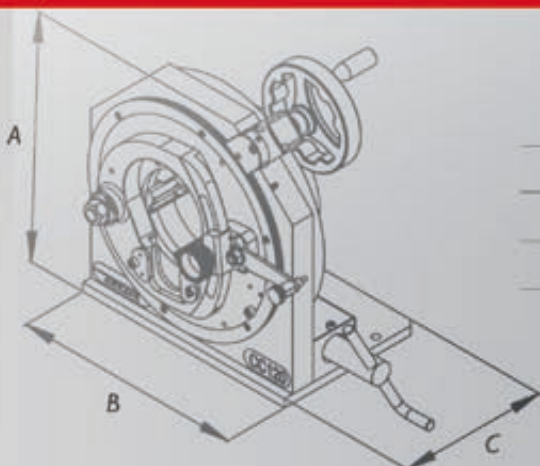

	A	B	C
CC420	791 mm	690 mm	263 mm
CC520	901 mm	790 mm	281 mm
CC620L	1085 mm	1050 mm	488 mm
CC720L	1095 mm	1116,87 mm	488 mm

Automatic electric rotation:

Electric SARAЕ type, 230 VAC, 6A max:

For CC620L and CC720L models, please inquire us

- Motor power: 90W
- Compatible for Orbital Welding
- Rotation speed adjustment: by potentiometer or through the welding power source in orbital welding.

SARAЕ-01: electric for CC120 | 170 | 220

SARAЕ-01: electric for CC320 | 420

SARAЕ-03: electric for CC520



Automatic pneumatic rotation:

- CCRAP Type, 150W
- Air power supply: 6 bars, 500 l/min
- Control by quarter-turn valve
- Speed regulation by pressure limiter
- Available for the following models: CC120 to CC520

CCRAP1: electric for CC120 | 170 | 220

CCRAP2: electric for CC320 | 420

CCRAP3: electric for CC520

620L and 720L please inquire us



Automatic pneumatic clamping:

CCSA1: electric for CC120 | 170

CCSA2: electric for CC220 | 320 | 420 | 520

CC620L and CC720L pneumatic clamping is a standard feature.



Automatic lubrication (micro pulverization):

- Tank: 0.3 liter
 - Consumption: 3 to 30 mm³
 - Frequency: from 3 pulse/sec to 1 pulse/min
 - Nozzles: 2 nozzles factory setup
 - CCLUH-A5: Power supply: 4 to 7 bars
- * available only with MOPD pneumatic motorization and in factory setup



Motorization:

FS29: Double-shafted high-speed motor | FS19: 110V

FS25: Low-speed double-shafted motor | FS15: 110V

MOPD: Pneumatic motorisation



Stands:

CCSER1: stand without ball

CCSER2: stand with balls



LS blades:

Material: Cobalt HSS
 Ø hub: Ø16 mm
 Ø driving hole: Ø 3 mm

AXXAIR references (tt=tube thickness)

LS63128: tt from 0.5 to 0.9 mm
 LS63100: tt from 0.7 to 1.5 mm
 LS6364: tt from 1 to 3 mm
 LS6872: tt from 1 to 3 mm
 LS6844: tt from 2 to 7 mm
 LS8034: tt from 5 to 12 mm
 LS8054: tt from 2 to 7 mm (large diameter tubes)
 LS8080: tt from 1 to 3 mm (large diameter tubes and squared sections) 50x50 maximum
 LS9038: tt from 5 to 15 mm



Optional titanium coating

LC type cutting and bevelling blades:

Material: Cobalt HSS
 Thickness: Ø10 mm
 Possibility of 2 bevel angles without a heel

AXXAIR references (tt=tube thickness)

LC300: 30° incline, tt from 3 to 6 mm
 LC375: 37.5° incline, tt from 3 to 6 mm

*Blade adapted to small quantities (< 5 / day), see also carbide bevelling on the following page: Bevelling machines



Lubricants:

Cutting oil:

CCLUH Material: neat cutting oil for rugged jobs
 Density: 1000 kg/m³
 Viscosity at 40°C: 164 mm²/s
 Extreme pressure 4 ball machine test: 800 daN

Cutting paste:

CCLUP Density: 1.17 kg/L
 Intended for use with CC80 and CC120 ECO



