

 **Bonfiglioli**
Riduttori

serie VF-W

Schneckengetrieben

IE2-IE3





Abschnitt	Beschreibung	Seite	Abschnitt	Beschreibung	Seite
ALLGEMEINE INFORMATIONEN		2	VF-EP / W-EP - GETRIEBE FÜR RAUE UMGEBUNGEN		176
1	Symbole und Maßeinheiten	2	31	Die vorteile der EP-Version für die Nahrungsmittelindustrie	176
2	Definitionen	3	32	Bezeichnung	178
3	Wartung	6	33	Getriebe Optionen	180
4	Antriebsauswahl	6	34	Optionen Motoren	180
5	Prüfungen	9	35	Weitere informationen über Getriebe und Getriebemotoren	181
6	Installation	9	36	Zubehör der serie EP	181
7	Lagerung	11			
8	Lieferbedingungen	11			
SCHNECKENGETRIEBE		13	ENDSCHALTER-VORRICHTUNG RVS		183
9	Konstruktive Eigenschaften	13	37	Allgemeine informationen	183
10	Bauformen	14	38	Art.-nr. für die Bestellung	184
11	Bauform	15	39	Bezeichnung	185
12	Bezeichnung	18	40	Getriebemotoren-auswahltabellen	186
13	Getriebe Optionen	20	41	Abmessungen	189
14	Schmierung	23	42	Optionen	193
15	Einbaulagen und lage des klemmenkastens	24			
16	Radialkräfte	33	ELEKTROMOTOREN		194
17	Axialkräfte	34	M1	Symbole und Maßeinheiten	194
18	Wirkungsgrad	37	M2	Einführung	195
19	Selbsthemmung	37	M3	Allgemeine Eigenschaften	197
20	Winkelspiele	39	M4	Bezeichnung für motoren	199
21	Getriebemotorenauswahltabellen	40	M5	Mechanische Eigenschaften	204
22	Getriebe auswahltabellen	67	M6	Elektrische Eigenschaften	209
23	Kombination der verhältnisse in den getrieben der serie VF/VF, VF/W, W/VF	89	M7	Drehstrombremsmotoren	217
24	Baumöglichkeiten	90	M8	Drehstrombremsmotoren mit Gleichtrombremse: typ BN_FD	218
25	Trägheitsmoment	93	M9	Drehstrombremsmotoren mit Gleichtrombremse: typ BN_AFD	222
26	Abmessungen für getriebemotoren und getrieben vorbereitet für IEC-motor	105	M10	Wechselstrombremsmotoren: typ BN_FA	226
27	Abmessungen für Getrieben mit cylindrischer antriebswelle	165	M11	Brenslüfthebel	229
28	Zubehör	169	M12	Optionen	231
29	Maschinachse	171	M13	Tabelle Motorzuordnung	243
30	Rutschkupplung	172	M14	Motorenauswahltabellen BX-MX	245
			M15	Motorenabmessungen BX-MX	246
			M16	Motorenauswahltabellen BE-ME	249
			M17	Motorenabmessungen BE-ME	253
			M18	Motorenauswahltabellen BN-M	256
			M19	Motorenabmessungen BN-M	273

Änderungen

Das Revisionsverzeichnis des Katalogs wird auf Seite 282 wiedergegeben.

Auf unserer Website www.bonfiglioli.com werden die Kataloge in ihrer letzten, überarbeiteten Version angeboten.



ALLGEMEINEINFORMATIONEN

1 SYMBOLE UND MAßEINHEITEN

Symbole	Maßeinh.	Beschreibung	Symbole	Maßeinh.	Beschreibung
$A_{N 1,2}$	[N]	Nenn-Axialbelastung	$n_{1,2}$	[min ⁻¹]	Drehzahl
f_s	–	Betriebsfaktor	$P_{1,2}$	[kW]	Leistung
f_T	–	Wärmefaktor	$P_{N 1,2}$	[kW]	Nennleistung
f_{TP}	–	Temperaturfaktor	$P_{R 1,2}$	[kW]	Benötigte Leistung
i	–	Übersetzung	$R_{C 1,2}$	[N]	Berechnete Radiallast
l	–	Relative Einschaltdauer	$R_{N 1,2}$	[N]	Zulässige Radialbelastung
J_C	[Kgm ²]	Massenträgheitsmoment der externen Massen	S	–	Sicherheitsfaktor
J_M	[Kgm ²]	Motorträgheitsmoment	t_a	[°C]	Umgebungstemperatur
J_R	[Kgm ²]	Getriebeträgheitsmoment	t_f	[min]	Betriebszeit unter Nennlast
K	–	Massenbeschleunigungsfaktor	t_r	[min]	Stillstandszeit
K_r	–	Korrekturfaktor	\square_d	–	Dynamischer Wirkungsgrad
$M_{1,2}$	[Nm]	Drehmoment	\square_s	–	Statischer Wirkungsgrad
$M_{c 1,2}$	[Nm]	Berechnetes Drehmoment			
$M_{n 1,2}$	[Nm]	Nennmoment			
$M_{r 1,2}$	[Nm]	Benötigtes Drehmoment			

¹ Werte beziehen sich auf die Antriebswelle

² Werte beziehen sich auf die Abtriebswelle



Dieses Symbol deutet auf besonders wichtige technische Informationen hin, die nicht vernachlässigt werden sollten.



Dieses Symbol gibt die Winkelbezugswerte für die Angabe der Richtung der Radialkräfte an (Stirnsicht der Welle).



Deutet auf schwerwiegende Gefahrensituationen hin, die bei Unterschätzung die Gesundheit und Sicherheit des Personals ernsthaft gefährden können.



Symbol für das Gewicht der Getriebe und der Getriebemotoren. Die in der Getriebemotoren-Tabelle genannten Werte schließen das Gewicht des vierpoligen Motors und die eingefüllte Schmierstoffmenge ein, sofern von BONFIGLIOLI RIDUTTORI vorgesehen.



Das Symbol Kennzeichnet die Seite, auf die die Information gefunden werden kann.

2 DEFINITIONEN

2.1 ABTRIEBSMOMENT

Nenn-Drehmoment M_{n2} [Nm]

Dies ist das an der Abtriebswelle übertragbare Drehmoment bei gleichförmiger Dauerbelastung bezogen auf die Antriebsdrehzahl n_1 und die entsprechende Abtriebsdrehzahl n_2 .

Das Drehmoment wird auf Grundlage eines Betriebsfaktor $f_s = 1$ berechnet.

Verlangtes Drehmoment M_{r2} [Nm]

Dies ist das von der Anwendung verlangte Drehmoment, das stets kleiner oder gleich dem Nenn-Abtriebsmoment M_{n2} des gewählten Getriebes sein muß.

Soll-Drehmoment M_{c2} [Nm]

Dies ist das bei der Wahl des Getriebes zugrundezulegende Drehmoment, wobei das übertragene Drehmoment M_{r2} und der Betriebsfaktor f_s zu berücksichtigen sind; das Soll-Drehmoment wird mit folgender Gleichung berechnet:

$$M_{c2} = M_{r2} \times f_s \leq M_{n2} \quad (1)$$

2.2 LEISTUNG

Nennleistung Antriebswelle P_{n1} [kW]

Diesen Parameter finden sie in den Getriebeauswahltabellen.

Er gibt die Leistung in kW an, welche durch das Getriebe sicher übertragen werden kann.

Die Werte beziehen sich auf die Eingangsdrehzahl n_1 und einen Betriebsfaktor von $f_s = 1$.



2.3 WIRKUNGSGRAD

Dynamischer Wirkungsgrad [η_d]

Er ist gegeben durch das Verhältnis der Abtriebsleistung P_2 zur Antriebsleistung P_1 :

$$\eta_d = \frac{P_2}{P_1} \quad (2)$$

Es soll hier insbesondere daran erinnert werden, daß die Katalogangaben für das Drehmoment M_{n2} auf Basis des dynamischen Wirkungsgrads η_d nach der Einlaufphase berechnet wurden. Nach der Einlaufzeit erreicht man auch eine Reduzierung und endlich eine Stabilisierung der Betriebstemperatur. Die Temperatur unter Last wird vom Betriebsart und von der Umwelttemperatur beeinflusst und kann Werte erreichen, die auf die Gehäuse neben der Schneckenachse gegen 80-100 °C gemessen werden, ohne die Mechanik des Getriebes zu schaden. Wenn man höheren Temperaturen gegen ca. 90-100 °C, sich erwartet, ist es notwendig das Getriebe mit Fluor-Elastomer- Dichtringen auszurüsten und in der Bestellung die Option **PV** anzugeben.

Statischer Wirkungsgrad [η_s]

Dies ist der Wirkungsgrad beim Anlaufen des Getriebes, der, obgleich er bei Zahnradgetrieben vernachlässigt werden kann, bei der Wahl von Antrieben mit Schneckengetrieben, die für den Aussetzbetrieb (z.B. Hubbetrieb) bestimmt sind, besondere Beachtung verdient.

2.4 GETRIEBEÜBERSETZUNG [i]

Die Übersetzung des Getriebes wird mit dem Buchstaben [i] bezeichnet und ist folgendermaßen Definiert:

$$i = \frac{n_1}{n_2} \quad (3)$$

2.5 TRÄGHEITSMOMENT J_r [kgm²]

Die im Katalog angegebenen Trägheitsmomente sind auf die Antriebswelle des Getriebes bezogen und daher im Falle einer direkten Verbindung schon zur Motordrehzahl in Beziehung gesetzt.



2.6 BETRIEBSFAKTOR [f_s]

Beim Betriebsfaktor handelt es sich um den Parameter, der die Betriebsbelastung, die das Getriebe aushalten muss, in einem Wert ausdrückt. Dabei berücksichtigt er, auch wenn nur mit einer unvermeidbaren Annäherung, den täglichen Einsatz, die unterschiedlichen Belastungen und eventuelle Überbelastungen, die mit der spezifischen Applikation des Getriebes verbunden sind. Der nachstehenden Grafik kann, nach der Wahl der entsprechenden Spalte mit der Angabe der täglichen Betriebsstunden der Betriebsfaktor entnommen werden, indem man die Schnittstelle zwischen der stündlichen Schaltungen und einer der Kurven K1, K2 und K3 sucht. Die mit $K_$ gekennzeichneten Kurven sind über den Beschleunigungsfaktor der Massen K an die Betriebsart gekoppelt (annähernd: gleichmäßige, mittlere oder starke Belastung), der wiederum an das Verhältnis zwischen Trägheitsmoment der angetriebenen Massen und dem des Motors gebunden ist. Unabhängig von dem so erhaltenen Betriebsfaktor, möchten wir Sie darauf hinweisen, dass es Applikationen gibt, unter denen beispielsweise auch die Hebefunktionen zu finden sind, bei denen das Nachgeben eines Getriebeorgans, das in dessen Nähe arbeitende Personal einer Verletzungsgefahr aussetzen könnte. Sollten daher Zweifel darüber bestehen, ob die entsprechende Applikation sich in diesem Bezug als kritisch erweist, bitten wir Sie sich zuvor mit unseren Technischen Kundendienst in Verbindung zu setzen.

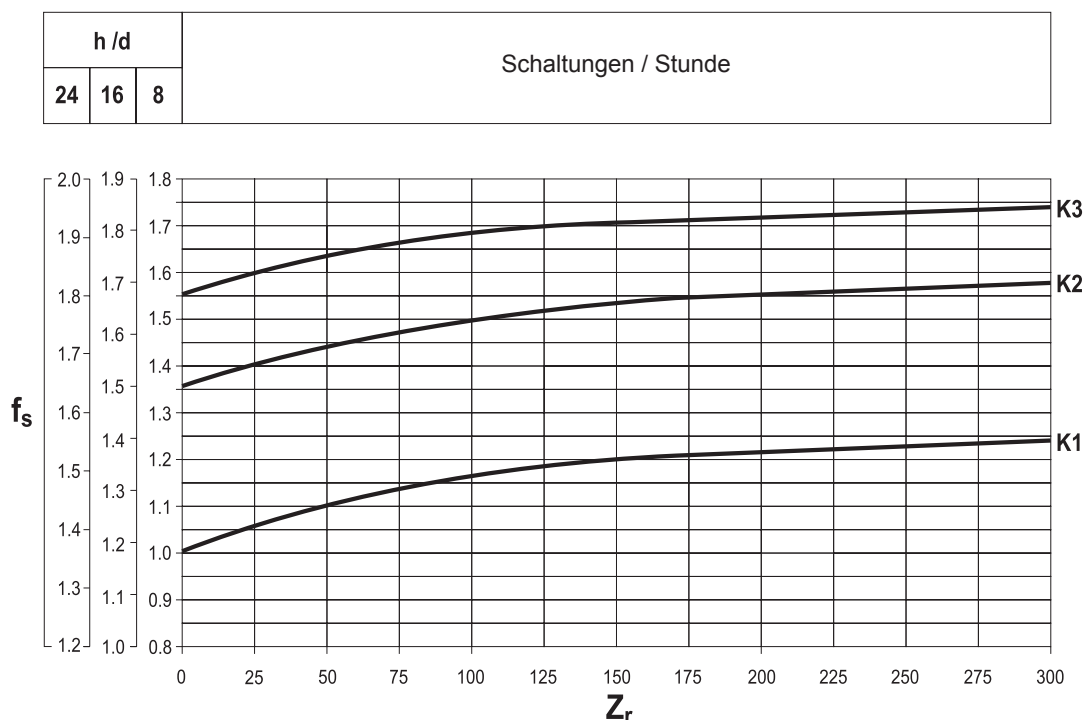

Beschleunigungsfaktor der Massen, [K]

Dieser Parameter dient der Wahl der Kurve, die sich auf die jeweilige Belastungsart bezieht. Der Wert ergibt sich aus folgender Formel:

$$K = \frac{J_c}{J_m} \quad (4)$$



$$K = \frac{J_c}{J_m} \rightarrow$$

$J_c =$ Trägheitsmoment der angetriebenen Massen, bezogen auf die Motorwelle

$J_m =$ Trägheitsmoment des Motors

$K \leq 0,25$	→ K1	Gleichmäßige Belastung
$0,25 < K \leq 3$	→ K2	Belastung mit mäßigen Stößen
$3 < K \leq 10$	→ K3	Belastung mit starken Stößen
$K > 10$	→	sich mit unseren Technischen Kundendienst in Verbindung zu setzen

3 WARTUNG

Die mit Dauerschmierung gelieferten Getriebe bedürfen periodische Ölwechsel. Bei den übrigen Getrieben wird ein erster Ölwechsel nach ca. 300 Betriebsstunden empfohlen, wobei das Innere der Gruppe sorgfältig mit einem geeigneten Reinigungsmittel zu waschen ist.

Mineralöle nicht mit Syntheseölen mischen.

Den Ölstand regelmäßig kontrollieren. Die Ölwechsel in den in der Tabelle angegebenen Fristen durchführen.

Öltemperatur [°C]	Schmierfrist [h]	
	Mineralöl	Syntheseöl
< 65	8000	25000
65 - 80	4000	15000
80 - 95	2000	12500

4 ANTRIEBSAUSWAHL

4.1 Wahl des Getriebemotors

a) Stellen Sie Betriebsfaktor f_s fest, wie früher spezifiziert.

b) Bestimmen sie die benötigte Leistung an der Getriebeeingangswelle.

$$P_{r1} = \frac{M_{r2} \times n_2}{9550 \times \eta_d} \quad [\text{kW}] \quad (5)$$

c) Unter den Getriebemotoren-Auswahltabellen die Tabelle auswählen, die folgender Leistung P_n entspricht:

$$P_n \geq P_{r1} \quad (6)$$



Wenn nicht anders angegeben, bezieht sich die im Katalog angegebene Leistung P_n der Motoren auf Dauerbetrieb S1. Bei Motoren, die unter anderen Bedingungen als S1 eingesetzt werden, muß die vorgesehene Betriebsart unter Bezug auf die CEI-Normen 2-3/IEC 34-1 bestimmt werden. Insbesondere kann man für die Betriebsarten S2 bis S8 (und für Motorbaugrößen gleich oder niedriger als 132) eine Überdimensionierung der Leistung relativ zu der für den Dauerbetrieb vorgesehenen Leistung erhalten; die zu erfüllende Bedingung ist dann:

$$P_n \geq \frac{P_{r1}}{f_m} \quad (7)$$

Der Überdimensionierungsfaktor f_m kann der Tabelle entnommen werden.

Relative Einschaltdauer

$$I = \frac{t_f}{t_f + t_r} \times 100 \quad (8)$$

t_f = Betriebszeit mit konstanter Belastung

t_r = Aussetzzeit

	BETRIEB						Rückfrage
	S2			S3*			
	Zyklusdauer [min]			Relative Einschaltdauer (I)			
	10	30	60	25%	40%	60%	
f_m	1.35	1.15	1.05	1.25	1.15	1.1	

* Die Zyklusdauer muß in jedem Fall kleiner oder gleich 10 min sein; wenn sie darüber liegt, unseren Technischen Kundendienst zu Rate ziehen.

Als nächstes wählen Sie anhand der Getriebemotoren auswahltabellen den Abschnitt mit der entsprechenden P_n und suchen die gewünschte Abtriebsdrehzahl n_2 , oder die nächstmögliche Drehzahl, zusammen mit dem Sicherheitsfaktor S , der den zutreffenden Betriebsfaktor f_s erreicht oder überschreitet.

$$S \geq f_s \quad (9)$$

Der Sicherheitsfaktor wird wie folgt berechnet:

$$S = \frac{M_{n2}}{M_2} = \frac{P_{n1}}{P_1} \quad (10)$$



Standardmäßig stehen Getriebemotorenkombinationen mit 2, 4 und 6 poligen Motoren für eine Frequenz von 50 Hz zur Verfügung. Sollten die Antriebsdrehzahlen abweichend von 2800, 1400 oder 900 min^{-1} sein, dann stützen Sie die Auslegung des Getriebes auf die Getriebeenddaten.

4.2 Wahl des Getriebes

a) Den Betriebsfaktor f_s bestimmen.

b) Bestimmen Sie das Soll-Drehmoment M_{c2} :

$$M_{c2} = M_{r2} \times f_s \quad (11)$$

c) Bestimmen Sie die erforderliche Getriebeuntersetzung.

$$i = \frac{n_1}{n_2} \quad (12)$$

d) Beziehen Sie sich auf die Getriebe Auswahl tabellen und bestimmen Sie eine Getriebegröße, dessen Nenndrehmoment bei der Antriebsdrehzahl n_1 und einer passenden Untersetzung $[i]$ folgende Bedingungen erfüllt:

$$M_{n2} \geq M_{c2} \quad (13)$$

Überprüfen Sie die Anbaumöglichkeit des gewählten Motors im Kapitel „Motor Anbaumöglichkeiten“.



5 PRÜFUNGEN

Nachdem die Auswahl des Getriebe oder Getriebemotor abgeschlossen ist, werden die folgenden Schritte empfohlen:

a) Max. Drehmoment

Im allgemeinen darf das max. Drehmoment (verstanden als momentane Lastspitze), das auf das Getriebe aufgebracht werden kann, 300 % des Nenndrehmoments M_{n2} nicht überschreiten. Sicherstellen, daß dieser Grenzwert nicht überschritten wird, und nötigenfalls die entsprechenden Vorrichtungen zur Begrenzung des Drehmoments vorsehen. Bei polumschaltbaren Drehstrommotoren muss dem Umschaltdrehmoment, das beim Umschalten von der hohen auf die niedrige Drehzahl erzeugt wird, besondere Aufmerksamkeit geschenkt werden, da es entschieden größer sein kann als das Nenn-Drehmoment. Eine einfache und kostengünstige Methode zum Senken dieses Drehmoments besteht darin, daß nur zwei Phasen des Motors während des Umschaltens gespeist werden (die Dauer der Speisung von nur 2 Phasen kann durch ein Zeitrelais gesteuert werden):

Umschaltdrehmoment	
$Mg_2 = 0.5 \times Mg_3$	
Mg_2	Umschaltdrehmoment bei Speisung von 2 Phasen
Mg_3	Umschaltdrehmoment bei Speisung von 3 Phasen

b) Radialkräfte

Sicherstellen, daß die auf die Antriebswellen und/oder Abtriebswellen wirkenden Radialkräfte innerhalb der zulässigen Katalogwerte liegen. Wenn sie höher sind, das Getriebe größer dimensionieren bzw. die Abstützung der Last verändern. Wir erinnern daran, daß alle im Katalog angegebenen Werte sich auf Kräfte beziehen, die auf die Mitte des Wellenendes wirken. Diese Tatsache muß bei der Prüfung unbedingt berücksichtigt werden und nötigenfalls muß mit Hilfe der geeigneten Formeln die zulässige Kraft beim gewünschten Abstand x bestimmt werden. Siehe hierzu die Erläuterungen zu den Radialkräften in diesem Katalog.

c) Axialkräfte

Auch die eventuell vorhandenen Axialkräfte müssen mit den im Katalog angegebenen zulässigen Werten verglichen werden. Wenn sehr hohe Axialkräfte wirken oder Axialkräfte in Kombination mit Radialkräften, bitte unseren Technischen Kundendienst zu Rate ziehen.

d) Schaltungen/Stunde

Bei anderen Betriebsarten als S1 mit einem hohen Wert für die Schaltungen/Stunde muß der Faktor Z berücksichtigt werden (er kann mit Hilfe der Angaben im Kapitel Motoren bestimmt werden), der die max. Zulässige Anzahl von Schalten für eine bestimmte Anwendung Definiert.

6 INSTALLATION

6.1 Allgemeine Eigenschaften

a) Sicherstellen, daß die Befestigung des Getriebes stabil ist, damit keine Schwingungen entstehen. Wenn es voraussichtlich zu Stößen, längerdauernden Überlasten oder zu Blockierungen kommen kann, sind entsprechende Schutzelemente wie hydraulische Kupplungen, Kupplungen, Rutschkupplungen usw. zu installieren.



- b) Beim Lackieren die bearbeiteten Flächen und die Dichtringe schützen, damit der Anstrichstoff nicht dem Kunststoff angreift und somit die Dichtigkeit der Ölabdichtungen in Frage gestellt wird.
- c) Die Organe, die mit einer Keilverbindung auf der Abtriebswelle des Getriebes befestigt werden, müssen mit einer Toleranz ISO H7 gearbeitet sein, um allzu fest blockierte Verbindungen zu vermeiden, die eventuell zu einer irreparablen Beschädigung des Getriebes während des Einbaus führen könnten. Außerdem sind beim Ein- und Ausbau dieser Organe geeignete Zugstangen und Abzieher zu verwenden, wobei die Gewindebohrung an den Köpfen der Wellen zu verwenden ist.
- d) Die Berührungsflächen müssen sauber sein und vor der Montage mit einem geeigneten Schutzmittel behandelt werden, um Oxidierung und die daraus folgende Blockierung der Teile zu verhindern.
- e) Bevor das Getriebe in Betrieb zu setzen, muß man sich vergewissern daß die das Getriebe einbauende Maschine gemäß den aktuellen Regelungen der Maschine Richtlinie 2006/42/CE ist.
- f) Vor Inbetriebnahme der Maschine sicherstellen, daß die Anordnung der Füllstandschraube der Einbaulage angemessen ist, und die Viskosität des Schmiermittels der entspricht.
- g) Bei Inbetriebnahme in Frein, muß man geeigneten Schutzgeräte vorsehen, um das Antrieb gegen Regen und direkte Sonnenstrahlung zu schützen.

6.2 Inbetriebnahme der W-Getriebe

Die Getriebeeinheiten W63, W75 und W86 werden für Transportzwecke mit einem Blindstopfen im seitlichen Deckel ausgeliefert. Vor der Inbetriebnahme muss dieser Stopfen durch einen Lüfter, ausgetauscht werden. Siehe nachfolgende Abbildung.

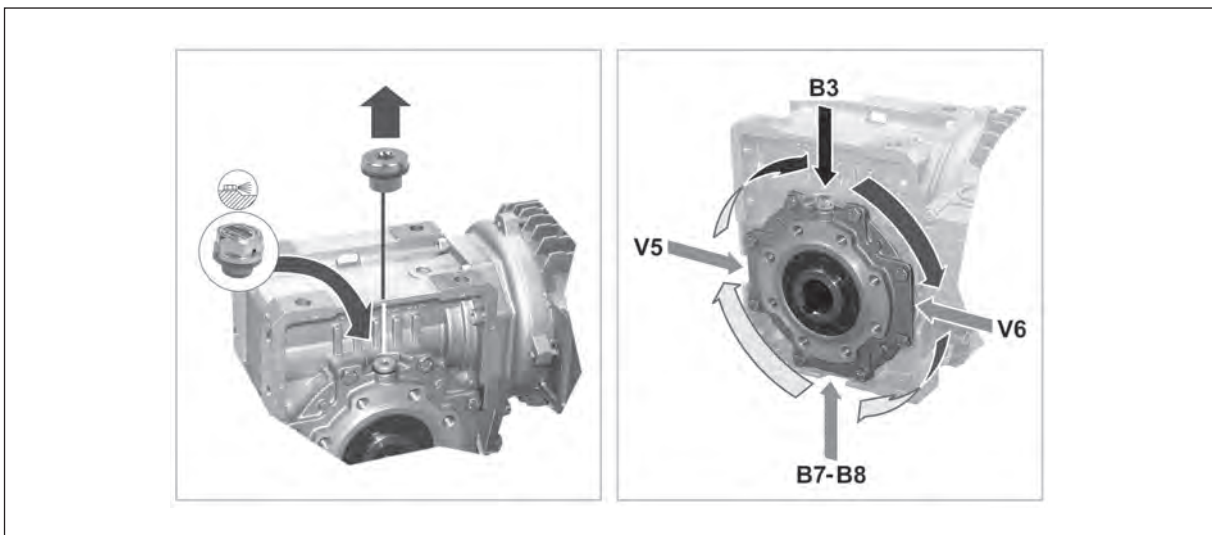

Bei der Ausrichtung B6 darf dieser Blindstopfen jedoch NICHT durch die Entlüftungsschraube ersetzt werden.



7 LAGERUNG

Die korrekte Lagerung der Antriebe erfordert folgende Vorkehrungen:

a) Die Produkte nicht im Freien lagern und nicht in Räumen, die der Witterung ausgesetzt sind, oder eine hohe Feuchtigkeit aufweisen.

b) Die Produkte nie direkt auf dem Boden, sondern auf Unterlagen aus Holz oder einem anderen Material lagern.

c) Bei anhaltenden Lager- und Haltszeiten müssen die Oberflächen für die Verbindung, wie Flansche, Wellen oder Kupplungen mit einem geeigneten Oxidationsschutzmittel behandelt werden (Mobilarma 248 oder ein äquivalentes Mittel).

Übrigens müssen die Getriebe mit nach oben gerichteter Entlüftungsschraube gelagert und mit Öl gefüllt werden.

Die Getriebe müssen vor ihrer Verwendung mit der angegebenen Menge des vorgesehenen Schmiermittels gefüllt werden.

8 LIEFERBEDINGUNGEN

Die Getriebe werden in folgendem Zustand geliefert:

a) schon bereit für die Montage in der bei Bestellung festgelegten Einbaulage;

b) nach werksinternen Spezifikationen Geprüft;

c) die Verbindungsflächen sind nicht lackiert;

d) ausgestattet mit Schrauben und Muttern für die Montage der Motoren (Version mit Adapter für IEC-Motoren);

e) alle Getriebe werden mit Kunststoffschutz auf den Wellen geliefert;

f) mit Transportriering zum Anheben (falls vorgesehen).

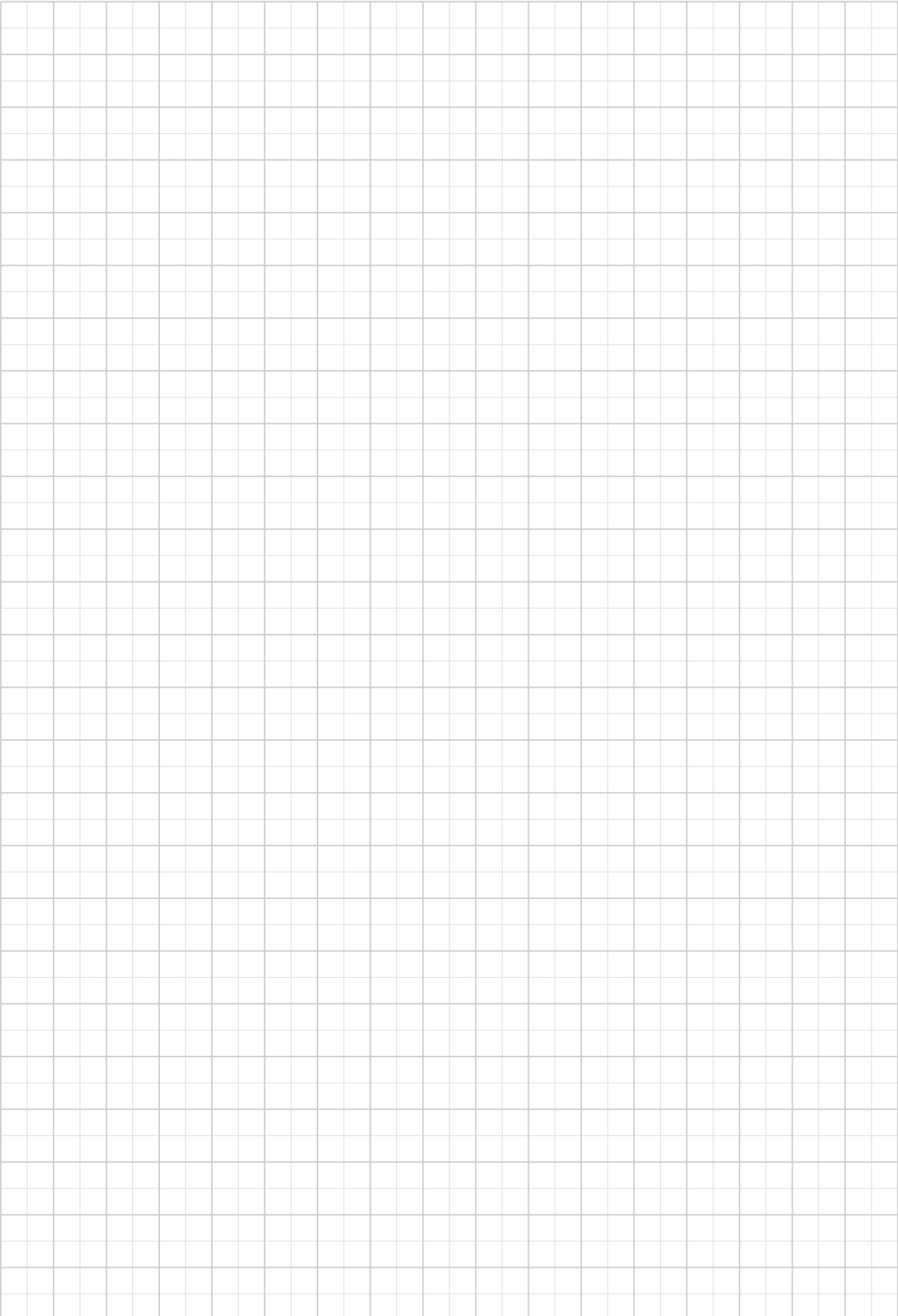

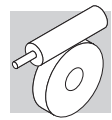

SCHNECKENGETRIEBE

9 KONSTRUKTIVE EIGENSCHAFTEN

9.1 Charakteristische Eigenschaften aller Bonfiglioli Schnecken-getriebe

- Symmetrische Hohlwellen ermöglichen eine Montage der Getriebe und der Einsteckwellen (nur als Service-Kit) auf beiden Seiten.
- Geschliffene Schneckenwellen und ihre präzise Bearbeitung ermöglichen einen hohen Wirkungsgrad und extrem niedrige Betriebsgeräusche.
- Zahlreiche Produkt-konfigurationen erlauben eine Motage über Fuß-, Flansch- oder Wellenbefestigung. Drehmoment-stützen können optional geliefert werden.
- Durch zusätzliche Optionen lassen sich die Antriebe an unterschiedliche Anwendungen anpassen.

9.2 Charakteristische Eigenschaften der VF - Serie

- Aluminium Druckguss Gehäuse für die Baugrößen: VF27, VF30, VF44 und VF49. Robuster Stahlguss für die Baugrößen: VF130 bis VF250. Wobei die letztere Gruppe mit einem Wärmehärtenden epoxyd Pulver überzogen werden.

9.3 Charakteristische Eigenschaften der W-Serie

- Monoblockgehäuse aus Aluminium
- Die kubische Form des Getriebegehäuses und die bearbeiteten Flächen aller Gehäusesseiten verleihen den Getrieben eine extreme Flexibilität bei der Montage. Durch zusätzliche Bauteile wird diese Flexibilität erweitert.
- Die Getriebe mit integrierten Motoren bauen sehr kompakt, haben geringe Gewichte und sind sehr preiswert.
- Die Wellendichtringe an der Eingangswelle der Baugrößen: W63, W75 und W86 sind aus Fluor-Elastomer und im Gehäuse integriert. Dies erhöht die Haltbarkeit und verlängerte die Lebensdauer.

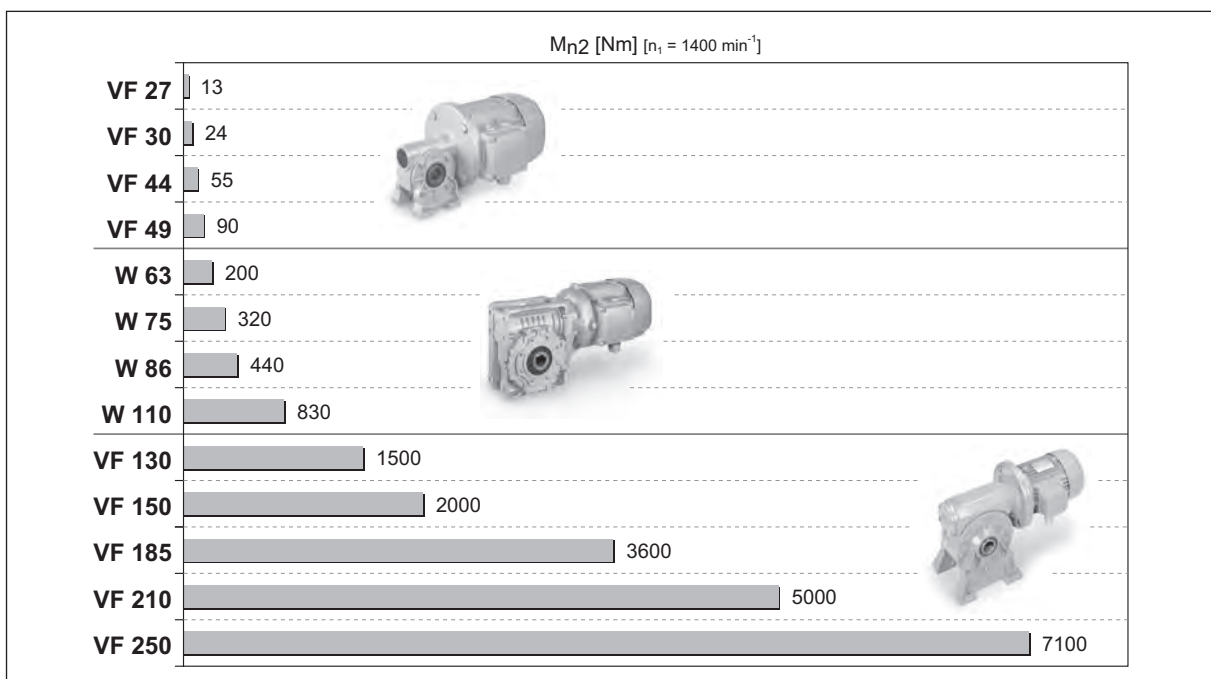



10 BAUFORMEN

VF_		W_	
	N VF 27 ... VF 250 Füßen und untenliegendet Schneckenwelle		U W 63 ... W 110 Universalgehäuse
	A VF 27 ... VF 250 Füßen und Schneckenwelle oben		
	V VF 27 ... VF 250 Füßen und senkrechter Schneckenwelle		
	F VF 27 ... VF 185 Standardflansch		UF 1 UF 2
	FA VF 44 ... VF 49 Hohem Flansch	UF W 63 ... W 110 Standardanbauflansch	
	FC VF 130 ... VF 185 Kurzem Flansch		
	FR VF 130 ... VF 185 Kurze Flansch und verstärkten Lagerni		UFC 1 UFC 2 UFCR 1 UFCR 2
	P VF 30 ... VF 250 Flansch für Drehmomentstütze	UFC W 63 ... W 110 Kurzer Anbauflansch	
	U VF 30 ... VF 49 Mit integrierten Füßen	UFCR W 75 Verkürzter Anbauflansch in Länge und Durchmesser	



11 BAUFORM

Bei Doppelschneckengetrieben werden, wenn nicht anders in der Bestellung spezifiziert, die grau hinterlegten Konfigurationen aus der nachstehenden Tabelle im Werk montiert.

	CW1	CCW1	CW2	CCW2	CW3	CCW3	CW4	CCW4
U								
UF_ UFC_ UFR1_								
N								
A								
V								
F1 FA1 FC1 FR1								
F2 FA2 FC2 FR2								
P1								
P2								

Deckel für Aufsteckmontage



Bei der Ausführung HS (Getriebe) sind alle abgebildeten Montageausführungen möglich.
Bei der Ausführung P (IEC) können bestimmte Montageausführungen nur durch Verwendung von IEC-Flanschen (B5 oder B14) erreicht werden, die gleich groß oder kleiner als die in den folgende Tabelle angegebenen sind.

		CW1 CCW1	CW2 CCW2	CW3	CCW3	CW4 CCW4
VF/VF30/44	A, N, V, P1	63B14	63B14	63B14	63B14	63B14
	F-FA					
VF/VF30/49	A, N, V, P1	63B14	63B14	63B14	63B14	63B14
	F-FA					
VF/W30/63	U	63B5-63B14	63B5-63B14	63B5-63B14	63B5-63B14	63B5-63B14
	UF-UFC					
VF/W44/75	U	71B5-71B14	71B5-71B14	71B5-71B14	71B5-71B14	71B5-71B14
	UF-UFC-UFCR					
VF/W44/86	U	71B5-71B14	71B5-71B14	71B5-71B14	71B5-71B14	71B5-71B14
	UF-UFC					
VF/W49/110	U	80B5-80B14	80B5-80B14	80B5-80B14	80B5-80B14	80B5-80B14
	UF-UFC					
W/VF63/130	N	71B5-90B14	90B5-90B14	71B5-90B14	71B5-90B14	71B5-90B14
	A	90B5-90B14	71B5-90B14	90B5-90B14	90B5-90B14	90B5-90B14
	V		90B5-90B14			—
	F1	90B5-90B14	71B5-90B14	90B5-90B14	71B5-90B14	90B5-90B14
	FC1-FR1					
	P1				90B5-90B14	
	F2	90B5-90B14	71B5-90B14	71B5-90B14	90B5-90B14	90B5-90B14
	FC2-FR2			90B5-90B14		
P2			90B5-90B14			
W/VF86/150	N	112B5-112B14	112B5-112B14	71B5-112B14	71B5-112B14	71B5-112B14
	A	112B5-112B14	90B5-112B14	112B5-112B14	112B5-112B14	112B5-112B14
	V	112B5-90B14	112B5-90B14			71B5-112B14
	F1	112B5-112B14	71B5-90B14	112B5-112B14	71B5-90B14	112B5-112B14
	FC1-FR1		90B5-112B14		112B5-112B14	
	P1					
	F2	112B5-112B14	71B5-90B14	71B5-90B14	112B5-112B14	112B5-112B14
	FC2-FR2		90B5-112B14	112B5-112B14		
P2						
W/VF86/185	N	112B5-112B14	112B5-112B14	90B5-112B14	90B5-112B14	90B5-112B14
	A	90B5-112B14	112B5-112B14	112B5-112B14	112B5-112B14	112B5-112B14
	V	112B5-90B14				90B5-112B14
	F1	112B5-112B14	90B5-112B14	112B5-112B14	90B5-112B14	112B5-112B14
	FC1-FR1				112B5-112B14	
	P1				112B5-112B14	
	F2	112B5-112B14	90B5-112B14	90B5-112B14	112B5-112B14	112B5-112B14
	FC2-FR2			112B5-112B14		
P2			112B5-112B14			
VF/VF130/210	N	#	132B5	#	#	#
	A	132B5	#	132B5	132B5	132B5
	V					
	P					
VF/VF130/250	N	#	132B5	#	#	#
	A	132B5	#	132B5	132B5	132B5
	V		132B5			
	P		#			

Bitte nehmen Sie mit unserem Technischen Verkaufsdienst Kontakt auf



11.1 Ausrichtung des Klemmenkastens

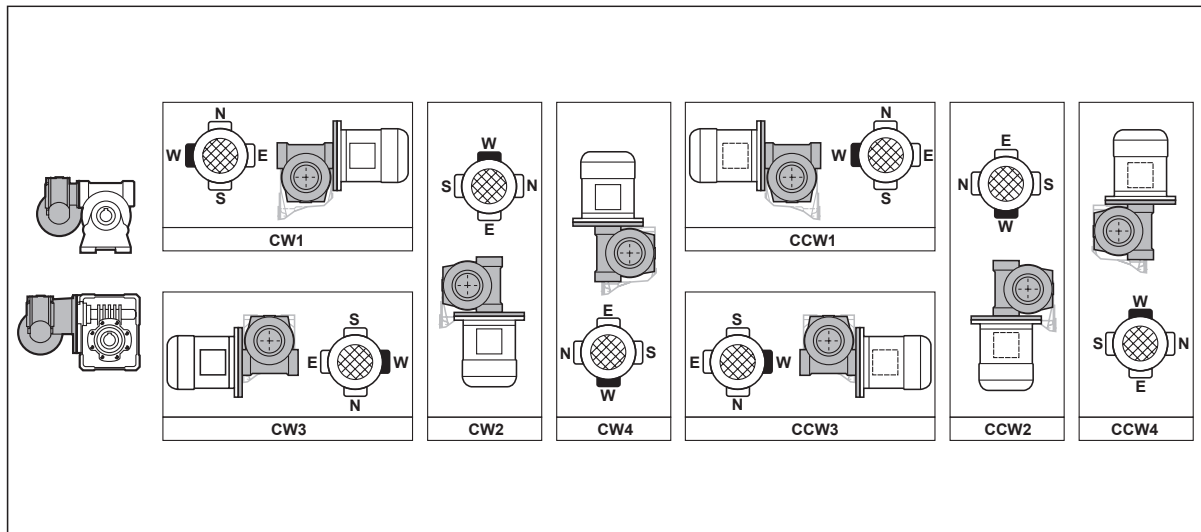



12 BEZEICHNUNG

GETRIEBE

W 63 L1 UF1 — 24 S2 — B3

OPTIONEN

BAUFORM

VF/VF, VF/W, W/VF	CW (1, 2, 3, 4) CCW (1, 2, 3, 4)
-------------------	---

EINBAULAGEN

VF 27...VF 49 VFR 44, VFR 49	B3
W, WR VF 130...VF 250 VFR 130...VFR 250	B3 (default), B6, B7, B8, V5, V6
VF/VF VF/W W/VF	B3 (default), B6, B7, B8, V5, V6

MOTOR BAUFORM

B5	(VF 30...VF 250, VFR 49...VFR 250, W, WR)
B14	(VF 30...VF 49, W)

BEZEICHNUNG DER ANTRIEBSSEITE

	VF	VFR	W	WR	VF/VF	VF/W	W/VF
P(IEC)	 P27 (VF 27 only), P56...P225	 P63, P80...P160	 P71...P132	 P63...P112	 P56, P63, P90...P132	 P56...P80	 P71...P112
S_		 S44 (VFR 44 only)	 S1...S3				 S1...S3
HS							

ÜBERSETZUNG

ABTRIEBSWELLEDURCHMESSER

W 75 VF/W 44/75	D30 (default), D28 (Option)
--------------------	------------------------------------

BAUFORM

RUTSCHKUPPLUNG

VF, VFR W, WR	L1, L2	VF/VF	LF
------------------	---------------	-------	-----------

GETRIEBEBAUGRÖSSE

VF	27, 30, 44, 49, 130, 150, 185, 210, 250	VF/VF	30/44, 30/49, 130/210, 130/250
VFR	44, 49, 130, 150, 185, 210, 250	VF/W	30/63, 44/75, 44/86, 49/110
W, WR	63, 75, 86, 110	W/VF	63/130, 86/150, 86/185

GETRIEBE TYP

VF, W	Schneckengetriebe
VFR, WR	Schneckengetriebe mit Vorstufe
VF/VF, VF/W, W/VF	Doppelschneckengetriebe

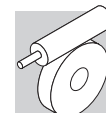

MOTOR

BREMSE

BN 63A 4 230/400-50 IP54 CLF W FD 3.5 R SB 220 SA

OPTIONEN

BREMSVERSORGUNG

GLEICHRICHTERTYP
AC/DC
NB, SB, NBR, SBR

BREMSHANDLÜFTUNG
R, RM

BREMSMOMENT

BREMSENTYP
FD, AFD (G.S. Bremse)
FA (W.S. Bremse)

KLEMMKASTENLAGE
W (default), **N, E, S**

BAUFORM
— (Kompaktmotor)
B5, B14 (IEC - Motor)

ISOLIERUNGSKLASSE
CL F Standard
CL H Option

SCHUTZART
IP55 Standard (IP54 - Bremssmotor)

SPANNUNG - FREQUENZ

POLZAHL
2, 4, 6, 2/4, 2/6, 2/8, 2/12, 4/6, 4/8

MOTOR-BAUGRÖSSE
1SC ... 3LB (Kompaktmotor)
56A ... 180L (IEC - Motor) BN 27, BN 44 (Spezialmotoren)

MOTORTYP

MX = Dreiphasen Kompaktmotor,
Klasse IE3

BX = Dreiphasen IEC Motor,
Klasse IE3

MOTORTYP

ME = Dreiphasen Kompaktmotor,
Klasse IE2

BE = Dreiphasen IEC Motor,
Klasse IE2

MOTORTYP

M = Dreiphasen Kompaktmotor

BN = Dreiphasen IEC Motor



13 GETRIEBE OPTIONEN

SO

Die Getriebetypen VF 30 ... VF 49, W 63 ... W 86, das normalerweise sind mit Schmiermittel geliefert, werden ohne Öl geliefert.

LO

Die normalerweise ohne Schmiermittel gelieferten Getriebe vom VF 130...VF 250 und W 110, die gewöhnlich ohne Schmiermittel geliefert werden, in Übereinstimmung mit der Einbaulage gefüllt mit dem normalerweise von BONFIGLIOLI RIDUTTORI verwendeten synthetischen Schmierstoff. Die Anwendbarkeit der Option LO wird in der folgenden Tabelle näher erläutert.

	LO					
	Einbaulagen					
	B3	B6	B7	B8	V5	V6
W 110 U-UF-UFC	X	X	X	X	●	●
VF 130 A-N-P-F-FC	X	X	X	X	●	●
VF 130 V	●	X	X	●	X	X
VF 130 FR	X	●	●	X	●	●
VF 150 A-N-P-F-FC	X	X	X	X	●	●
VF 150 V	●	X	X	●	X	X
VF 150 FR	X	●	●	X	●	●
VF 185 A-N-P-F-FC	X	X	X	X	●	●
VF 185 V	●	X	X	●	X	X
VF 185 FR	X	●	●	X	●	●
VF 210 A-N-P	X	●	●	X	●	●
VF 210 V	●	●	●	●	X	X
VF 250 A-N-P	X	●	●	X	●	●
VF 250 V	●	●	●	●	X	X

RB

Zweites Wellenende gegenüber von Eingangswelle (außer VF 27).

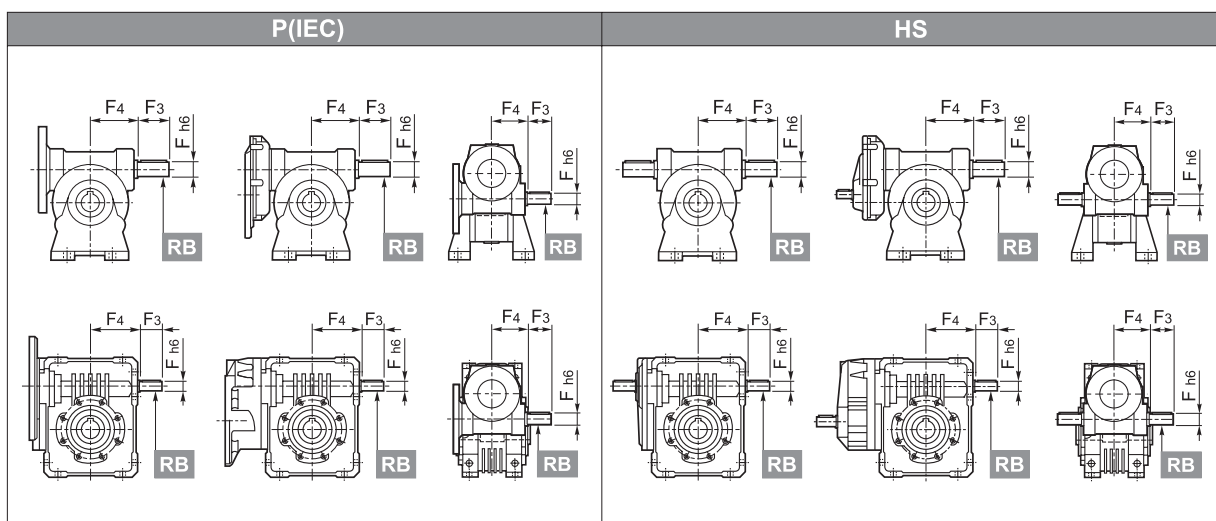



RBO

Zusätzliches Schneckenwellenende am 2. Getriebe (nur bei Doppelschneckengetrieben).

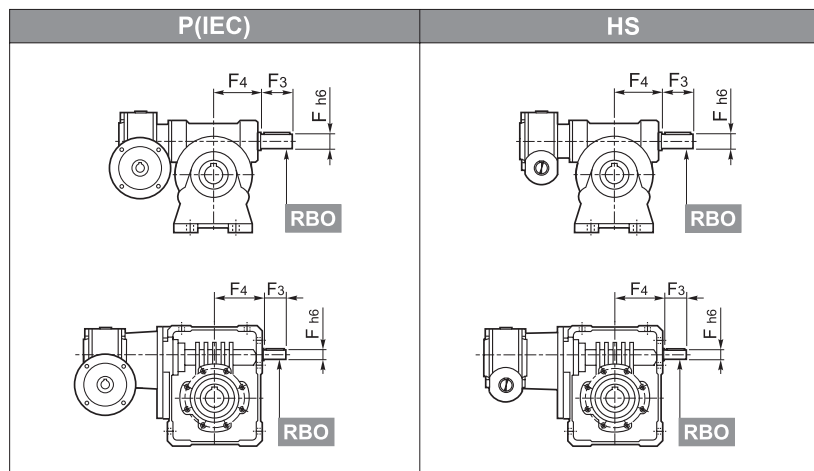

Abmessungen für frei hervorstehende welle (optionen RB und RBO)							
		F	F1	F2	F3	F4	V
VF	30	9	10.2	3	20	50	—
VFR	44	11	12.5	4	30	56	—
VF/VF	49	16	18	5	40	65	M6
W	63	18	20.5	6	40	74	M6
WR	75	19	21.5	6	40	88.5	M6
VF/W	86	25	28	8	50	101.5	M8
	110	25	28	8	60	127.5	M8
VF	130	30	33	8	60	160	M8
VFR	150	35	38	10	65	185	M8
W/VF	185	40	43	12	70	214.5	M8
	210	48	51.5	14	82	185	M16x40
	250	55	59	16	82	228	M16x40

Für VF 210-250, in den Baumodellen **A** und **P**, wird in der Regel ein Kühlungsgebläse montiert; mit der Option **RB** kann dieses nicht montiert werden

VV

Wellendichtringe aus Fluor-Elastomer auf der Antriebswelle. Lieferbar für W110 und für die VF-Reihe. Ausschließlich VF 30 nach Ausführung RB und/oder HS.

PV

Alle Wellendichtringen aus Fluor-Elastomer. Ausschließlich VF 30 nach Ausführung RB und/oder HS .

KA

Durch mit VF_A austauschbarem Satz - Abstellfüße komplettiert.

KV

Durch mit VF_V austauschbarem Satz - Abstellfüße komplettiert (W mit Option RB ausgeschlos).

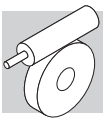

AO

Abtriebswelle auf die Gegenseite als Standard (VF 27).

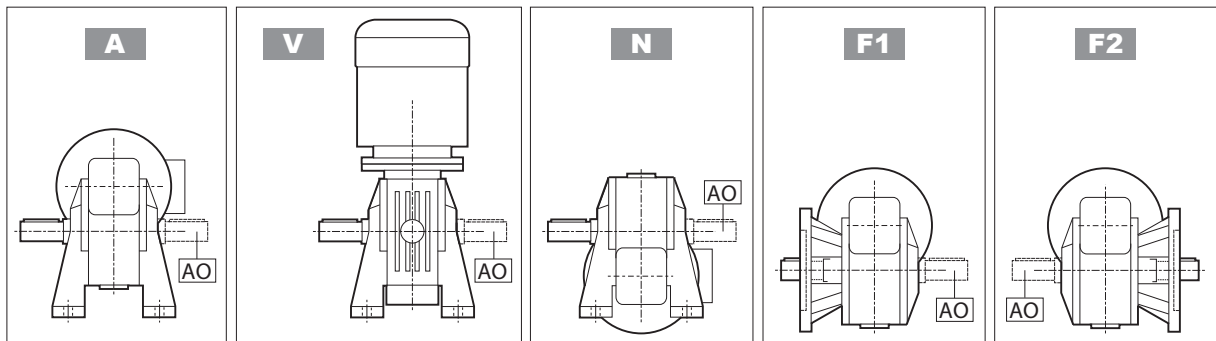

OBERFLÄCHENSCHUTZ

Wenn keine besondere Korrosionsschutzklasse gefordert ist, ist die lackierte Oberfläche des Getriebes mindestens mit einem Schutz gegen Korrosion der Klasse C2 nach UNI EN ISO 12944-2 geschützt. Für eine bessere Witterungsbeständigkeit können die Getriebe, durch eine Lackierung des ganzen Getriebes, mit einem Oberflächenschutz der Klassen **C3** und **C4** geliefert werden.

OBERFLÄCHENSCHUTZ	Typische Umgebungen	Maximale Oberflächen-temperatu	Korrosionsschutzklasse nach UNI EN ISO 12944-2
C3	Stadt- und Industrieumgebung mit bis zu 100% relativer Luftfeuchtigkeit (mittlere Luftverschmutzung)	120°C	C3
C4	Industrie- und Küstengebiete und Chemieanlagen mit bis zu 100% relativer Luftfeuchtigkeit (hohe Luftverschmutzung)	120°C	C4

Getriebe mit einem optionalen Korrosionsschutz der Klassen **C3** oder **C4** sind in einer Auswahl von Farben verfügbar. Wenn keine spezielle Farbe gefordert ist, (siehe Option „Lackierung“) ist der Decklack in RAL 7042. Unsere Getriebe können auch mit Oberflächenschutz der Klasse **C5** nach UNI EN ISO 12944-2 versehen werden. Für weitere technische Informationen wenden Sie bitte an unseren Technischen Service.

LACKIERUNG

Getriebe mit Oberflächenschutz der Klasse C3 oder C4, sind in den, in der folgenden Liste aufgelisteten Farben, verfügbar.

LACKIERUNG	Farbe	RAL Nummer
RAL7042*	Traffic Grey A	7042
RAL5010	Gentian Blue	5010
RAL9005	Jet Black	9005
RAL9006	White Aluminium	9006
RAL9010	Pure White	9010

* Die Getriebe werden in dieser Standardfarbe geliefert, wenn keine andere Farbe angegeben ist.



Hinweis – Die Option “Lackierung” kann nur im Zusammenhang mit dem Oberflächenschutz spezifiziert werden.

NACHWEISE

AC - Konformitätsbescheinigung Dokument mit dessen Ausstellung die Konformität des Produkts mit dem Auftrag, und dessen Konstruktion in Konformität mit den vom Qualitätsmanagementsystem von Bonfiglioli Riduttori vorgesehenen Standardfertigungs- und -kontrollverfahren bescheinigt wird.

CC – Prüfzeugnis

Die Bestellung führt zur Durchführung von Kontrollen der Konformität mit dem Auftrag, allgemeinen Sichtkontrollen und instrumentalen Prüfungen der Passmaße. Des Weiteren werden allgemeine Betriebskontrollen bei Leerlauf sowie Prüfungen der Funktionalität der Dichtungen bei Stillstand und während des Betriebs durchgeführt. Die Prüfung wird anhand einer Stichprobe des Versandloses durchgeführt.

Optionen Motoren

Detaillierte Informationen entnehmen Sie bitte dem Kapitel “Elektromotoren”.

14 SCHMIERUNG

14.1 Schmierung der Getriebe der serie W und VF

Die Getriebegrößen VF 27 ... VF 49, W 63 ... W 86 sind bei der Lieferung ab Werk bzw. ab offiziellem Verkaufsnetz mit einer synthetischen “Long-Life” -Dauerschmierung versehen. Auf Anfrage können die oben benannten Einheiten auch ohne Öl geliefert werden. Hier muss bei der Bestellung die Option **SO** angegeben werden. Die Anwendbarkeit der Option wird im Kapitel „GETRIEBE OPTIONEN“ näher erläutert.

Falls nicht anders spezifiziert werden die Getriebe VF 130 ... VF 250 und W 110 grundsätzlich ohne Ölfüllung ausgeliefert. Vor der Inbetriebnahme muss das Getriebe kundenseitig mit der richtigen Ölfüllmenge befüllt werden. Sollten Sie diese Getriebe mit der Option **LO** bestellen, werden die Einheiten direkt vom Werk aus mit synthetischem Öl, gemäß der spezifizierten Einbaulage, befüllt. Die Anwendbarkeit der Option wird im Kapitel „GETRIEBE OPTIONEN“ näher erläutert.

Doppelschneckengetriebe Typ VF/VF, VF/W und W/VF bestehen aus zwei separaten Einheiten mit eigenen Ölfüllungen.

Hinsichtlich der Bezugsübersichten mit der Einbaulage der Serviceschrauben/Stopfen und den Angaben zu den Schmierstoffmengen bitte die Betriebs- und Wartungsanleitung einsehen (auf www.bonfiglioli.com verfügbar).









Die mit Lebensdauerschmierung gelieferten Getriebe sind mit synthetischem Öl auf Polyglykolbasis befüllt. Sollte das Öl nicht durch äußere Einwirkungen verunreinigt werden, benötigt das Getriebe über die gesamte Lebensdauer keinen Ölwechsel. Die Getriebe dürfen bei einer Umgebungstemperatur von -20°C bis +40°C betrieben werden. Allerdings darf ein Start unter Last bei -20°C bis -10°C erst nach stufenweiser und gleichmäßiger Vorwärmung erfolgen.

Anderfalls muss das Anfahren ohne Last erfolgen. Die Last darf erst zugeschaltet werden, wenn die Getriebeeinheit eine Temperatur von mindestens -10° oder höher erreicht hat.

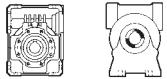

14.2 Ölsorte

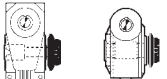
Bonfiglioli weist noch darauf hin, dass im Fall einer Wahl eines Schmiermittels, das nicht vom empfohlenen Typ SHELL ist, dieses in seiner Zusammensetzung im Hinblick auf die synthetische Natur und die Viskosität gleichwertig und darüber hinaus mit den entsprechenden schaumhemmenden Zusatzstoffen ausgestattet sein muss. Für die Tabelle Schmierstoffempfehlung / erlaubt im Wartungshandbuch (auf www.bonfiglioli.com verfügbar) beziehen.

			Einbaulagen	
			B3 - B6 - B7 - B8 - V5	V6
	Planten- vorgelege	WR 63...WR 86	 OMALA S4 WE 320	 GADUS S5 V142W 00
		VFR 44...VFR 250 WR 110	 OMALA S4 WE 320	
	Schnecken- getriebe	W 63...W 110 VF 44...VF 250	 OMALA S4 WE 320	
	Getriebe mit Drehzahl- begrenzer	W 63...W 110 VF 44...VF 49	 OMALA S4 WE 460	

15 EINBAULAGEN UND LAGE DES KLEMMENKASTENS

Die Angaben zur Lage des Klemmenkastens beziehen sich auf das von der Lüfterseite her betrachtete Getriebe. Die Standardorientierung ist schwarz hervorgehoben (W).

Die in der Tabelle dargestellten Positionen auf der Klemmenleiste sind nicht für VFR 44 gültig. Für die Zuordnung und die Identifizierung der Bauform ist Bezug auf die Seiten 19 und 110-111 zu nehmen.

Winkellage des Handlüfterhebels.

Bei Bremsmotoren wird der Handlüfterhebel (auf Anfrage) standardmäßig auf 90° gegenüber des Klemmkastens (AB-Anordnung) geliefert; wird eine andere Anordnung verlangt, muß dies bei der Bestellung durch das geeignete Option angegeben werden.

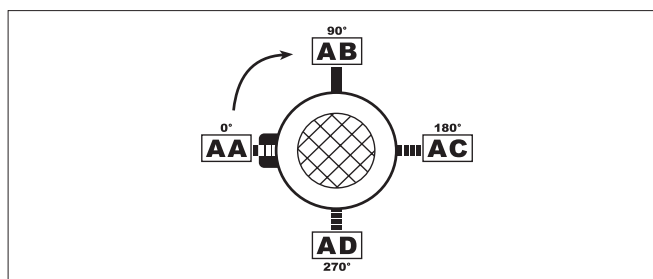

Auf den nachfolgenden Seiten sind die Einbaulagen der Getriebetypen VF und W beschrieben.

Für die kombinierten Getriebe der Typen VF/VF, VF/W und W/VF beziehen sich die Einbaulagen auf das zweite Getriebe (Maschinenseite); hinsichtlich des ersten Getriebes (Antriebsseite) ist auf das Kapitel "Ausführung des Einbaus" Bezug zu nehmen.



VF 27 _ ... VF 49 _ **VFR 44 _ , VFR 49 _**

				_HS	_S - _P (IEC)		
A	B3	B7	V5				← VF
	B6	B8	V6				← VFR
N	B3	B7	V5				← VF
	B6	B8	V6				← VFR
V	B3	B7	V5				← VF
	B6	B8	V6				← VFR
P	B3	B7	V5				← VF
	B6	B8	V6				← VFR
F	B3	B7	V5				← VF
	B6	B8	V6				← VFR
U	B3	B7	V5				← VF
	B6	B8	V6				← VFR

Grundeinbaulage.

Die Getriebe sind ausschließlich in der Grundeinbaulage (B3) beschil-dert; sie können aber auch in abge-leiteten Einbaulagen (B6, B7, B8, V5, V6) installiert werden. Nach der Installation ist es nicht möglich, die Einbaulage zu ändern.



W 63 U ... W 110 U

WR 63 U ... WR 110 U

_HS

_S - _P (IEC)

B3

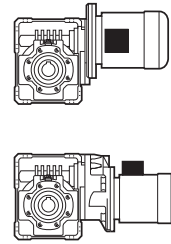
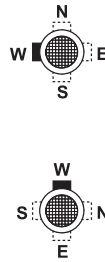
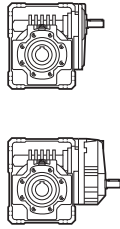
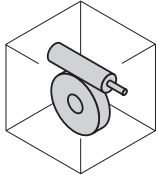

B6

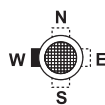
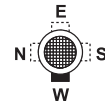
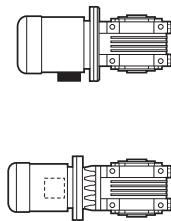
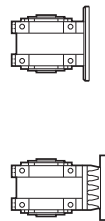
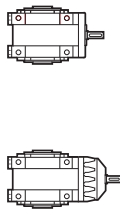
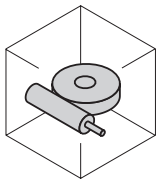

B7

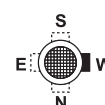
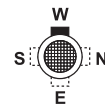
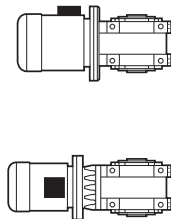
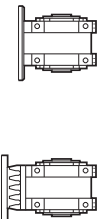
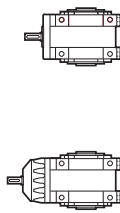
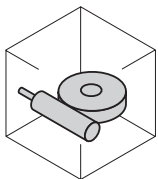

B8

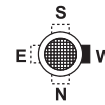
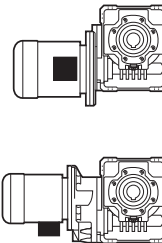
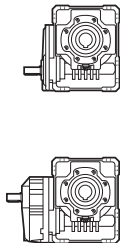
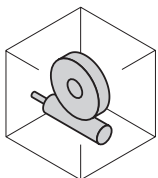

V5

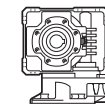
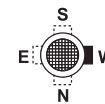
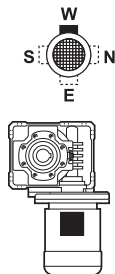
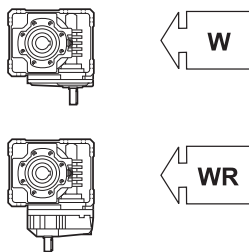
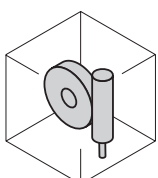

V6

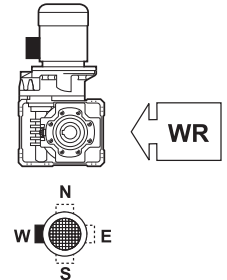
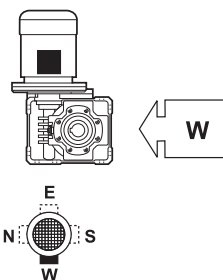
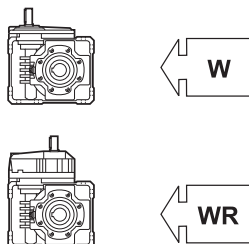
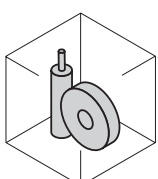

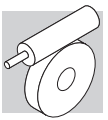

W 63 UF/UFC ... W 110 UF/UFC WR 63 UF/UFC ... WR 110 UF/UFC

_HS

_S - _P (IEC)

B3

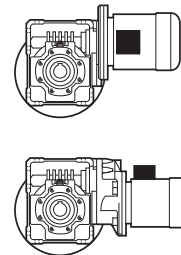
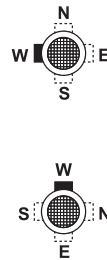
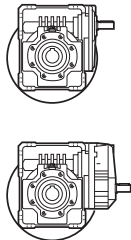
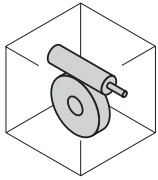

B6

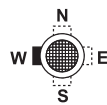
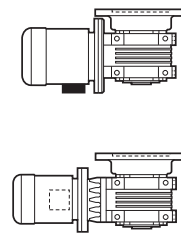
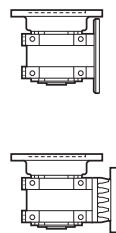
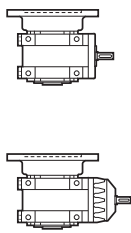
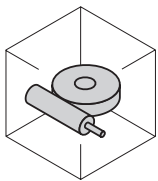

B7

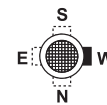
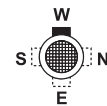
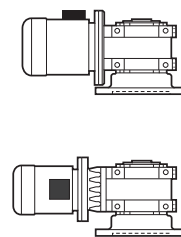
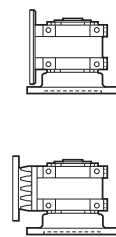
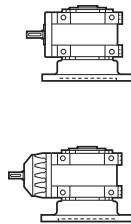
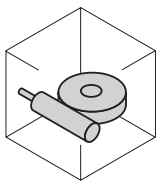

B8

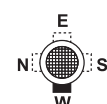
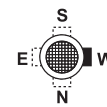
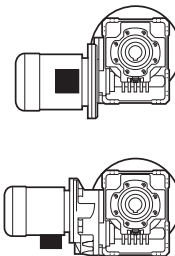
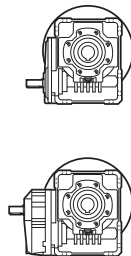
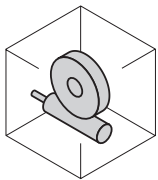

V5

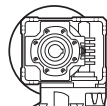
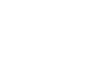
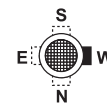
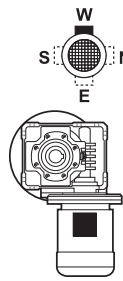
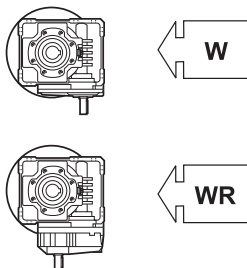
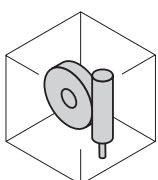

V6

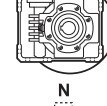
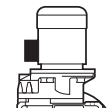
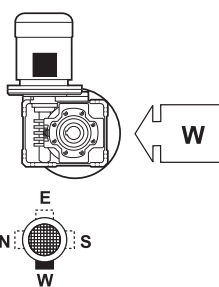
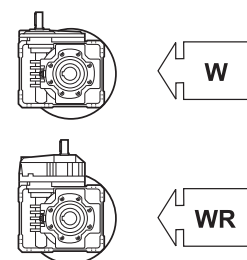
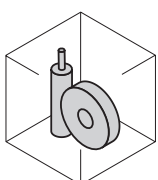



VF 130 A ... VF 250 A

VFR 130 A ... VFR 250 A

_HS

_P (IEC)

B3

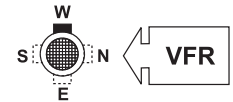
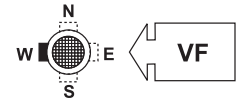
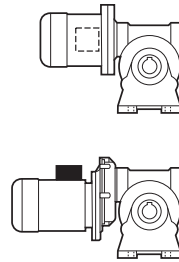
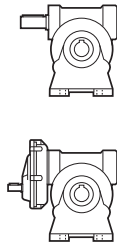
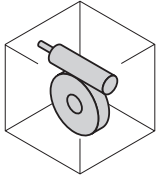

B6

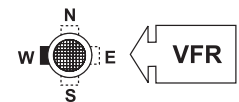
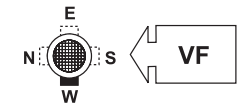
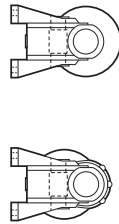
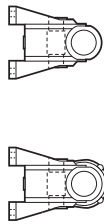
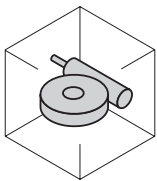

B7

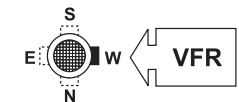
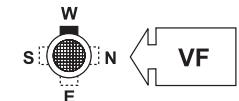
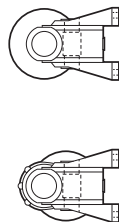
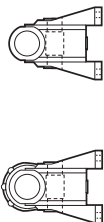
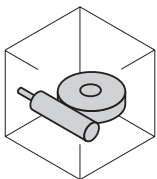

B8

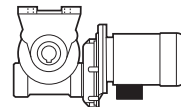
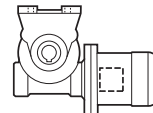
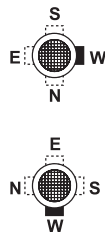
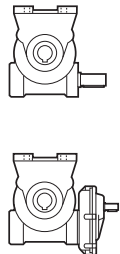
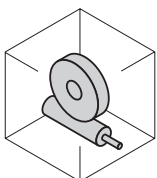

V5

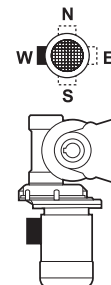
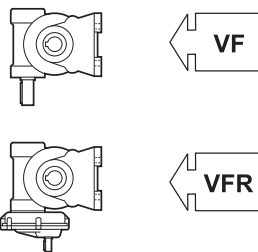
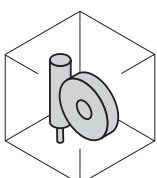

V6

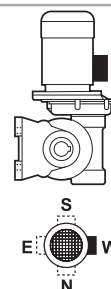
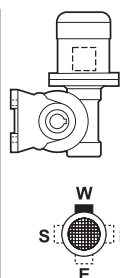
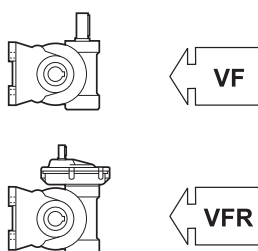
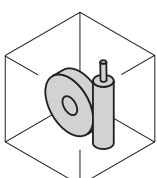

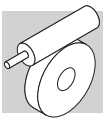

VF 130 N ... VF 250 N VFR 130 N ... VFR 250 N

	_HS	_P (IEC)
B3		
B6		
B7		
B8		
V5		
V6		



VF 130 V ... VF 250 V

VFR 130 V ... VFR 250 V

_HS

_P (IEC)

B3

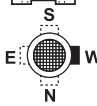
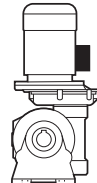
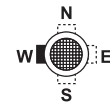
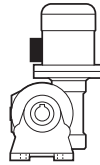
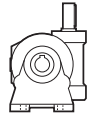
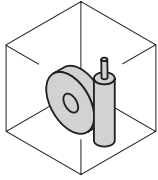

B6

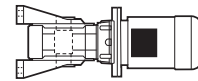
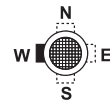
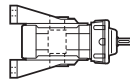
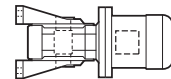
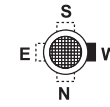
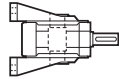
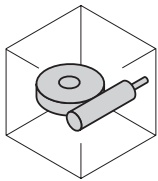

B7

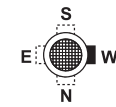
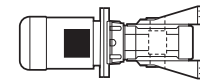
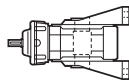
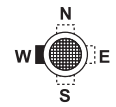
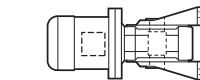
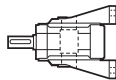
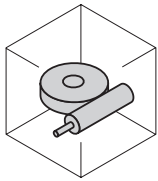

B8

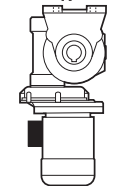
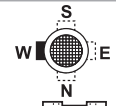
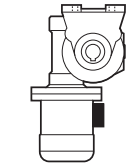
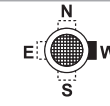
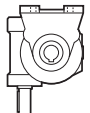
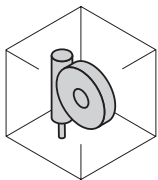

V5

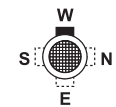
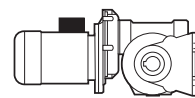
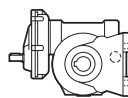
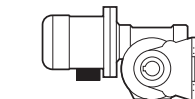
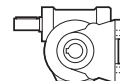
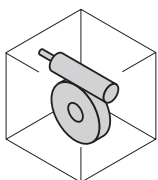

V6

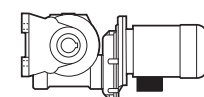
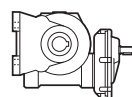
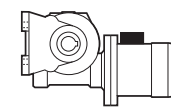
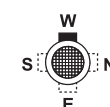
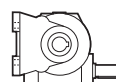
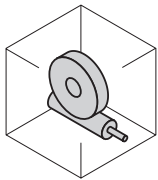



VF 130 P ... VF 250 P VFR 130 P ... VFR 250 P

_HS

_P (IEC)

B3

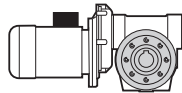
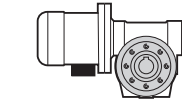
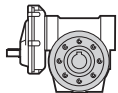
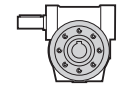
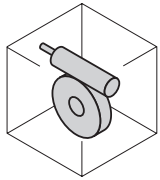

B6

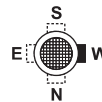
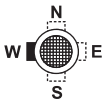
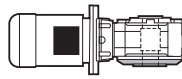
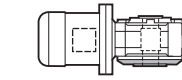
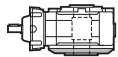
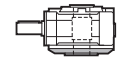
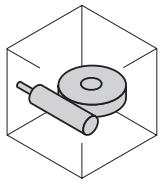

B7

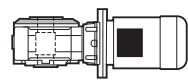
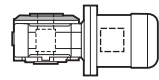
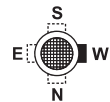
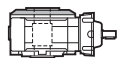
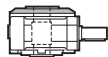
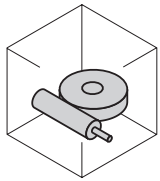

B8

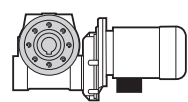
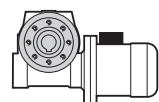
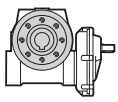
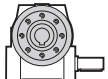
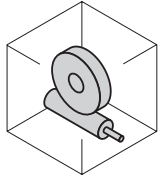

V5

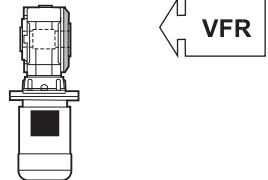
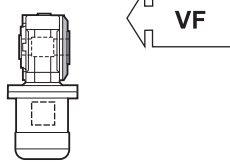
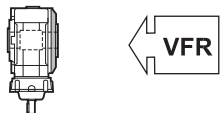
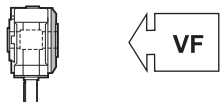
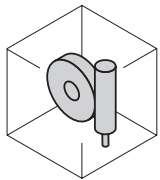

V6

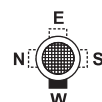
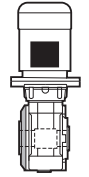
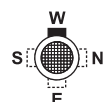
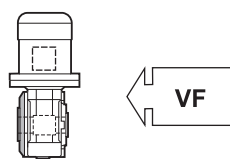
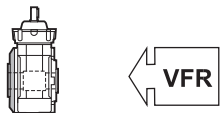
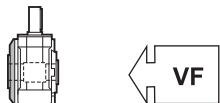
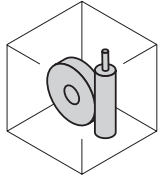



VF 130 F ... VF 250 F

VFR 130 F ... VFR 250 F

_HS

_P (IEC)

B3

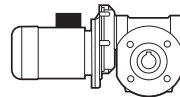
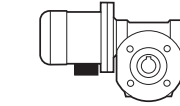
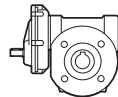
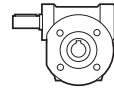
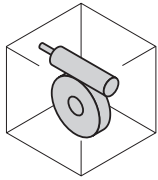

B6

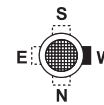
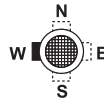
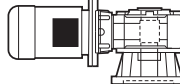
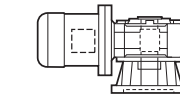
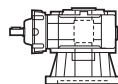
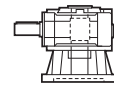
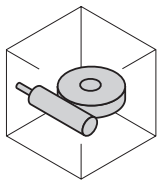

B7

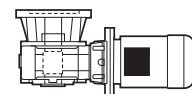
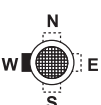
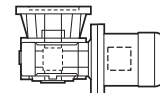
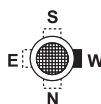
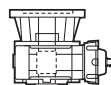
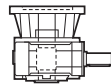
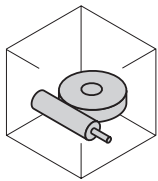

B8

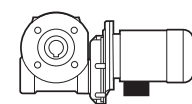
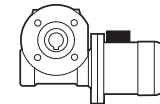
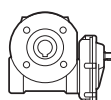
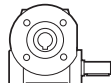
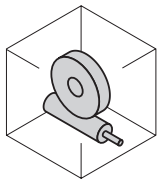

V5

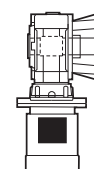
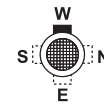
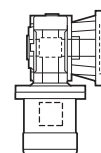
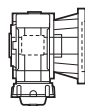
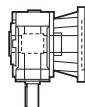
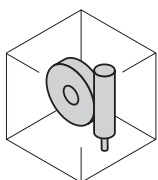

V6

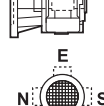
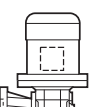
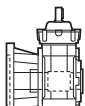
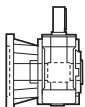
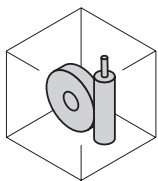

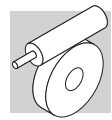

16 RADIALKRÄFTE

16.1 Berechnung der Überhängenden Last

Die mit den Antriebs- und/oder Abtriebswellen des Getriebes verbundenen Antriebsorgane bilden Kräfte, die in radiale Richtung auf die Welle selbst wirken.

Das Ausmaß dieser Kräfte muß mit der Festigkeit des Systems aus Getriebewelle/-lager kompatibel sein, insbesondere muß der absolute Wert der angetragenen Belastung (R_{c1} für Antriebswelle und R_{c2} für Abtriebswelle) unter dem in den Tabellen der Technischen Daten angegebenen Nennwert (R_{n1} für Antriebswelle und R_{n2} für Abtriebswelle) liegen.

In den nachstehenden Formeln bezieht sich die Angabe (1) auf die Maße der Antriebswelle, die Angabe (2) auf die Abtriebswelle.

Die von einem externen Antrieb erzeugte Kraft kann, recht genau, anhand der nachstehenden Formel berechnet werden:

$$R_c = \frac{2000 \times M \times K_r}{d}$$

$K_r = 1$		M [Nm]	
$K_r = 1.25$		d [mm]	
$K_r = 1.5 - 2.0$			

16.2 Überprüfung der Radiallast

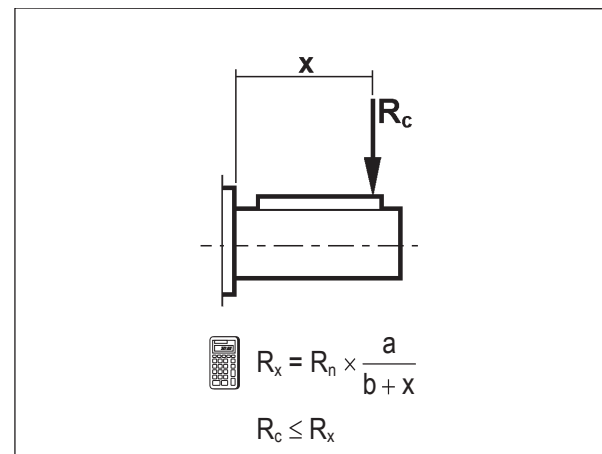
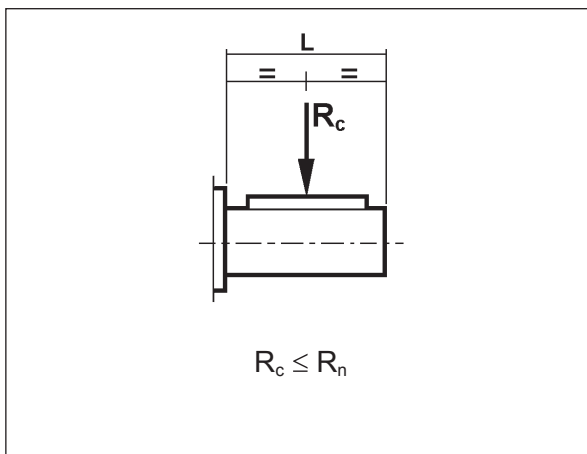

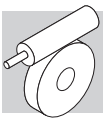

16.3 Getriebekonstanten

	Abtriebswelle		$R_{n2} \text{ max}$ [N]
	a	b	
VF 27	56	44	600
VF 30	60	45	1700
VF 44 - VFR 44 - VF/VF 30/44	71	51	2500
VF 49 - VFR 49 - VF/VF 30/49	99	69	3450
W 63 - WR 63 - VF/W 30/63	132	102	5000
W 75 - WR 75 - VF/W 44/75	139	109	6200
W 86 - WR 86 - VF/W 44/86	149	119	7000
W 110 - WR 110 - VF/W 49/110	173	136	8000
VF 130 - VFR 130 - W/VF 63/130	182	142	13800
VF 150 - VFR 150 - W/VF 86/150	198	155	16000
VF 185 - VFR 185 - W/VF 86/185	220	170	19500
VF 210 - VFR 210 - W/VF 130/210	268	203	34500
VF 250 - VFR 250 - W/VF 130/250	334	252	52000

17 AXIALKRÄFTE

Die Werte der zulässigen, auf die Antriebswelle [A_{n1}] und auf die Abtriebswelle [A_{n2}] einwirkenden Axialkräfte können unter Bezugnahme auf den jeweiligen Wert der Radialkraft [R_{n1}] und [R_{n2}] anhand der nachstehenden Angaben berechnet werden:

$$\begin{aligned} A_{n1} &= R_{n1} \times 0,2 \\ A_{n2} &= R_{n2} \times 0,2 \end{aligned} \quad (14)$$

Die so errechneten Werte der zulässigen Axialkräfte beziehen sich auf den Fall, in dem die Axialkräfte gleichzeitig mit den Nennradialkräften einwirken.

Nur im Fall, es keine Radialbelastung auf die Getriebewelle gibt, ist der Wert der zulässigen Axialbelastung [A_n] gleich zu 50% der zulässigen Radialbelastung [R_n] auf die gleiche Welle. In Anwesenheit von übermäßigen Axialkräften, oder stark auf die Radialkräfte einwirkende Kräfte, wird im Hinblick auf eine genaue Kontrolle empfohlen, sich mit dem Technischen Kundendienst der Bonfiglioli Riduttori in Verbindung zu setzen.

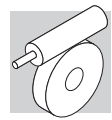

17.1 Maximal zulässige Radialkräfte bei der Bauform FR

Um den Verwendungen entsprechen zu können, die sehr hohe Axialkräfte erfordern, wurde die Bauform FR in den Größen VF 130, VF 150 und VF 185 entwickelt. Diese Bauform, deren äußeren Maße denen der Bauform FC identisch sind, kann die in der nachstehenden Tabelle aufgeführten (weit über den von den Standardformen zugelassenen liegenden) und sich auf das Übersetzungsverhältnis [i] und die Drehrichtung +/- der Abtriebswelle bezogenen Axialkräfte aufnehmen.

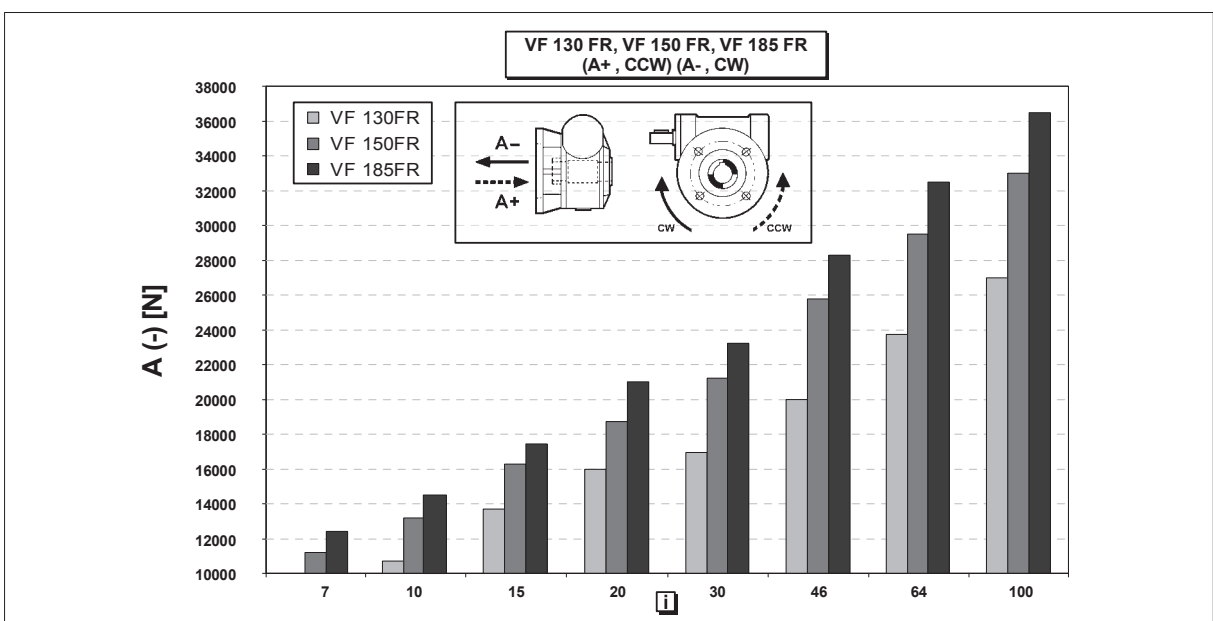
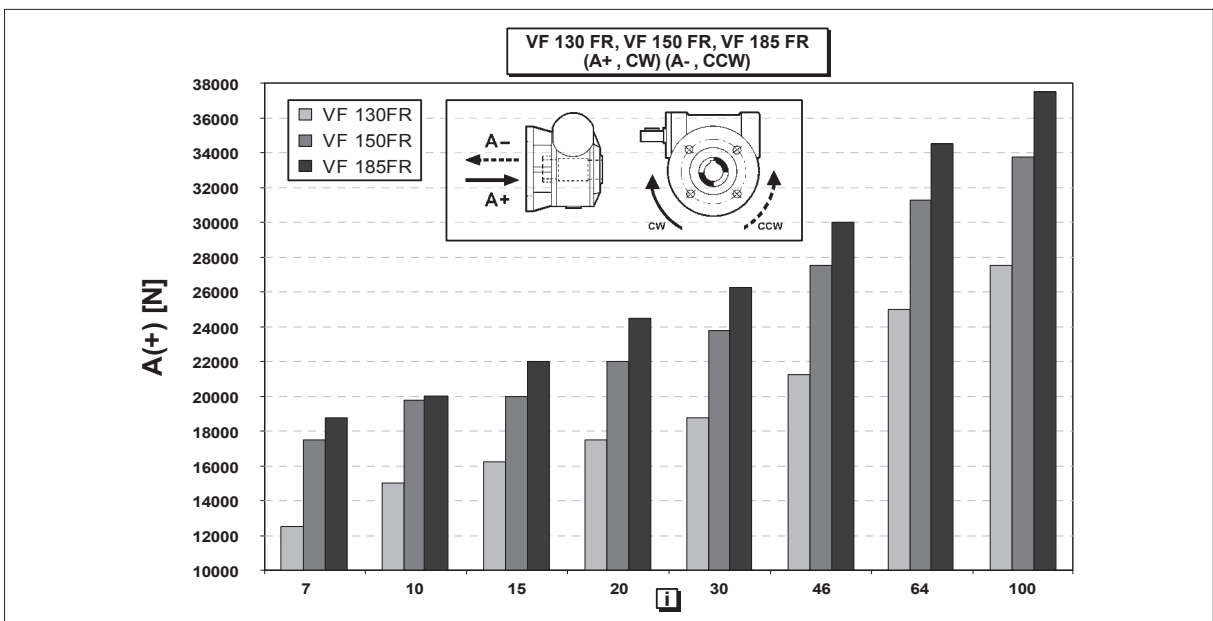
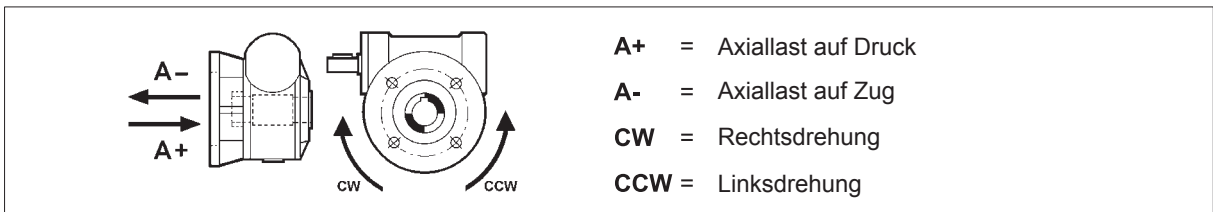

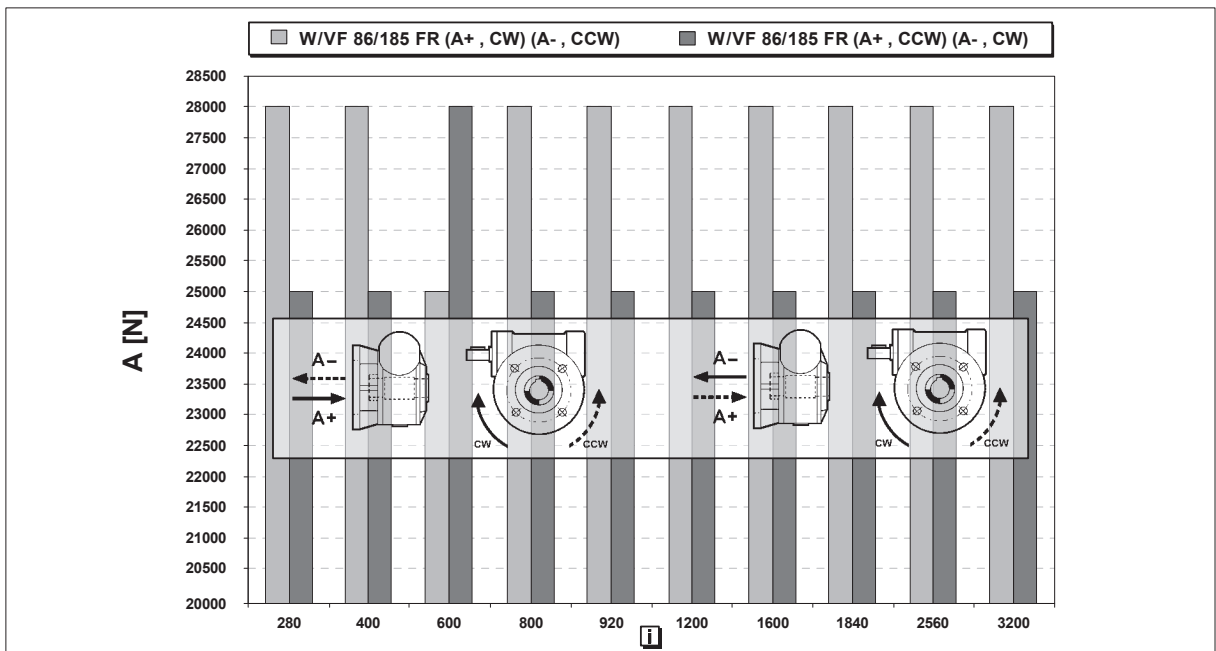
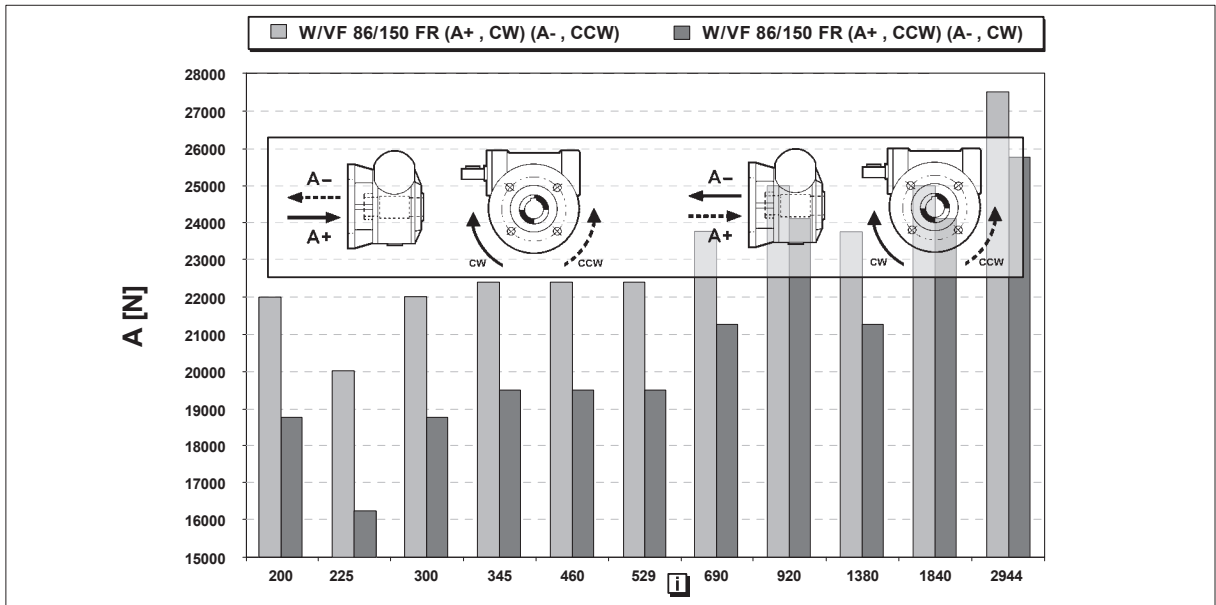
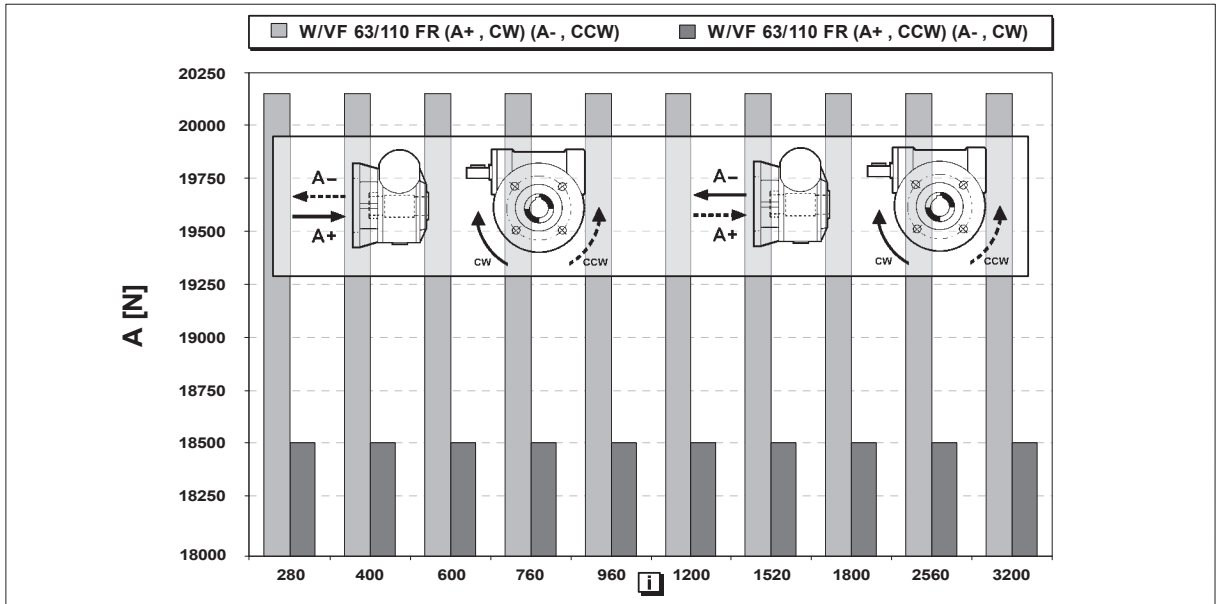



18 WIRKUNGSGRAD

Der Wirkungsgrad $[\eta]$ hängt von den folgenden Parametern ab:

- Eingriffswinkel
- Schmierung
- Einlaufen des Getriebes

Dabei ist auch zu berücksichtigen, daß der beste Wert erst nach einer Einlaufphase von einigen Stunden erreicht wird, aus Abbildung unter geht hervor, wann bei Getrieben, die mit Nenn Drehzahlen arbeiten der beste Wirkungsgrad erreicht wird. Für Anwendungsfälle mit intermittierendem Betrieb (Heben, Antrieb, sw.) ist es notwendig, die Motorleistung angemessen zu erhöhen, um den ungünstigen Wirkungsgrad des Getriebes während des Anfahrens zu überwinden.

Die Drehmomentwerte M_{n2} , die im Katalog angegeben sind, wurden im Hinblick auf den Wirkungsgrad von Getrieben berechnet, die bei einer Drehzahl von n_d laufen.

Die Abbildung zeigt die Zeit, die ungefähr notwendig ist, um den maximalen dynamischen Wirkungsgrad zu erreichen.

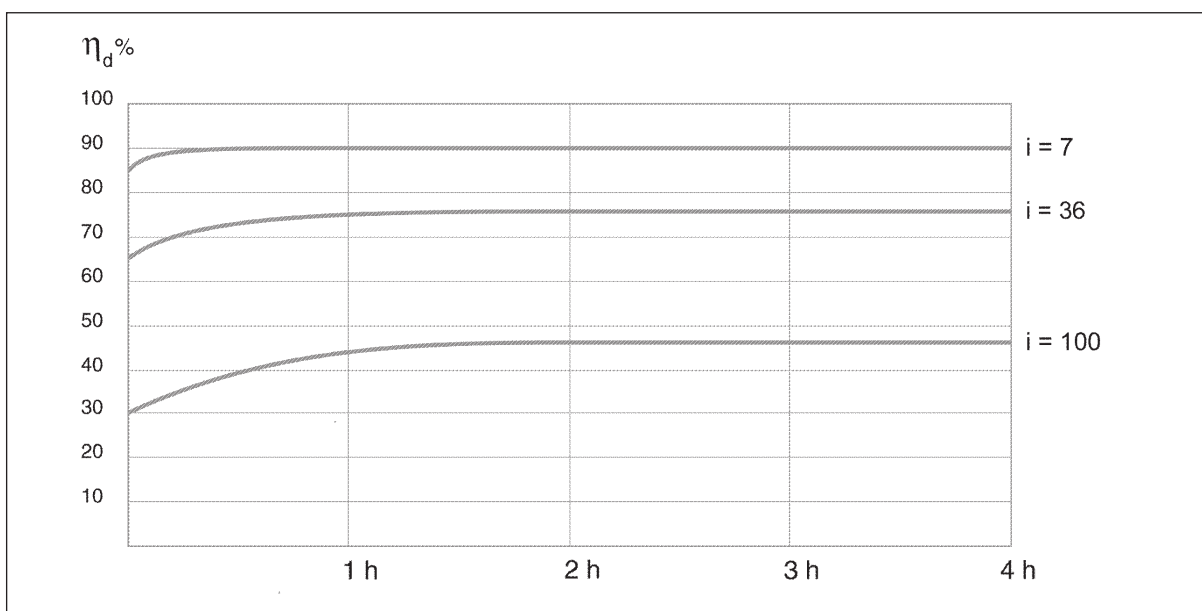

19 SELBSTHEMMUNG

Einige Applikationsarten können gelegentlich dazu führen, dass die Antriebübertragung über die Abtriebswelle erfolgt, während andere es erforderlich machen, dass die Last, auch ohne elektrische Versorgung, vom Getriebemotor in Position gehalten wird. Einige Schneckeneinheiten bieten die Eigenschaft der Nichtumkehrbarkeit und der Kennwert, der diese Eigenschaft am meisten beeinflusst, stellt sich in ihrem Wirkungsgrad dar. Insbesondere ist der statische Wirkungsgrad η_s für die statische Nichtumkehrbarkeit (Passage über eine Aussetzposition) verantwortlich, während der dynamische Wirkungsgrad η_d für die eventuelle dynamische Nichtumkehrbarkeit (kontinuierlicher Antrieb in die gleiche Richtung) zuständig ist. Die Nichtumkehrbarkeit kann sich bei längeren Übersetzungsverhältnissen ($i=64$ und höher) in anderen Maßen ausdrücken und so eine immer höhere Nichtumkehrbarkeit bieten.

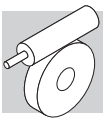

19.1 Statische Selbsthemmung

Unter dieser Bedingung ist bei Belastung der Abtriebswelle im Stillstand kein Durchlaufen möglich, jedoch sind kleine Bewegungen im Falle von Vibrationen nicht auszuschließen. Die theoretische Voraussetzung für eine statische Selbsthemmung ist:

$$\eta_s < 0.4 - 0.5 \quad (15)$$

wobei der statische Wirkungsgrad η_s ist (diesen Wert findet man in den Tabellen der technischen Daten der Getriebe). Das genaue Gegenteil, ein Weiterdrehen der Antriebswelle aus dem Stillstand, ergibt sich bei:

$$\eta_s > 0.5 \quad (16)$$

19.2 Dynamische Selbsthemmung

Diese Eigenschaft ist äußerst schwierig zu erreichen, da sie direkt von der Drehzahl, dem Wirkungsgrad und andauernden Vibrationen der Last abhängig ist.

Sie wird durch einen praktisch sofortigen Stillstand charakterisiert, wenn die Schneckenwelle nicht mehr angetrieben wird.

$$\eta_d < 0.5 \quad (17)$$

Die theoretische Voraussetzung für eine dynamische Selbsthemmung ist ein dynamischer Wirkungsgrad von bei vollen Betriebsbedingungen (den Wert findet man in den Tabellen der technischen Daten der Getriebe), während das Gegenteil bei einem Wirkungsgrad von:

$$\eta_d > 0.5 \quad (18)$$

Die Abbildung unter gibt Auskunft über die verschiedenen Reversierbarkeitsstufen, je nach Getriebeart und dem Untersetzungsverhältnis (die Angaben beziehen sich nur auf das Kräftepaar Schneckenwelle-Schneckenrad).

Natürlich dienen diese Daten nur zur allgemeinen Information, denn die Selbsthemmung kann wegen den bereits genannten Faktoren mehr oder weniger verstärkt sein.



Da es praktisch unmöglich ist, eine totale Selbsthemmung zu realisieren oder zu garantieren, muß man, falls diese unerlässlich sein sollte, eine äußere Bremse anbringen, die ein durch Vibrationen verursachtes Anlaufen ausschließt.



		Selbsthemmungsgrad												
		VF				W				VF				
Statische Reversierbarkeit	Dynamische Reversierbarkeit	27	30	44	49	63	75	86	110	130	150	185	210	250
ja	ja	—	—	7	7	7	7	7	7	7	7	7	7	7
ja	ja	7 10	7 10	10 14	10 14	10 12 15	10 15	10 15 20 23	10 15 20 23	10 15 20 23	10 15 20 23	10 15 20 23	10 15 20 23	
unsicher	ja	15 20 30	15 20 30	20 28 35	18 24 28 36	19 24 30 38	20 25 30 40	30 40 46 56	30 40 46 56	30 40 46 56 64	30 40 46 56 64	30 40 50 60	30 40 50 60	
no	leicht	40 60	40 60	46 60 70	45 60 70	45 64 80	50 60 80	64 80 100	64 80 100	80 100	80 100	80 100	60 80 100	80 100
no	no	70	70	100	80 100	100	100	—	—	—	—	—	—	—

20 WINKELSPIELE

In der nachstehenden Tabelle werden die Anhaltswerte für das Winkelspiel bezüglich der Abtriebswelle, d.h. also bei blockierter Antriebswelle, gegeben. Das Maß ist durch das Ansetzen eines Drehmoments von 5 Nm an der Abtriebswelle erhältlich

Winkelspiele (Antriebswelle blockiert)		
	$\Delta\gamma$ [']	$\Delta\gamma$ [rad]
VF 30	33' ± 10'	0.00873 ± 0.00291
VF 44	25' ± 7'	0.00728 ± 0.00145
VFR 44	30' ± 10'	0.00873 ± 0.00291
VF 49	22' ± 7'	0.00728 ± 0.00145
VFR 49	30' ± 10'	0.00873 ± 0.00291
W 63	20' ± 4'	0.00582 ± 0.00145
WR 63	25' ± 5'	0.00728 ± 0.00145
W 75	18' ± 4'	0.00582 ± 0.00145
WR 75	22' ± 5'	0.00640 ± 0.00145
W 86	15' ± 4'	0.00436 ± 0.00145
WR 86	20' ± 5'	0.00582 ± 0.00145
W 110	9' ± 2'	0.00436 ± 0.00145
WR 110	18' ± 5'	0.00524 ± 0.00145
VF 130	12' ± 3'	0.00349 ± 0.00087
VFR 130	15' ± 3'	0.00436 ± 0.00087
VF 150	12' ± 3'	0.00349 ± 0.00087
VFR 150	15' ± 3'	0.00436 ± 0.00087
VF 185	10' ± 3'	0.00291 ± 0.00087
VFR 185	13' ± 3'	0.00378 ± 0.00087
VF 210	Rückfrage an Hersteller	
VFR 210		
VF 250		
VFR 250		







21 GETRIEBEMOTOREN-AUSWAHLTABELLEN







Die Auswahl der Motoren ohne Bremse erfolgt nach den Vorgaben der Verordnung EG 640/2009 (siehe abschnitt **M** dieses Katalogs). Für Nennleistungen unter 0,75 kW können die BN/M-Motoren vorgesehen werden.

Die Verordnung EG 640/2009 gilt nicht für die Bremsmotoren, d.h., bei der Auswahl der Bremsmotoren sind die BN/M-Motoren in Betracht zu ziehen, ohne den Wert der Nennleistung zu berücksichtigen. Die BX, BE, MX und ME-Bremsmotoren sind auf Anfrage verfügbar.

0.04 kW



n ₂ min-1	M ₂ Nm	S	i	R _{n2} N	 IE1	 IEC	 IEC	 IEC	
19.3	9	1.0	70	600					
22.5	8	1.1	60	600					
34	6	1.4	40	600					
45	5	1.7	30	600					
68	4	2.2	20	600					
90	3	2.8	15	600					
135	2	3.8	10	600					
193	2	5.5	7	600					
						VF 27_70	P27	BN27A4	105
						VF 27_60	P27	BN27A4	105
						VF 27_40	P27	BN27A4	105
						VF 27_30	P27	BN27A4	105
						VF 27_20	P27	BN27A4	105
						VF 27_15	P27	BN27A4	105
						VF 27_10	P27	BN27A4	105
						VF 27_7	P27	BN27A4	105

0.06 kW



n ₂ min-1	M ₂ Nm	S	i	R _{n2} N	 IE1	 IEC	 IEC	 IEC	
0.59	203	1.0	2280	5000					
0.89	155	1.4	1520	5000					
1.1	122	1.7	1200	5000					
1.5	115	1.8	900	5000					
1.9	113	1.9	720	5000					
2.5	85	1.1	540	3450					
2.8	50	1.0	500	5000					
3.2	73	1.3	420	3450					
4.0	54	1.0	350	5000					
4.3	53	1.8	315	3450					
4.5	59	1.0	300	2500					
5.8	50	1.2	230	2500					
7.7	42	1.5	175	2500					
9.6	36	1.4	140	2500					
13.4	29	1.8	100	2500					
19.1	22	1.8	70	2500					
19.3	14	1.1	70	1600					
22.5	13	1.5	60	1600					
34	10	0.9	40	600					
34	10	1.9	40	1650					
						VF/W 30/63_2280	P56	BN56A4	123
						VF/W 30/63_1520	P56	BN56A4	123
						VF/W 30/63_1200	P56	BN56A4	123
						VF/W 30/63_900	P56	BN56A4	123
						VF/W 30/63_720	P56	BN56A4	123
						VF/VF 30/49_540	P56	BN56A4	118
						VFR 44_500	S44	BN44B4	110
						VF/VF 30/49_420	P56	BN56A4	118
						VFR 44_350	S44	BN44B4	110
						VF/VF 30/49_315	P56	BN56A4	118
						VFR 44_300	S44	BN44B4	110
						VFR 44_230	S44	BN44B4	110
						VFR 44_175	S44	BN44B4	110
						VFR 44_140	S44	BN44B4	110
						VFR 44_100	S44	BN44B4	110
						VFR 44_70	S44	BN44B4	110
						VF 30_70	P56	BN56A4	106
						VF 30_60	P56	BN56A4	106
						VF 27_40	P27	BN27B4	105
						VF 30_40	P56	BN56A4	106

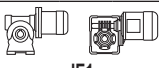

0.06 kW

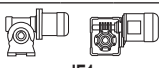

n ₂ min-1	M ₂ Nm	S	i	R _{n2} N	 IE1	 IEC		
45	8	1.1	30	600		VF 27_30	P27 BN27B4	105
45	8	2.4	30	1340		VF 30_30	P56 BN56A4	106
68	6	1.5	20	600		VF 27_20	P27 BN27B4	105
68	6	2.9	20	1180		VF 30_20	P56 BN56A4	106
90	5	1.9	15	600		VF 27_15	P27 BN27B4	105
90	5	3.7	15	1080		VF 30_15	P56 BN56A4	106
135	4	2.6	10	590		VF 27_10	P27 BN27B4	105
135	3	4.7	10	950		VF 30_10	P56 BN56A4	106
193	2	3.6	7	530		VF 27_7	P27 BN27B4	105
193	2	6.4	7	840		VF 30_7	P56 BN56A4	106

0.09 kW



n ₂ min-1	M ₂ Nm	S	i	R _{n2} N	 IE1	 IEC		
0.31	574	1.8	2800	8000		VF/W 49/110_2800	P63 BN63A6	135
0.42	579	1.0	2116	7000		VF/W 44/86_2116	P63 BN63A6	131
0.43	505	2.1	2070	8000		VF/W 49/110_2070	P63 BN63A6	135
0.48	503	1.1	1840	7000		VF/W 44/86_1840	P63 BN63A6	131
0.53	485	2.2	1656	8000		VF/W 49/110_1656	P63 BN63A6	135
0.64	377	1.5	1380	7000		VF/W 44/86_1380	P63 BN63A6	131
0.65	369	2.8	1350	8000		VF/W 49/110_1350	P63 BN63A6	135
0.73	363	1.1	1200	5750		VF/W 44/75_1200	P63 BN63A6	127
0.81	316	3.3	1080	8000		VF/W 49/110_1080	P63 BN63A6	135
0.89	232	0.9	1520	5000		VF/W 30/63_1520	P56 BN56B4	123
0.96	323	1.2	920	5750		VF/W 44/75_920	P63 BN63A6	127
0.96	332	1.7	920	7000		VF/W 44/86_920	P63 BN63A6	131
0.98	255	0.9	900	5000		VF/W 30/63_900	P63 BN63A6	123
1.1	183	1.1	1200	5000		VF/W 30/63_1200	P56 BN56B4	123
1.2	225	1.0	720	5000		VF/W 30/63_720	P63 BN63A6	123
1.3	267	1.5	700	5750		VF/W 44/75_700	P63 BN63A6	127
1.3	253	2.2	700	7000		VF/W 44/86_700	P63 BN63A6	131
1.5	172	1.2	900	5000		VF/W 30/63_900	P56 BN56B4	123
1.7	210	1.9	525	5750		VF/W 44/75_525	P63 BN63A6	127
1.7	200	2.8	525	7000		VF/W 44/86_525	P63 BN63A6	131
1.9	170	1.2	720	5000		VF/W 30/63_720	P56 BN56B4	123
2.2	164	2.4	400	5750		VF/W 44/75_400	P63 BN63A6	127
2.2	160	3.4	400	7000		VF/W 44/86_400	P63 BN63A6	131
2.4	145	1.4	570	5000		VF/W 30/63_570	P56 BN56B4	123
2.9	111	1.2	300	5000		WR 63_300	P63 BN63A6	122
2.9	120	1.7	300	6200		WR 75_300	P63 BN63A6	126
2.9	132	2.4	300	7000		WR 86_300	P63 BN63A6	130
3.0	117	1.8	450	5000		VF/W 30/63_450	P56 BN56B4	123
3.2	110	0.9	420	3450		VF/VF 30/49_420	P56 BN56B4	118
3.7	101	1.4	240	5000		WR 63_240	P63 BN63A6	122
3.7	105	2.1	240	6200		WR 75_240	P63 BN63A6	126
3.7	117	2.6	240	7000		WR 86_240	P63 BN63A6	130
4.2	84	0.9	210	3450		VFR 49_210	P63 BN63A6	116
4.3	80	1.2	315	3450		VF/VF 30/49_315	P56 BN56B4	118
4.3	84	2.5	315	5000		VF/W 30/63_315	P56 BN56B4	123
4.6	88	1.7	192	5000		WR 63_192	P63 BN63A6	122
4.9	79	0.9	180	3450		VFR 49_180	P63 BN63A6	116
4.9	90	3.1	180	6200		WR 75_180	P63 BN63A6	126
5.2	94	4.2	168	7000		WR 86_168	P63 BN63A6	130
5.5	62	1.0	245	2500		VF/VF 30/44_245	P56 BN56B4	112
6.5	66	1.2	135	3450		VFR 49_135	P63 BN63A6	116
6.5	71	2.5	135	5000		WR 63_135	P63 BN63A6	122
7.7	63	1.0	175	2900		VFR 44_175	S44 BN44C4	110
7.7	65	3.1	114	5000		WR 63_114	P63 BN63A6	122
8.1	58	1.4	108	3450		VFR 49_108	P63 BN63A6	116
8.8	41	1.3	100	3300		VF 49_100	P63 BN63A6	114
9.6	54	0.9	140	2900		VFR 44_140	S44 BN44C4	110
9.8	55	3.8	90	5000		WR 63_90	P63 BN63A6	122
10.5	48	1.9	84	3450		VFR 49_84	P63 BN63A6	116
11.0	37	1.6	80	3300		VF 49_80	P63 BN63A6	114
12.2	45	1.8	72	3450		VFR 49_72	P63 BN63A6	116
12.2	48	4.0	72	5000		WR 63_72	P63 BN63A6	122
12.6	35	1.1	70	2300		VF 44_70	P63 BN63A6	108
12.6	34	1.8	70	3300		VF 49_70	P63 BN63A6	114
13.4	43	1.2	100	2900		VFR 44_100	S44 BN44C4	110



0.09 kW





n ₂ min-1	M ₂ Nm	S	i	R _{n2} N	 IE1	 IEC	
14.7	32	1.4	60	2300		VF 44_60	P63 BN63A6 108
14.7	34	1.7	60	3300		VF 49_60	P63 BN63A6 114
16.3	36	2.2	54	3450		VFR 49_54	P63 BN63A6 116
19.1	33	1.2	70	2900		VFR 44_70	S44 BN44C4 110
19.1	27	1.8	46	2300		VF 44_46	P63 BN63A6 108
19.6	26	2.7	45	3300		VF 49_45	P63 BN63A6 114
21.0	30	2.8	42	3360		VFR 49_42	P63 BN63A6 116
22.0	22	0.9	40	1560		VF 30_40	P63 BN63A6 106
22.5	19	1.0	60	1600		VF 30_60	P56 BN56B4 106
24.4	22	3.4	36	3300		VF 49_36	P63 BN63A6 114
25.1	22	2.2	35	2300		VF 44_35	P63 BN63A6 108
29.3	18	1.2	30	1440		VF 30_30	P63 BN63A6 106
31	18	2.7	28	2300		VF 44_28	P63 BN63A6 108
34	15	1.2	40	1410		VF 30_40	P56 BN56B4 106
44	14	1.5	20	1230		VF 30_20	P63 BN63A6 106
44	14	3.1	20	2300		VF 44_20	P63 BN63A6 108
45	12	1.6	30	1290		VF 30_30	P56 BN56B4 106
59	11	1.8	15	1170		VF 30_15	P63 BN63A6 106
68	9	1.9	20	1140		VF 30_20	P56 BN56B4 106
69	9	1.0	20	600		VF 27_20	P27 BN27C4 105
88	8	2.3	10	1050		VF 30_10	P63 BN63A6 106
90	7	2.5	15	1050		VF 30_15	P56 BN56B4 106
92	7	1.3	15	600		VF 27_15	P27 BN27C4 105
126	6	3.2	7	920		VF 30_7	P63 BN63A6 106
135	5	3.1	10	920		VF 30_10	P56 BN56B4 106
138	5	1.7	10	565		VF 27_10	P27 BN27C4 105
193	4	4.3	7	820		VF 30_7	P56 BN56B4 106
197	4	2.5	7	510		VF 27_7	P27 BN27C4 105

0.12 kW



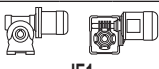

n ₂ min-1	M ₂ Nm	S	i	R _{n2} N	 IE1	 IEC	
0.31	775	1.4	2800	8000		VF/W 49/110_2800	P63 BN63B6 135
0.47	588	1.7	2800	8000		VF/W 49/110_2800	P63 BN63A4 135
0.53	654	1.6	1656	8000		VF/W 49/110_1656	P63 BN63B6 135
0.62	518	1.0	2116	7000		VF/W 44/86_2116	P63 BN63A4 131
0.63	507	2.0	2070	8000		VF/W 49/110_2070	P63 BN63A4 135
0.71	483	1.0	1840	7000		VF/W 44/86_1840	P63 BN63A4 131
0.79	435	2.3	1656	8000		VF/W 49/110_1656	P63 BN63A4 135
0.95	386	1.3	1380	7000		VF/W 44/86_1380	P63 BN63A4 131
0.97	354	2.8	1350	8000		VF/W 49/110_1350	P63 BN63A4 135
1.2	293	3.4	1080	8000		VF/W 49/110_1080	P63 BN63A4 135
1.4	322	1.1	920	5750		VF/W 44/75_920	P63 BN63A4 127
1.4	322	1.6	920	7000		VF/W 44/86_920	P63 BN63A4 131
1.5	236	0.9	900	5000		VF/W 30/63_900	P63 BN63A4 123
1.8	233	0.9	720	5000		VF/W 30/63_720	P63 BN63A4 123
1.9	257	1.4	700	5750		VF/W 44/75_700	P63 BN63A4 127
1.9	239	2.1	700	7000		VF/W 44/86_700	P63 BN63A4 131
2.3	199	1.1	570	5000		VF/W 30/63_570	P63 BN63A4 123
2.5	202	1.8	525	5750		VF/W 44/75_525	P63 BN63A4 127
2.5	193	2.6	525	7000		VF/W 44/86_525	P63 BN63A4 131
2.9	150	0.9	300	5000		WR 63_300	P63 BN63B6 122
2.9	162	1.2	300	6200		WR 75_300	P63 BN63B6 126
2.9	178	1.7	300	7000		WR 86_300	P63 BN63B6 130
2.9	161	1.3	450	5000		VF/W 30/63_450	P63 BN63A4 123
3.3	161	2.3	400	5750		VF/W 44/75_400	P63 BN63A4 127
3.3	143	3.5	400	7000		VF/W 44/86_400	P63 BN63A4 131
3.6	136	1.0	240	5000		WR 63_240	P63 BN63B6 122
3.6	142	1.5	240	6200		WR 75_240	P63 BN63B6 126
3.6	142	1.6	240	5000		VF/W 30/63_240	P63 BN63B6 123
3.6	158	2.0	240	7000		WR 86_240	P63 BN63B6 130
4.2	110	0.9	315	3450		VF/VF 30/49_315	P63 BN63A4 118
4.2	116	1.8	315	5000		VF/W 30/63_315	P63 BN63A4 123
4.4	108	1.2	300	5000		WR 63_300	P63 BN63A4 122
4.4	115	1.6	300	6200		WR 75_300	P63 BN63A4 126
4.4	129	2.1	300	7000		WR 86_300	P63 BN63A4 130
4.4	134	2.8	300	5750		VF/W 44/75_300	P63 BN63A4 127
4.8	121	2.3	180	6200		WR 75_180	P63 BN63B6 126
5.2	126	3.1	168	7000		WR 86_168	P63 BN63B6 130
5.2	125	3.0	250	5750		VF/W 44/75_250	P63 BN63A4 127



0.12 kW



n ₂ min-1	M ₂ Nm	S	i	R _{n2} N	 IE1	 IEC	 IE1		
5.5	94	1.0	240	3450			VF/VF 30/49_240	P63 BN63A4	118
5.5	97	1.4	240	5000			WR 63_240	P63 BN63A4	122
5.5	103	2.1	240	6200			WR 75_240	P63 BN63A4	126
5.5	99	2.1	240	5000			VF/W 30/63_240	P63 BN63A4	123
5.5	111	2.7	240	7000			WR 86_240	P63 BN63A4	130
5.8	109	2.9	150	6200			WR 75_150	P63 BN63B6	126
6.4	89	0.9	135	3300			VFR 49_135	P63 BN63B6	116
6.4	96	1.9	135	5000			WR 63_135	P63 BN63B6	122
6.8	86	1.8	192	5000			WR 63_192	P63 BN63A4	122
7.3	76	0.9	180	3300			VFR 49_180	P63 BN63A4	116
7.3	87	2.7	180	6200			WR 75_180	P63 BN63A4	126
8.7	55	0.9	100	3300			VF 49_100	P63 BN63B6	114
9.7	64	1.4	135	3450			VFR 49_135	P63 BN63A4	116
9.7	68	2.5	135	5000			WR 63_135	P63 BN63A4	122
10.9	50	1.2	80	3300			VF 49_80	P63 BN63B6	114
11.5	61	3.0	114	5000			WR 63_114	P63 BN63A4	122
12.1	55	1.5	108	3450			VFR 49_108	P63 BN63A4	116
13.1	41	1.2	100	3150			VF 49_100	P63 BN63A4	114
14.5	43	1.1	60	2300			VF 44_60	P63 BN63B6	108
15.3	53	3.6	57	5000			WR 63_57	P63 BN63B6	122
15.6	46	1.9	84	3450			VFR 49_84	P63 BN63A4	116
16.4	36	1.5	80	3150			VF 49_80	P63 BN63A4	114
18.2	42	1.8	72	3430			VFR 49_72	P63 BN63A4	116
18.7	34	0.9	70	3300			VF 44_70	P63 BN63A4	108
18.7	33	1.7	70	3150			VF 49_70	P63 BN63A4	114
21.8	30	1.3	60	2300			VF 44_60	P63 BN63A4	108
21.8	30	1.9	60	3150			VF 49_60	P63 BN63A4	114
24.3	34	2.2	54	3140			VFR 49_54	P63 BN63A4	116
28.5	25	1.5	46	2300			VF 44_46	P63 BN63A4	108
29.0	24	0.9	30	1360			VF 30_30	P63 BN63B6	106
29.1	25	2.6	45	3040			VF 49_45	P63 BN63A4	114
31	27	2.9	42	2920			VFR 49_42	P63 BN63A4	116
33	21	0.9	40	1360			VF 30_40	P63 BN63A4	106
36	21	3.3	36	2830			VF 49_36	P63 BN63A4	114
37	21	1.9	35	2300			VF 44_35	P63 BN63A4	108
44	17	1.2	30	1250			VF 30_30	P63 BN63A4	106
47	17	2.2	28	2300			VF 44_28	P63 BN63A4	108
58	15	1.4	15	1130			VF 30_15	P63 BN63B6	106
62	14	2.7	14	2150			VF 44_14	P63 BN63B6	108
66	13	1.4	20	1110			VF 30_20	P63 BN63A4	106
66	13	2.9	20	2100			VF 44_20	P63 BN63A4	108
87	10	1.8	15	1020			VF 30_15	P63 BN63A4	106
94	10	2.9	14	1870			VF 44_14	P63 BN63A4	108
124	8	2.4	7	900			VF 30_7	P63 BN63B6	106
131	7	2.3	10	900			VF 30_10	P63 BN63A4	106
138	6	1.1	20	560			VF 27_20	P27 BN27C2	105
138	7	2.2	20	840			VF 30_20	P56 BN56B2	106
183	5	1.4	15	520			VF 27_15	P27 BN27C2	105
187	5	3.1	7	810			VF 30_7	P63 BN63A4	106
275	4	2.0	10	460			VF 27_10	P27 BN27C2	105
275	4	3.4	10	740			VF 30_10	P56 BN56B2	106
393	3	2.8	7	410			VF 27_7	P27 BN27C2	105
393	3	4.7	7	660			VF 30_7	P56 BN56B2	106

0.18 kW

n ₂ min-1	M ₂ Nm	S	i	R _{n2} N	 IE1	 IEC	 IE1		
0.28	978	1.9	3200	13800			W/VF 63/130_3200	P71 BN71A6	141
0.28	1345	3.3	3200	19500			W/VF 86/185_3200	P71 BN71A6	153
0.31	1406	1.9	2944	16000			W/VF 86/150_2944	P71 BN71A6	147
0.35	1027	1.8	2560	13800			W/VF 63/130_2560	P71 BN71A6	141
0.35	1320	3.3	2560	19500			W/VF 86/185_2560	P71 BN71A6	153
0.47	875	1.1	2800	8000			VF/W 49/110_2800	P63 BN63B4	135
0.49	1265	2.1	1840	16000			W/VF 86/150_1840	P71 BN71A6	147
0.50	894	2.1	1800	13800			W/VF 63/130_1800	P71 BN71A6	141
0.54	949	1.1	1656	8000			VF/W 49/110_1656	P71 BN71A6	135
0.59	871	2.1	1520	13800			W/VF 63/130_1520	P71 BN71A6	141
0.64	755	1.3	2070	8000			VF/W 49/110_2070	P63 BN63B4	135
0.65	1054	2.6	1380	16000			W/VF 86/150_1380	P71 BN71A6	147
0.75	733	2.5	1200	13800			W/VF 63/130_1200	P71 BN71A6	141
0.80	647	1.5	1656	8000			VF/W 49/110_1656	P63 BN63B4	135







0.18 kW



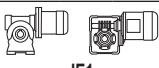

n ₂ min-1	M ₂ Nm	S	i	R _{n2} N	 IE1			 IE1				
0.94	642	2.9	960	13800				W/VF 63/130_960	P71	BN71A6	141	
0.98	527	1.9	1350	8000				VF/W 49/110_1350	P63	BN63B4	135	
0.98	756	3.6	920	16000				W/VF 86/150_920	P71	BN71A6	147	
1.2	537	3.4	760	13800				W/VF 63/130_760	P71	BN71A6	141	
1.2	436	2.3	1080	8000				VF/W 49/110_1080	P63	BN63B4	135	
1.4	479	1.0	920	7000				VF/W 44/86_920	P63	BN63B4	131	
1.7	391	1.4	525	7000				VF/W 44/86_525	P71	BN71A6	131	
1.8	375	2.7	720	8000				VF/W 49/110_720	P63	BN63B4	135	
1.9	356	1.4	700	7000				VF/W 44/86_700	P63	BN63B4	131	
2.3	321	1.2	400	5750				VF/W 44/75_400	P71	BN71A6	127	
2.3	313	1.8	400	7000				VF/W 44/86_400	P71	BN71A6	131	
2.3	344	3.1	400	8000				VF/W 49/110_400	P71	BN71A6	135	
2.4	288	3.5	540	8000				VF/W 49/110_540	P63	BN63B4	135	
2.5	301	1.2	525	5750				VF/W 44/75_525	P63	BN63B4	127	
2.5	287	1.7	525	7000				VF/W 44/86_525	P63	BN63B4	131	
3.0	258	1.2	300	7000				WR 86_300	P71	BN71A6	130	
3.0	264	1.5	300	5750				VF/W 44/75_300	P71	BN71A6	127	
3.0	275	2.1	300	8000				WR 110_300	P71	BN71A6	134	
3.0	241	2.3	300	7000				VF/W 44/86_300	P71	BN71A6	131	
3.0	269	3.9	300	8000				VF/W 49/110_300	P71	BN71A6	135	
3.3	240	1.5	400	5750				VF/W 44/75_400	P63	BN63B4	127	
3.3	214	2.3	400	7000				VF/W 44/86_400	P63	BN63B4	131	
3.8	206	1.1	240	6200				WR 75_240	P71	BN71A6	126	
3.8	229	1.4	240	7000				WR 86_240	P71	BN71A6	130	
3.8	243	2.4	240	8000				WR 110_240	P71	BN71A6	134	
3.9	233	2.4	230	7000				VF/W 44/86_230	P71	BN71A6	131	
4.2	172	1.2	315	5000				VF/W 30/63_315	P63	BN63B4	123	
4.4	172	1.0	300	6200				WR 75_300	P63	BN63B4	126	
4.4	191	1.4	300	7000				WR 86_300	P63	BN63B4	130	
4.4	199	1.9	300	5750				VF/W 44/75_300	P63	BN63B4	127	
4.4	176	2.8	300	7000				VF/W 44/86_300	P63	BN63B4	131	
4.7	202	1.9	192	7000				WR 86_192	P71	BN71A6	130	
5.0	175	1.6	180	6200				WR 75_180	P71	BN71A6	126	
5.3	186	2.0	250	5750				VF/W 44/75_250	P63	BN63B4	127	
5.4	183	2.1	168	7000				WR 86_168	P71	BN71A6	130	
5.5	144	0.9	240	5000				WR 63_240	P63	BN63B4	122	
5.5	153	1.4	240	6200				WR 75_240	P63	BN63B4	126	
5.5	147	1.4	240	5000				VF/W 30/63_240	P63	BN63B4	123	
5.5	166	1.8	240	7000				WR 86_240	P63	BN63B4	130	
5.7	162	3.1	230	7000				VF/W 44/86_230	P63	BN63B4	131	
6.0	158	2.0	150	6200				WR 75_150	P71	BN71A6	126	
6.5	161	2.7	138	7000				WR 86_138	P71	BN71A6	130	
6.9	128	1.2	192	5000				WR 63_192	P63	BN63B4	122	
6.9	145	2.3	192	7000				WR 86_192	P63	BN63B4	130	
7.3	129	1.8	180	6200				WR 75_180	P63	BN63B4	126	
7.5	138	2.4	120	6200				WR 75_120	P71	BN71A6	126	
7.9	131	2.7	168	7000				WR 86_168	P63	BN63B4	130	
7.9	126	1.6	114	5000				WR 63_114	P71	BN71A6	122	
8.8	113	2.3	150	6200				WR 75_150	P63	BN63B4	126	
9.0	88	1.4	100	5000	W 63_100	S1	M1SC6	120	W 63_100	P71	BN71A6	122
9.0	96	1.7	100	6200	W 75_100	S1	M1SC6	124	W 75_100	P71	BN71A6	125
9.0	105	2.4	100	7000	W 86_100	S1	M1SC6	128	W 86_100	P71	BN71A6	129
9.8	102	1.7	135	5000				WR 63_135	P63	BN63B4	122	
10.0	107	1.9	90	5000				WR 63_90	P71	BN71A6	122	
11.0	98	3.1	120	6200				WR 75_120	P63	BN63B4	126	
11.3	79	1.6	80	5000	W 63_80	S1	M1SC6	120	W 63_80	P71	BN71A6	122
11.3	83	2.4	80	6200	W 75_80	S1	M1SC6	124	W 75_80	P71	BN71A6	125
11.3	90	3.1	80	7000	W 86_80	S1	M1SC6	128	W 86_80	P71	BN71A6	129
11.6	91	2.0	114	5000				WR 63_114	P63	BN63B4	122	
12.0	100	3.3	75	6200				WR 75_75	P71	BN71A6	126	
12.2	82	1.0	108	3450				VFR 49_108	P63	BN63B4	116	
14.7	75	2.5	90	5000				WR 63_90	P63	BN63B4	122	
15.0	61	1.1	60	3000				VF 49_60	P71	BN71A6	114	
15.0	60	1.1	180	3300				VFR 49_180	P63	BN63A2	116	
15.7	68	1.3	84	3420				VFR 49_84	P63	BN63B4	116	
16.5	54	1.0	80	3150				VF 49_80	P63	BN63B4	114	
18.3	63	1.2	72	3270				VFR 49_72	P63	BN63B4	116	
18.3	66	2.8	72	5000				WR 63_72	P63	BN63B4	122	
18.9	49	1.1	70	3150				VF 49_70	P63	BN63B4	114	
20.0	50	1.4	135	3280				VFR 49_135	P63	BN63A2	116	
20.0	54	2.9	45	5000				W 63_45	P71	BN71A6	122	
22.0	45	0.9	60	2300				VF 44_60	P63	BN63B4	108	
22.0	45	1.3	60	3150				VF 49_60	P63	BN63B4	114	
23.2	54	3.3	57	4910				WR 63_57	P63	BN63B4	122	
24.4	50	1.5	54	3010				VFR 49_54	P63	BN63B4	116	
28.7	38	1.0	46	2500				VF 44_46	P63	BN63B4	108	



0.18 kW





n ₂ min-1	M ₂ Nm	S	i	R _{n2} N	 IE1	 IEC	 IE1		
29.3	37	1.8	45	2300		VF 49_45	P63	BN63B4	114
31	40	1.9	42	2810		VFR 49_42	P63	BN63B4	116
32	36	1.4	28	2290		VF 44_28	P71	BN71A6	108
37	31	2.2	36	2760		VF 49_36	P63	BN63B4	114
38	31	1.3	35	2430		VF 44_35	P63	BN63B4	108
47	26	1.5	28	2270		VF 44_28	P63	BN63B4	108
47	26	2.9	28	2560		VF 49_28	P63	BN63B4	114
55	23	2.7	24	2430		VF 49_24	P63	BN63B4	114
66	19	0.9	20	1040		VF 30_20	P63	BN63B4	106
66	20	1.9	20	2040		VF 44_20	P63	BN63B4	108
73	18	3.2	18	2230		VF 49_18	P63	BN63B4	114
77	16	1.8	35	1970		VF 44_35	P63	BN63A2	108
88	15	1.2	15	960		VF 30_15	P63	BN63B4	106
94	15	2.0	14	1830		VF 44_14	P63	BN63B4	108
132	11	1.5	10	860		VF 30_10	P63	BN63B4	106
132	11	2.7	10	1640		VF 44_10	P63	BN63B4	108
189	8	2.1	7	770		VF 30_7	P63	BN63B4	106
193	7	2.9	14	1470		VF 44_14	P63	BN63A2	108
270	5	2.2	10	710		VF 30_10	P63	BN63A2	106
386	4	3.1	7	640		VF 30_7	P63	BN63A2	106

0.25 kW

n ₂ min-1	M ₂ Nm	S	i	R _{n2} N	 IE1	 IEC	 IE1		
0.28	1358	1.4	3200	13800		WVF 63/130_3200	P71	BN71B6	141
0.28	1868	2.4	3200	19500		WVF 86/185_3200	P71	BN71B6	153
0.31	1952	1.4	2944	16000		WVF 86/150_2944	P71	BN71B6	147
0.43	945	1.9	3200	13800		WVF 63/130_3200	P71	BN71A4	141
0.43	1334	3.1	3200	19500		WVF 86/185_3200	P71	BN71A4	153
0.47	1380	1.9	2944	16000		WVF 86/150_2944	P71	BN71A4	147
0.49	1562	2.8	1840	19500		WVF 86/185_1840	P71	BN71B6	153
0.54	1022	1.8	2560	13800		WVF 63/130_2560	P71	BN71A4	141
0.54	1289	3.3	2560	19500		WVF 86/185_2560	P71	BN71A4	153
0.65	1464	1.8	1380	16000		WVF 86/150_1380	P71	BN71B6	147
0.66	1006	1.0	2070	8000		VF/W 49/110_2070	P71	BN71A4	135
0.75	1214	2.1	1840	16000		WVF 86/150_1840	P71	BN71A4	147
0.75	1019	1.8	1200	13800		WVF 63/130_1200	P71	BN71B6	141
0.76	875	2.1	1800	13800		WVF 63/130_1800	P71	BN71A4	141
0.83	863	1.2	1656	8000		VF/W 49/110_1656	P71	BN71A4	135
0.90	845	2.1	1520	13800		WVF 63/130_1520	P71	BN71A4	141
0.98	1049	2.6	920	16000		WVF 86/150_920	P71	BN71B6	147
1.0	1006	2.6	1380	16000		WVF 86/150_1380	P71	BN71A4	147
1.0	703	1.4	1350	8000		VF/W 49/110_1350	P71	BN71A4	135
1.1	708	2.5	1200	13800		WVF 63/130_1200	P71	BN71A4	141
1.2	746	2.5	760	13800		WVF 63/130_760	P71	BN71B6	141
1.3	581	1.7	1080	8000		VF/W 49/110_1080	P71	BN71A4	135
1.3	860	3.1	690	16000		WVF 86/150_690	P71	BN71B6	147
1.4	617	2.9	960	13800		WVF 63/130_960	P71	BN71A4	141
1.7	544	1.9	540	8000		VF/W 49/110_540	P71	BN71B6	135
1.7	543	1.0	525	7000		VF/W 44/86_525	P71	BN71B6	131
1.8	515	3.5	760	13800		WVF 63/130_760	P71	BN71A4	141
1.9	500	2.0	720	8000		VF/W 49/110_720	P71	BN71A4	135
2.0	474	1.1	700	7000		VF/W 44/86_700	P71	BN71A4	131
2.5	384	2.6	540	8000		VF/W 49/110_540	P71	BN71A4	135
2.6	383	1.3	525	7000		VF/W 44/86_525	P71	BN71A4	131
3.0	366	1.1	300	5750		VF/W 44/75_300	P71	BN71B6	127
3.0	382	1.5	300	8000		WR 110_300	P71	BN71B6	134
3.0	374	2.8	300	8000		VF/W 49/110_300	P71	BN71B6	135
3.4	319	1.2	400	5750		VF/W 44/75_400	P71	BN71A4	127
3.4	285	1.8	400	7000		VF/W 44/86_400	P71	BN71A4	131
3.4	313	3.2	400	8000		VF/W 49/110_400	P71	BN71A4	135
3.8	318	1.0	240	7000		WR 86_240	P71	BN71B6	130
3.8	337	1.7	240	8000		WR 110_240	P71	BN71B6	134
3.9	323	1.7	230	7000		VF/W 44/86_230	P71	BN71B6	131
3.9	311	3.4	230	8000		VF/W 49/110_230	P71	BN71B6	135
4.6	255	1.1	300	7000		WR 86_300	P71	BN71A4	130
4.6	266	1.4	300	5750		VF/W 44/75_300	P71	BN71A4	127
4.6	266	2.1	300	8000		WR 110_300	P71	BN71A4	134
4.6	234	2.1	300	7000		VF/W 44/86_300	P71	BN71A4	131
4.7	280	1.4	192	7000		WR 86_192	P71	BN71B6	130



0.25 kW

n ₂ min-1	M ₂ Nm	S	i	R _{n2} N	 IE1			 IEC	 IEC	 IEC		
5.5	247	1.5	250	5750				VF/W 44/75_250	P71	BN71A4	127	
5.7	204	1.1	240	6200				WR 75_240	P71	BN71A4	126	
5.7	221	1.4	240	7000				WR 86_240	P71	BN71A4	130	
5.7	233	2.4	240	8000				WR 110_240	P71	BN71A4	134	
6.0	216	2.3	230	7000				VF/W 44/86_230	P71	BN71A4	131	
6.0	219	1.4	150	6200				WR 75_150	P71	BN71B6	126	
6.7	193	0.9	135	5000				WR 63_135	P71	BN71B6	122	
7.2	193	1.7	192	7000				WR 86_192	P71	BN71A4	130	
7.2	200	3.1	192	8000				WR 110_192	P71	BN71A4	134	
7.6	172	1.4	180	6200				WR 75_180	P71	BN71A4	126	
7.9	175	1.1	114	5000				WR 63_114	P71	BN71B6	122	
8.2	175	2.0	168	7000				WR 86_168	P71	BN71A4	130	
9.0	122	1.0	100	5000	W 63_100	S1	M1SD6	120				
9.0	133	1.2	100	6200	W 75_100	S1	M1SD6	124	W 75_100	P71	BN71B6	125
9.0	146	1.7	100	7000	W 86_100	S1	M1SD6	128	W 86_100	P71	BN71B6	129
9.2	151	1.7	150	6200				WR 75_150	P71	BN71A4	126	
10.0	151	2.7	138	7000				WR 86_138	P71	BN71A4	130	
10.0	160	2.3	90	6200				WR 75_90	P71	BN71B6	126	
10.2	136	1.3	135	5000				WR 63_135	P71	BN71A4	122	
11.3	110	1.1	80	5000	W 63_80	S1	M1SD6	120				
11.3	115	1.7	80	6200	W 75_80	S1	M1SD6	124	W 75_80	P71	BN71B6	125
11.3	125	2.2	80	7000	W 86_80	S1	M1SD6	128	W 86_80	P71	BN71B6	129
11.5	131	2.3	120	6200				WR 75_120	P71	BN71A4	126	
11.5	138	2.8	120	7000				WR 86_120	P71	BN71A4	130	
12.1	121	1.5	114	5000				WR 63_114	P71	BN71A4	122	
13.8	89	1.3	100	5000				W 63_100	P71	BN71A4	122	
13.8	96	1.6	100	6200				W 75_100	P71	BN71A4	125	
13.8	102	2.2	100	7000				W 86_100	P71	BN71A4	129	
15.3	100	1.9	90	5000				WR 63_90	P71	BN71A4	122	
15.3	108	3.0	90	6200				WR 75_90	P71	BN71A4	126	
17.2	78	1.5	80	5000				W 63_80	P71	BN71A4	122	
17.2	82	2.2	80	6200				W 75_80	P71	BN71A4	125	
17.2	89	2.9	80	7000				W 86_80	P71	BN71A4	129	
18.3	95	3.1	75	6200				WR 75_75	P71	BN71A4	126	
19.1	88	2.1	72	5000				WR 63_72	P71	BN71A4	122	
20.0	70	1.0	45	3150								
21.5	68	1.8	64	5000				W 63_64	P71	BN71A4	122	
22.0	63	0.9	60	3150								
22.9	68	3.0	60	6200				W 75_60	P71	BN71A4	125	
24.1	72	2.5	57	4780				WR 63_57	P71	BN71A4	122	
29.3	51	1.3	45	2850								
31	52	2.8	45	4550				W 63_45	P71	BN71A4	122	
31	59	3.0	45	4460				WR 63_45	P71	BN71A4	122	
32	50	1.0	28	2300				VF 44_28	P71	BN71B6	108	
36	46	3.4	38	4320				W 63_38	P71	BN71A4	122	
37	44	1.6	36	2670				VF 49_36	P71	BN71A4	114	
38	43	0.9	35	2300				VF 44_35	P71	BN71A4	108	
38	49	3.3	36	4160				WR 63_36	P71	BN71A4	122	
45	39	1.1	20	2190				VF 44_20	P71	BN71B6	108	
47	36	1.1	28	2190				VF 44_28	P71	BN71A4	108	
47	36	2.1	28	2480				VF 49_28	P71	BN71A4	114	
55	33	1.9	24	2360				VF 49_24	P71	BN71A4	114	
64	29	1.3	14	1980				VF 44_14	P71	BN71B6	108	
64	29	2.5	14	2260				VF 49_14	P71	BN71B6	114	
66	28	1.4	20	1970				VF 44_20	P71	BN71A4	108	
73	25	2.3	18	2170				VF 49_18	P71	BN71A4	114	
77	23	1.3	35	1930				VF 44_35	P63	BN63B2	108	
90	22	1.8	10	1780				VF 44_10	P71	BN71B6	108	
90	22	2.9	10	2040				VF 49_10	P71	BN71B6	114	
94	21	1.4	14	1770				VF 44_14	P71	BN71A4	108	
94	21	3.2	14	2010				VF 49_14	P71	BN71A4	114	
113	17	2.8	24	1930				VF 49_24	P63	BN63B2	114	
129	16	2.5	7	1590				VF 44_7	P71	BN71B6	108	
132	15	1.9	10	1590				VF 44_10	P71	BN71A4	108	
135	14	1.0	20	840				VF 30_20	P63	BN63B2	106	
180	11	1.3	15	780				VF 30_15	P63	BN63B2	106	
189	11	2.7	7	1420				VF 44_7	P71	BN71A4	108	
270	8	1.6	10	690				VF 30_10	P63	BN63B2	106	
270	8	2.9	10	1300				VF 44_10	P63	BN63B2	108	
386	5	2.2	7	620				VF 30_7	P63	BN63B2	106	





0.37 kW



n ₂ min-1	M ₂ Nm	S	i	R _{n2} N	IE1			IE1				
0.28	2734	1.6	3200	19500				W/VF 86/185_3200	P80	BN80A6	153	
0.31	2858	0.9	2944	16000				W/VF 86/150_2944	P80	BN80A6	147	
0.36	2684	1.6	2560	19500				W/VF 86/185_2560	P80	BN80A6	153	
0.43	1403	1.3	3200	13800				W/VF 63/130_3200	P71	BN71B4	141	
0.43	1981	2.1	3200	19500				W/VF 86/185_3200	P71	BN71B4	153	
0.47	2050	1.3	2944	16000				W/VF 86/150_2944	P71	BN71B4	147	
0.54	1519	1.2	2560	13800				W/VF 63/130_2560	P71	BN71B4	141	
0.54	1915	2.2	2560	19500				W/VF 86/185_2560	P71	BN71B4	153	
0.60	1771	1.0	1520	13800				W/VF 63/130_1520	P80	BN80A6	141	
0.66	2143	1.3	1380	16000				W/VF 86/150_1380	P80	BN80A6	147	
0.74	1803	1.4	1840	16000				W/VF 86/150_1840	P71	BN71B4	147	
0.74	1614	2.6	1840	19500				W/VF 86/185_1840	P71	BN71B4	153	
0.76	1300	1.4	1800	13800				W/VF 63/130_1800	P71	BN71B4	141	
0.86	1444	2.9	1600	19500				W/VF 86/185_1600	P71	BN71B4	153	
0.90	1255	1.4	1520	13800				W/VF 63/130_1520	P71	BN71B4	141	
0.99	1357	3.2	920	19500				W/VF 86/185_920	P80	BN80A6	153	
1.0	1495	1.7	1380	16000				W/VF 86/150_1380	P71	BN71B4	147	
1.0	1045	1.0	1350	8000				VF/W 49/110_1350	P71	BN71B4	135	
1.1	1052	1.7	1200	13800				W/VF 63/130_1200	P71	BN71B4	141	
1.3	864	1.2	1080	8000				VF/W 49/110_1080	P71	BN71B4	135	
1.3	1259	2.1	690	16000				W/VF 86/150_690	P80	BN80A6	147	
1.4	916	2.0	960	13800				W/VF 63/130_960	P71	BN71B4	141	
1.5	1068	2.4	920	16000				W/VF 86/150_920	P71	BN71B4	147	
1.7	797	1.3	540	8000				VF/W 49/110_540	P80	BN80A6	135	
1.7	1068	2.5	529	16000				W/VF 86/150_529	P80	BN80A6	147	
1.8	764	2.4	760	13800				W/VF 63/130_760	P71	BN71B4	141	
1.9	743	1.3	720	8000				VF/W 49/110_720	P71	BN71B4	135	
2.0	890	2.9	690	16000				W/VF 86/150_690	P71	BN71B4	147	
2.3	619	2.9	600	13800				W/VF 63/130_600	P71	BN71B4	141	
2.5	571	1.8	540	8000				VF/W 49/110_540	P71	BN71B4	135	
2.6	750	3.5	529	16000				W/VF 86/150_529	P71	BN71B4	147	
3.0	559	1.0	300	8000				WR 110_300	P80	BN80A6	134	
3.0	571	1.8	300	13800				VFR 130_300	P80	BN80A6	138	
3.0	547	1.9	300	8000				VF/W 49/110_300	P80	BN80A6	135	
3.4	423	1.2	400	7000				VF/W 44/86_400	P71	BN71B4	131	
3.4	464	2.2	400	8000				VF/W 49/110_400	P71	BN71B4	135	
3.8	494	1.2	240	8000				WR 110_240	P80	BN80A6	134	
3.8	503	2.4	240	13800				VFR 130_240	P80	BN80A6	138	
4.0	455	2.3	230	8000				VF/W 49/110_230	P80	BN80A6	135	
4.6	395	1.4	300	8000				WR 110_300	P71	BN71B4	134	
4.6	348	1.4	300	7000				VF/W 44/86_300	P71	BN71B4	131	
4.6	371	2.7	300	8000				VF/W 49/110_300	P71	BN71B4	135	
4.7	410	1.0	192	7000				WR 86_192	P80	BN80A6	130	
4.7	425	1.6	192	8000				WR 110_192	P80	BN80A6	134	
4.7	432	3.0	192	13800				VFR 130_192	P80	BN80A6	138	
5.4	372	1.0	168	7000				WR 86_168	P80	BN80A6	130	
5.4	391	2.0	168	8000				WR 110_168	P80	BN80A6	134	
5.4	391	3.4	168	13800				VFR 130_168	P80	BN80A6	138	
5.7	328	0.9	240	7000				WR 86_240	P71	BN71B4	130	
5.7	347	1.6	240	8000				WR 110_240	P71	BN71B4	134	
6.0	320	1.6	230	7000				VF/W 44/86_230	P71	BN71B4	131	
6.0	308	3.2	230	8000				VF/W 49/110_230	P71	BN71B4	135	
6.1	320	1.0	150	6200				WR 75_150	P80	BN80A6	126	
6.6	327	1.3	138	7000				WR 86_138	P80	BN80A6	130	
6.6	338	2.4	138	8000				WR 110_138	P80	BN80A6	134	
7.1	287	1.1	192	7000				WR 86_192	P71	BN71B4	130	
7.1	297	2.1	192	8000				WR 110_192	P71	BN71B4	134	
7.6	294	1.5	120	7000				WR 86_120	P80	BN80A6	130	
7.6	303	2.9	120	8000				WR 110_120	P80	BN80A6	134	
7.6	255	0.9	180	6200				WR 75_180	P71	BN71B4	126	
8.2	260	1.4	168	7000				WR 86_168	P71	BN71B4	130	
8.2	273	2.6	168	8000				WR 110_168	P71	BN71B4	134	
9.1	214	1.2	100	7000	W 86_100	S1	M1LA6	128	W 86_100	P80	BN80A6	129
9.1	224	1.2	150	6200					WR 75_150	P71	BN71B4	126
9.9	224	1.8	138	7000					WR 86_138	P71	BN71B4	130
9.9	235	3.0	138	8000					WR 110_138	P71	BN71B4	134
10.1	234	1.6	90	6200					WR 75_90	P80	BN80A6	126
11.4	168	1.2	80	6200	W 75_80	S1	M1LA6	124	W 75_80	P80	BN80A6	125
11.4	183	1.5	80	7000	W 86_80	S1	M1LA6	128	W 86_80	P80	BN80A6	129



0.37 kW



n ₂ min-1	M ₂ Nm	S	i	R _{n2} N	 IE1			 IEC	 IE1			
					W	S	M		WR	P	BN	
11.4	195	1.6	120	6200				WR 75_120	P71	BN71B4	126	
11.4	204	1.9	120	7000				WR 86_120	P71	BN71B4	130	
12.0	179	1.0	114	5000				WR 63_114	P71	BN71B4	122	
12.1	204	1.6	75	6200				WR 75_75	P80	BN80A6	126	
13.2	196	2.0	69	7000				WR 86_69	P80	BN80A6	130	
13.7	142	1.1	100	6200	W 75_100	S1	M1SD4	124	W 75_100	P71	BN71B4	125
13.7	152	1.5	100	7000	W 86_100	S1	M1SD4	128	W 86_100	P71	BN71B4	129
14.2	139	1.0	64	5000	W 63_64	S1	M1LA6	120	W 63_64	P80	BN80A6	122
15.2	140	1.5	60	6200	W 75_60	S1	M1LA6	124	W 75_60	P80	BN80A6	125
15.2	149	1.3	90	5000				WR 63_90	P71	BN71B4	122	
15.2	160	2.0	90	6200				WR 75_90	P71	BN71B4	126	
15.2	156	2.8	90	7000				WR 86_90	P71	BN71B4	130	
16.3	144	2.3	56	7000	W 86_56	S1	M1LA6	128	W 86_56	P80	BN80A6	129
17.1	116	1.0	80	5000	W 63_80	S1	M1SD4	120	W 63_80	P71	BN71B4	122
17.1	122	1.5	80	6200	W 75_80	S1	M1SD4	124	W 75_80	P71	BN71B4	125
17.1	132	1.9	80	7000	W 86_80	S1	M1SD4	128	W 86_80	P71	BN71B4	129
18.3	141	2.1	75	6200				WR 75_75	P71	BN71B4	126	
19.0	130	1.4	72	4830				WR 63_72	P71	BN71B4	122	
19.9	133	2.8	69	7000				WR 86_69	P71	BN71B4	130	
20.2	136	2.6	45	6200				WR 75_45	P80	BN80A6	126	
21.4	101	1.2	64	4870	W 63_64	S1	M1SD4	120	W 63_64	P71	BN71B4	122
21.4	112	2.5	64	7000	W 86_64	S1	M1SD4	128	W 86_64	P71	BN71B4	129
22.8	101	2.0	60	6200	W 75_60	S1	M1SD4	124	W 75_60	P71	BN71B4	125
22.8	119	2.5	60	6200				WR 75_60	P71	BN71B4	126	
22.8	119	3.2	60	7000				WR 86_60	P71	BN71B4	130	
24.0	107	1.7	57	4540				WR 63_57	P71	BN71B4	122	
24.5	101	3.0	56	7000	W 86_56	S1	M1SD4	128	W 86_56	P71	BN71B4	129
27.4	88	2.5	50	6200	W 75_50	S1	M1SD4	124	W 75_50	P71	BN71B4	125
30	73	0.9	45	2680				VF 49_45	P71	BN71B4	114	
30	78	1.9	45	4400	W 63_45	S1	M1SD4	120	W 63_45	P71	BN71B4	122
30	88	2.0	45	4250				WR 63_45	P71	BN71B4	122	
30	93	3.2	45	5880				WR 75_45	P71	BN71B4	126	
34	74	3.4	40	5820	W 75_40	S1	M1SD4	124	W 75_40	P71	BN71B4	125
36	69	2.3	38	4180	W 63_38	S1	M1SD4	120	W 63_38	P71	BN71B4	122
38	62	1.1	36	2530				VF 49_36	P71	BN71B4	114	
38	73	2.2	36	3980				WR 63_36	P71	BN71B4	122	
46	57	2.8	30	3900	W 63_30	S1	M1SD4	120	W 63_30	P71	BN71B4	122
49	51	1.4	28	2360				VF 49_28	P71	BN71B4	114	
57	46	1.4	24	2250				VF 49_24	P71	BN71B4	114	
57	48	3.2	24	3650	W 63_24	S1	M1SD4	120	W 63_24	P71	BN71B4	122
65	42	1.7	14	1940				VF 49_14	P80	BN80A6	114	
69	40	1.0	20	1870				VF 44_20	P71	BN71B4	108	
72	40	3.8	19	3400	W 63_19	S1	M1SD4	120	W 63_19	P71	BN71B4	122
76	36	1.6	18	2080				VF 49_18	P71	BN71B4	114	
79	33	0.9	35	1860				VF 44_35	P71	BN71A2	108	
91	32	2.0	10	1930				VF 49_10	P80	BN80A6	114	
98	29	1.0	14	1690				VF 44_14	P71	BN71B4	108	
98	29	2.2	14	1940				VF 49_14	P71	BN71B4	114	
117	24	2.0	24	1880				VF 49_24	P71	BN71A2	114	
137	22	1.3	10	1520				VF 44_10	P71	BN71B4	108	
137	22	2.7	10	1750				VF 49_10	P71	BN71B4	114	
138	21	1.4	20	1570				VF 44_20	P71	BN71A2	108	
153	19	2.3	18	1720				VF 49_18	P71	BN71A2	114	
196	16	1.9	7	1360				VF 44_7	P71	BN71B4	108	
196	16	3.5	7	1570				VF 49_7	P71	BN71B4	114	
275	11	2.0	10	1260				VF 44_10	P71	BN71A2	108	
393	8	2.8	7	1120				VF 44_7	P71	BN71A2	108	

0.55 kW

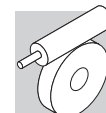
n ₂ min-1	M ₂ Nm	S	i	R _{n2} N	 IE1			 IEC	 IE1		
					W	S	M		W	P	BN
0.29	4019	1.1	3200	19500				W/VF 86/185_3200	P80	BN80B6	153
0.36	3946	1.1	2560	19500				W/VF 86/185_2560	P80	BN80B6	153
0.43	2902	1.4	3200	19500				W/VF 86/185_3200	P80	BN80A4	153
0.47	3004	0.9	2944	16000				W/VF 86/150_2944	P80	BN80A4	147



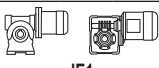



0.55 kW





n ₂ min-1	M ₂ Nm	S	i	R _{n2} N	 IE1			 IE1				
0.50	3362	1.3	1840	19500			W/VF 86/185_1840	P80	BN80B6	153		
0.54	2805	1.5	2560	19500			W/VF 86/185_2560	P80	BN80A4	153		
0.76	2642	1.0	1840	16000			W/VF 86/150_1840	P80	BN80A4	147		
0.76	2364	1.8	1840	19500			W/VF 86/185_1840	P80	BN80A4	153		
0.77	1905	0.9	1800	13800			W/VF 63/130_1800	P80	BN80A4	141		
0.87	2116	2.0	1600	19500			W/VF 86/185_1600	P80	BN80A4	153		
0.91	1838	1.0	1520	13800			W/VF 63/130_1520	P80	BN80A4	141		
1.0	1996	2.2	920	19500			W/VF 86/185_920	P80	BN80B6	153		
1.0	2190	1.2	1380	16000			W/VF 86/150_1380	P80	BN80A4	147		
1.2	1542	1.2	1200	13800			W/VF 63/130_1200	P80	BN80A4	141		
1.2	1542	2.7	1200	19500			W/VF 86/185_1200	P80	BN80A4	153		
1.3	1852	1.5	690	16000			W/VF 86/150_690	P80	BN80B6	147		
1.4	1342	1.3	960	13800			W/VF 63/130_960	P80	BN80A4	141		
1.5	1564	1.7	920	16000			W/VF 86/150_920	P80	BN80A4	147		
1.5	1460	2.9	920	19500			W/VF 86/185_920	P80	BN80A4	153		
1.5	1473	3.0	600	19500			W/VF 86/185_600	P80	BN80B6	153		
1.7	1300	3.2	800	19500			W/VF 86/185_800	P80	BN80A4	153		
1.7	1570	1.7	529	16000			W/VF 86/150_529	P80	BN80B6	147		
1.8	1120	1.6	760	13800			W/VF 63/130_760	P80	BN80A4	141		
2.0	1304	2.0	690	16000			W/VF 86/150_690	P80	BN80A4	147		
2.3	1028	1.0	400	8000			VF/W 49/110_400	P80	BN80B6	135		
2.3	907	2.0	600	13800			W/VF 63/130_600	P80	BN80A4	141		
2.6	837	1.2	540	8000			VF/W 49/110_540	P80	BN80A4	135		
2.6	1099	2.4	529	16000			W/VF 86/150_529	P80	BN80A4	147		
3.0	956	2.7	460	16000			W/VF 86/150_460	P80	BN80A4	147		
3.1	839	1.2	300	13800			VFR 130_300	P80	BN80B6	138		
3.1	805	1.3	300	8000			VF/W 49/110_300	P80	BN80B6	135		
3.5	680	1.5	400	8000			VF/W 49/110_400	P80	BN80A4	135		
3.5	665	2.7	400	13800			W/VF 63/130_400	P80	BN80A4	141		
3.8	740	1.6	240	13800			VFR 130_240	P80	BN80B6	138		
4.0	670	1.6	230	8000			VF/W 49/110_230	P80	BN80B6	135		
4.0	756	3.4	345	16000			W/VF 86/150_345	P80	BN80A4	147		
4.6	578	0.9	300	8000			WR 110_300	P80	BN80A4	134		
4.6	601	1.5	300	13800			VFR 130_300	P80	BN80A4	138		
4.6	544	1.8	300	8000			VF/W 49/110_300	P80	BN80A4	135		
4.8	625	1.1	192	8000			WR 110_192	P80	BN80B6	134		
5.0	529	3.4	280	13800			W/VF 63/130_280	P80	BN80A4	141		
5.8	508	1.1	240	8000			WR 110_240	P80	BN80A4	134		
5.8	517	2.2	240	13800			VFR 130_240	P80	BN80A4	138		
6.0	452	2.2	230	8000			VF/W 49/110_230	P80	BN80A4	135		
6.7	504	3.0	138	13800			VFR 130_138	P80	BN80B6	138		
7.2	435	1.4	192	8000			WR 110_192	P80	BN80A4	134		
7.2	443	2.7	192	13800			VFR 130_192	P80	BN80A4	138		
7.7	432	1.0	120	7000			WR 86_120	P80	BN80B6	130		
8.3	381	0.9	168	7000			WR 86_168	P80	BN80A4	130		
8.3	400	1.8	168	8000			WR 110_168	P80	BN80A4	134		
8.3	406	3.0	168	13800			VFR 130_168	P80	BN80A4	138		
9.2	325	1.5	100	8000	W 110_100	S2	M2SA6	132	W 110_100	P80	BN80B6	133
10.1	329	1.2	138	7000			WR 86_138	P80	BN80A4	130		
10.1	344	2.1	138	8000			WR 110_138	P80	BN80A4	134		
10.2	344	1.1	90	6200			WR 75_90	P80	BN80B6	126		
11.5	269	1.0	80	7000	W 86_80	S2	M2SA6	128	W 86_80	P80	BN80B6	129
11.6	286	1.1	120	6200			WR 75_120	P80	BN80A4	126		
11.6	299	1.3	120	7000			WR 86_120	P80	BN80A4	130		
11.6	308	2.6	120	8000			WR 110_120	P80	BN80A4	134		
12.3	300	1.1	75	6200			WR 75_75	P80	BN80B6	126		
13.3	288	1.4	69	7000			WR 86_69	P80	BN80B6	130		
13.3	295	2.5	69	8000			WR 110_69	P80	BN80B6	134		
13.8	225	1.0	100	7000	W 86_100	S1	M1LA4	128	W 86_100	P80	BN80A4	129
15.4	235	1.4	90	6200			WR 75_90	P80	BN80A4	126		
15.4	228	1.9	90	7000			WR 86_90	P80	BN80A4	130		
15.4	238	3.5	90	8000			WR 110_90	P80	BN80A4	134		
16.4	211	1.5	56	7000	W 86_56	S2	M2SA6	128	W 86_56	P80	BN80B6	129
17.3	180	1.0	80	6200	W 75_80	S1	M1LA4	124	W 75_80	P80	BN80A4	125
17.3	195	1.3	80	7000	W 86_80	S1	M1LA4	128	W 86_80	P80	BN80A4	129
18.5	207	1.4	75	6200			WR 75_75	P80	BN80A4	126		
20.1	196	1.9	69	7000			WR 86_69	P80	BN80A4	130		
20.1	201	3.2	69	8000			WR 110_69	P80	BN80A4	134		
20.4	162	1.0	45	4540	W 63_45	S2	M2SA6	120	W 63_45	P80	BN80B6	122
21.6	166	1.7	64	7000	W 86_64	S1	M1LA4	128	W 86_64	P80	BN80A4	129
23.0	148	1.3	60	6200	W 75_60	S1	M1LA4	124	W 75_60	P80	BN80A4	125
23.0	162	2.2	40	7000	W 86_40	S2	M2SA6	128	W 86_40	P80	BN80B6	129
23.2	175	1.7	60	6040			WR 75_60	P80	BN80A4	126		
23.2	175	2.2	60	7000			WR 86_60	P80	BN80A4	130		
24.2	143	1.2	38	4340	W 63_38	S2	M2SA6	120	W 63_38	P80	BN80B6	122
24.6	149	2.0	56	7000	W 86_56	S1	M1LA4	128	W 86_56	P80	BN80A4	129



0.55 kW





n ₂ min-1	M ₂ Nm	S	i	R _{n2} N	 IE1				 IEC			
					W 75_50	S1	M1LA4		W 75_50	P80	BN80A4	
27.6	129	1.7	50	5960	W 75_50	S1	M1LA4	124	W 75_50	P80	BN80A4	125
30	128	2.7	46	7000	W 86_46	S1	M1LA4	128	W 86_46	P80	BN80A4	129
31	115	1.3	45	4140	W 63_45	S1	M1LA4	120	W 63_45	P80	BN80A4	122
31	136	2.2	45	5580					WR 75_45	P80	BN80A4	126
31	133	2.9	45	7000					WR 86_45	P80	BN80A4	130
35	110	2.3	40	5610	W 75_40	S1	M1LA4	124	W 75_40	P80	BN80A4	125
35	114	2.9	40	7000	W 86_40	S1	M1LA4	128	W 86_40	P80	BN80A4	129
36	101	1.5	38	3950	W 63_38	S1	M1LA4	120	W 63_38	P80	BN80A4	122
40	105	3.3	23	7000	W 86_23	S2	M2SA6	128	W 86_23	P80	BN80B6	129
46	84	1.9	30	3700	W 63_30	S1	M1LA4	120	W 63_30	P80	BN80A4	122
46	88	3.1	30	5150	W 75_30	S1	M1LA4	124	W 75_30	P80	BN80A4	125
46	95	2.9	30	4950					WR 75_30	P80	BN80A4	126
49	76	1.0	28	2170					VF 49_28	P80	BN80A4	114
55	76	3.3	25	4880	W 75_25	S1	M1LA4	124	W 75_25	P80	BN80A4	125
58	69	0.9	24	2080					VF 49_24	P80	BN80A4	114
58	71	2.2	24	3480	W 63_24	S1	M1LA4	120	W 63_24	P80	BN80A4	122
66	62	1.1	14	1960					VF 49_14	P80	BN80B6	114
73	59	2.6	19	3260	W 63_19	S1	M1LA4	120	W 63_19	P80	BN80A4	122
77	53	1.1	18	1930					VF 49_18	P80	BN80A4	114
92	47	1.4	10	1800					VF 49_10	P80	BN80B6	114
92	47	3.2	15	3050	W 63_15	S1	M1LA4	120	W 63_15	P80	BN80A4	122
99	43	1.5	14	1810					VF 49_14	P80	BN80A4	114
115	39	3.6	12	2850	W 63_12	S1	M1LA4	120	W 63_12	P80	BN80A4	122
117	35	1.3	24	1800					VF 49_24	P71	BN71B2	114
131	35	3.7	7	2700	W 63_7	S2	M2SA6	120	W 63_7	P80	BN80B6	122
138	32	1.8	10	1650					VF 49_10	P80	BN80A4	114
141	30	1.0	20	1490					VF 44_20	P71	BN71B2	108
156	28	1.6	18	1650					VF 49_18	P71	BN71B2	114
197	23	2.4	7	1480					VF 49_7	P80	BN80A4	114
281	16	1.4	10	1210					VF 44_10	P71	BN71B2	108
281	16	2.7	10	1390					VF 49_10	P71	BN71B2	114
401	12	1.9	7	1080					VF 44_7	P71	BN71B2	108

0.75 kW

n ₂ min-1	M ₂ Nm	S	i	R _{n2} N	 IE2				 IEC			
					VF/VF 130/210_3200	P90	BE90S6		VF/VF 130/210_3200	P90	BE90S6	
0.29	4867	1.3	3200	34500					VF/VF 130/210_3200	P90	BE90S6	158
0.29	4623	1.9	3200	52000					VF/VF 130/250_3200	P90	BE90S6	164
0.37	4672	1.4	2560	34500					VF/VF 130/210_2560	P90	BE90S6	158
0.37	4478	2.0	2560	52000					VF/VF 130/250_2560	P90	BE90S6	164
0.45	3852	1.1	3200	19500					W /VF 86/185_3200	P80	BE80B4	153
0.51	4478	1.0	1840	19500					W /VF 86/185_1840	P90	BE90S6	153
0.51	3918	1.6	1840	34500					VF/VF 130/210_1840	P90	BE90S6	158
0.51	4058	2.3	1840	52000					VF/VF 130/250_1840	P90	BE90S6	164
0.56	3724	1.1	2560	19500					W /VF 86/185_2560	P80	BE80B4	153
0.78	3138	1.3	1840	19500					W /VF 86/185_1840	P80	BE80B4	153
0.90	2809	1.5	1600	19500					W /VF 86/185_1600	P80	BE80B4	153
1.0	2659	1.6	920	19500					W /VF 86/185_920	P90	BE90S6	153
1.2	2046	0.9	1200	13800					W /VF 63/130_1200	P80	BE80B4	141
1.2	2046	2.0	1200	19500					W /VF 86/185_1200	P80	BE80B4	153
1.4	2466	1.1	690	16000					W /VF 86/150_690	P90	BE90S6	147
1.5	1781	1.0	960	13800					W /VF 63/130_960	P80	BE80B4	141
1.5	2076	1.2	920	16000					W /VF 86/150_920	P80	BE80B4	147
1.5	1938	2.1	920	19500					W /VF 86/185_920	P80	BE80B4	153
1.8	2092	1.3	529	16000					W /VF 86/150_529	P90	BE90S6	147
1.8	1725	2.4	800	19500					W /VF 86/185_800	P80	BE80B4	153
1.8	1486	1.2	760	13800					W /VF 63/130_760	P80	BE80B4	141
2.0	1730	1.5	690	16000					W /VF 86/150_690	P80	BE80B4	147
2.3	1204	1.5	600	13800					W /VF 63/130_600	P80	BE80B4	141
2.3	1354	3.1	600	19500					W /VF 86/185_600	P80	BE80B4	153
2.7	1460	1.7	529	16000					W /VF 86/150_529	P80	BE80B4	147
3.1	1269	2.0	460	16000					W /VF 86/150_460	P80	BE80B4	147
3.1	1140	1.2	300	16000					VFR 150_300	P90	BE90S6	144
3.1	1141	2.1	300	19500					VFR 185_300	P90	BE90S6	150
3.6	903	1.1	400	8000					VF/W 49/110_400	P80	BE80B4	135
3.6	882	2.0	400	13800					W /VF 63/130_400	P80	BE80B4	141
3.9	986	1.2	240	13800					VFR 130_240	P90	BE90S6	138
3.9	986	1.7	240	16000					VFR 150_240	P90	BE90S6	144
3.9	986	2.9	240	19500					VFR 185_240	P90	BE90S6	150

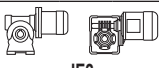





0.75 kW





n ₂ min-1	M ₂ Nm	S	i	R _{n2} N	 IE2				 IE2			
4.2	1004	2.6	345	16000					W /VF 86/150_345	P80	BE80B4	147
4.8	797	1.1	300	13800					VFR 130_300	P80	BE80B4	138
4.8	723	1.4	300	8000					VF/W 49/110_300	P80	BE80B4	135
4.8	873	3.0	300	16000					W /VF 86/150_300	P80	BE80B4	147
4.9	862	2.3	192	16000					VFR 150_192	P90	BE90S6	144
5.1	702	2.6	280	13800					W /VF 63/130_280	P80	BE80B4	141
5.6	767	1.0	168	8000					WR 110_168	P90	BE90S6	134
5.6	661	1.2	168	16000					VFR 150_168	P90	BE90S6	144
5.9	394	1.9	240	13800					VFR 130_240	P80	BE80B4	138
6.2	267	1.3	230	8000					VF/W 49/110_230	P80	BE80B4	135
6.8	661	1.2	138	8000					WR 110_138	P90	BE90S6	134
6.8	672	2.3	138	13800					VFR 130_138	P90	BE90S6	138
7.4	577	1.1	192	8000					WR 110_192	P80	BE80B4	134
7.5	587	2.0	192	13800					VFR 130_192	P80	BE80B4	138
8.5	530	1.3	168	8000					WR 110_168	P80	BE80B4	134
8.5	539	2.2	168	13800					VFR 130_168	P80	BE80B4	138
9.4	434	1.1	100	8000	W110_100	S3	ME3SA6	132	W 110_100	P90	BE90S6	133
9.4	448	1.7	100	13200					VF 130_100	P90	BE90S6	136
10.4	436	0.9	138	7000					WR 86_138	P80	BE80B4	130
10.4	455	1.6	138	8000					WR 110_138	P80	BE80B4	134
10.3	464	3.0	138	13800					VFR 130_138	P80	BE80B4	138
11.8	372	1.4	80	8000	W110_80	S3	ME3SA6	132	W 110_80	P90	BE90S6	133
11.8	390	2.5	80	13200					VF 130_80	P90	BE90S6	136
12.0	397	1.0	120	7000					WR 86_120	P80	BE80B4	130
12.0	409	1.9	120	8000					WR 110_120	P80	BE80B4	134
12.0	403	3.5	120	13800					VFR 130_120	P80	BE80B4	138
13.6	394	1.9	69	8000					WR 110_69	P90	BE90S6	134
14.3	311	1.5	100	8000	W110_100	S2	ME2SB4	132	W 110_100	P80	BE80B4	133
14.7	307	1.0	64	7000	W86_64	S3	ME3SA6	128	W 86_64	P90	BE90S6	129
14.7	331	3.2	64	13200					VF 130_64	P90	BE90S6	136
15.9	312	1.0	90	6200					WR 75_90	P80	BE80B4	126
15.9	302	1.5	90	7000					WR 86_90	P80	BE80B4	130
15.9	316	2.6	90	8000					WR 110_90	P80	BE80B4	134
16.8	281	1.2	56	7000	W86_56	S3	ME3SA6	128	W 86_56	P90	BE90S6	129
16.8	289	2.2	56	8000	W110_56	S3	ME3SA6	132	W 110_56	P90	BE90S6	133
17.9	257	1.0	80	7000	W86_80	S2	ME2SB4	128	W 86_80	P80	BE80B4	129
17.9	265	1.8	80	8000	W110_80	S2	ME2SB4	132	W 110_80	P80	BE80B4	133
18.8	239	1.0	50	6200	W75_50	S3	ME3SA6	124	W 75_50	P90	BE90S6	125
19.1	275	1.1	75	5980					WR 75_75	P80	BE80B4	126
20.7	260	1.5	69	7000					WR 86_69	P80	BE80B4	130
20.7	267	2.4	69	8000					WR 110_69	P80	BE80B4	134
20.9	267	1.3	45	6010					WR 75_45	P90	BE90S6	126
22.4	219	1.3	64	7000	W86_64	S2	ME2SB4	128	W 86_64	P80	BE80B4	129
22.4	225	2.4	64	8000	W110_64	S2	ME2SB4	132	W 110_64	P80	BE80B4	133
23.5	207	1.3	40	5930	W75_40	S3	ME3SA6	124	W 75_40	P90	BE90S6	125
23.8	196	1.0	60	5960	W75_60	S2	ME2SB4	124	W 75_60	P80	BE80B4	125
23.8	231	1.3	60	5640					WR 75_60	P80	BE80B4	126
23.8	231	1.6	60	7000					WR 86_60	P80	BE80B4	130
23.8	238	2.8	60	8000					WR 110_60	P80	BE80B4	134
25.5	197	1.5	56	7000	W86_56	S2	ME2SB4	128	W 86_56	P80	BE80B4	129
25.5	202	3.0	56	8000	W110_56	S2	ME2SB4	132	W 110_56	P80	BE80B4	133
28.6	171	1.3	50	5670	W75_50	S2	ME2SB4	124	W 75_50	P80	BE80B4	125
30.6	169	2.0	46	7000	W86_46	S2	ME2SB4	128	W 86_46	P80	BE80B4	129
30.6	171	3.5	46	8000	W110_46	S2	ME2SB4	132	W 110_46	P80	BE80B4	133
32	151	1.0	45	3860	W63_45	S2	ME2SB4	120	W 63_45	P80	BE80B4	122
32	180	1.6	45	5250					WR 75_45	P80	BE80B4	126
32	176	2.2	45	7000					WR 86_45	P80	BE80B4	130
36	144	1.8	40	5370	W75_40	S2	ME2SB4	124	W 75_40	P80	BE80B4	125
36	150	2.2	40	7000	W86_40	S2	ME2SB4	128	W 86_40	P80	BE80B4	129
38	133	1.2	38	3700	W63_38	S2	ME2SB4	120	W 63_38	P80	BE80B4	122
41	140	2.5	23	7000	W86_23	S3	ME3SA6	128	W 86_23	P90	BE90S6	129
48	112	1.4	30	3490	W63_30	S2	ME2SB4	120	W 63_30	P80	BE80B4	122
48	126	2.2	30	4680					WR 75_30	P80	BE80B4	126
48	116	2.3	30	4950	W75_30	S2	ME2SB4	124	W 75_30	P80	BE80B4	125
48	115	3.3	30	7000	W86_30	S2	ME2SB4	128	W 86_30	P80	BE80B4	129
57	100	2.5	25	4700	W75_25	S2	ME2SB4	124	W 75_25	P80	BE80B4	125
60	94	1.7	24	3290	W63_24	S2	ME2SB4	120	W 63_24	P80	BE80B4	122
62	94	3.4	23	7000	W86_23	S2	ME2SB4	128	W 86_23	P80	BE80B4	129
72	83	3.0	20	4400	W75_20	S2	ME2SB4	124	W 75_20	P80	BE80B4	125
75	77	1.9	19	3100	W63_19	S2	ME2SB4	120	W 63_19	P80	BE80B4	122
95	63	2.4	15	2910	W63_15	S2	ME2SB4	120	W 63_15	P80	BE80B4	122
102	57	1.1	14	1690					VF 49_14	P80	BE80B4	114



0.75 kW

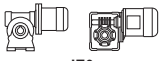

n ₂ min-1	M ₂ Nm	S	i	R _{n2} N	 IE2				 IE2			
119	47	1.0	24	1710								
119	51	2.7	12	2740	W63_12	S2	ME2SB4	120	VF 49_24	P80	BE80A2	114
134	46	2.8	7	2590					W 63_12	P80	BE80B4	122
143	42	1.4	10	1540					W 63_7	P90	BE90S6	122
143	43	3.3	10	2600	W63_10	S2	ME2SB4	120	VF 49_10	P80	BE80B4	114
190	32	3.9	15	2440	W 63_15	S2	ME2SA2	120	W 63_10	P80	BE80B4	122
204	30	1.8	7	1400					W 63_15	P80	BE80A2	122
204	31	3.9	7	2340	W63_7	S2	ME2SB4	120	VF 49_7	P80	BE80B4	114
285	21	2.1	10	1340					W 63_7	P80	BE80B4	122
407	15.5	2.7	7	1200					VF 49_10	P80	BE80A2	114
									VF 49_7	P80	BE80A2	114

1.1 kW

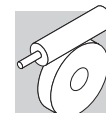
n ₂ min-1	M ₂ Nm	S	i	R _{n2} N	 IE2				 IE2			
0.30	7126	0.9	3200	34500					VF/VF 130/210_3200	P100	BE100M6	158
0.30	6769	1.3	3200	52000					VF/VF 130/250_3200	P100	BE100M6	164
0.37	6841	0.9	2560	34500					VF/VF 130/210_2560	P100	BE100M6	158
0.37	6555	1.4	2560	52000					VF/VF 130/250_2560	P100	BE100M6	164
0.45	5213	1.2	3200	34500					VF/VF 130/210_3200	P90	BE90S4	158
0.45	4975	1.8	3200	52000					VF/VF 130/250_3200	P90	BE90S4	164
0.51	6965	0.9	1840	34500					VF/VF 130/210_1840	P100	BE100M6	158
0.51	5941	1.5	1840	52000					VF/VF 130/250_1840	P100	BE100M6	164
0.56	4549	1.4	2560	34500					VF/VF 130/210_2560	P90	BE90S4	158
0.56	4738	1.9	2560	52000					VF/VF 130/250_2560	P90	BE90S4	164
0.78	4631	0.9	1840	19500					W /VF 86/185_1840	P90	BE90S4	153
0.78	4768	1.3	1840	34500					VF/VF 130/210_1840	P90	BE90S4	158
0.78	4223	2.1	1840	52000					VF/VF 130/250_1840	P90	BE90S4	164
0.90	4146	1.0	1600	19500					W /VF 86/185_1600	P90	BE90S4	153
1.0	3892	1.1	920	19500					W /VF 86/185_920	P100	BE100M6	153
1.2	3020	1.4	1200	19500					W /VF 86/185_1200	P90	BE90S4	153
1.5	2860	1.4	920	19500					W /VF 86/185_920	P90	BE90S4	153
1.8	2547	1.6	800	19500					W /VF 86/185_800	P90	BE90S4	153
2.0	2554	1.0	690	16000					W /VF 86/150_690	P90	BE90S4	147
2.3	1777	1.0	600	13800					W /VF 63/130_600	P90	BE90S4	141
2.3	1999	2.1	600	19500					W /VF 86/185_600	P90	BE90S4	153
2.7	2154	1.2	529	16000					W /VF 86/150_529	P90	BE90S4	147
3.1	1873	1.4	460	16000					W /VF 86/150_460	P90	BE90S4	147
3.2	1670	1.4	300	19500					VFR 185_300	P100	BE100M6	150
3.6	1303	1.4	400	13800					W /VF 63/130_400	P90	BE90S4	141
3.6	1422	2.9	400	19500					W /VF 86/185_400	P90	BE90S4	153
3.9	1443	1.1	240	16000					VFR 150_240	P100	BE100M6	144
3.9	1443	1.9	240	19500					VFR 185_240	P100	BE100M6	150
4.2	1481	1.7	345	16000					W /VF 86/150_345	P90	BE90S4	147
4.8	1206	1.1	300	16000					VFR 150_300	P90	BE90S4	144
4.8	1221	1.9	300	19500					VFR 185_300	P90	BE90S4	150
4.8	1289	2.0	300	16000					W /VF 86/150_300	P90	BE90S4	147
4.9	1240	1.0	192	13800					VFR 130_192	P100	BE100M6	138
5.1	1037	1.7	280	13800					W /VF 63/130_280	P90	BE90S4	141
5.9	1012	1.1	240	13800					VFR 130_240	P90	BE90S4	138
5.9	1030	1.5	240	16000					VFR 150_240	P90	BE90S4	144
5.9	1049	2.6	240	19500					VFR 185_240	P90	BE90S4	150
6.3	1050	2.4	225	16000					W /VF 86/150_225	P90	BE90S4	147
6.8	983	1.5	138	13800					VFR 130_138	P100	BE100M6	138
6.8	983	2.3	138	16000					VFR 150_138	P100	BE100M6	144
7.2	947	2.7	200	16000					W /VF 86/150_200	P90	BE90S4	147
7.5	867	1.4	192	13800					VFR 130_192	P90	BE90S4	138
7.5	881	1.9	192	16000					VFR 150_192	P90	BE90S4	144
7.9	869	1.0	120	8000					WR 110_120	P100	BE100M6	134
8.0	866	3.4	180	19500					VFR 185_180	P90	BE90S4	150
8.5	796	1.5	168	13800					VFR 130_168	P90	BE90S4	138
8.5	808	2.1	168	16000					VFR 150_168	P90	BE90S4	144
9.5	657	1.2	100	13200					VF 130_100	P100	BE100M6	136

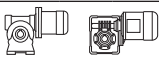

1.1 kW

n ₂ min-1	M ₂ Nm	S	i	R _{n2} N	 IE2			 IEC				
					W	S	ME					
10.3	674	1.1	138	8000				WR 110_138	P90	BE90S4	134	
10.3	685	1.9	138	13800				VFR 130_138	P90	BE90S4	138	
10.3	695	2.8	138	16000				VFR 150_138	P90	BE90S4	144	
10.5	661	1.4	90	8000				WR 110_90	P100	BE100M6	134	
11.8	570	1.6	80	13200				VF 130_80	P100	BE100M6	136	
12.0	604	1.3	120	8000				WR 110_120	P90	BE90S4	134	
12.0	595	2.3	120	13800				VFR 130_120	P90	BE90S4	138	
12.0	604	3.3	120	16000				VFR 150_120	P90	BE90S4	144	
14.3	459	1.0	100	8000	W110_100	S3	ME3SA4	132	W 110_100	P90	BE90S4	133
14.3	518	1.1	100	12600				VF 130_100	P90	BE90S4	136	
15.9	467	1.8	90	8000				WR 110_90	P90	BE90S4	134	
15.9	473	3.1	90	13800				VFR 130_90	P90	BE90S4	138	
17.9	391	1.2	80	8000	W110_80	S3	ME3SA4	132	W 110_80	P90	BE90S4	133
17.9	403	2.2	80	12600				VF 130_80	P90	BE90S4	136	
20.5	353	1.0	46	7000	W86_46	S3	ME3LA6	128	W 86_46	P100	BE100M6	129
20.5	373	3.1	46	13200				VF 130_46	P100	BE100M6	136	
20.7	383	1.0	69	7000				WR 86_69	P90	BE90S4	130	
20.7	394	1.6	69	8000				WR 110_69	P90	BE90S4	134	
20.7	388	3.3	69	13800				VFR 130_69	P90	BE90S4	138	
22.4	332	1.6	64	8000	W110_64	S3	ME3SA4	132	W 110_64	P90	BE90S4	133
22.4	336	2.7	64	12600				VF 130_64	P90	BE90S4	136	
23.6	316	1.1	40	7000	W86_40	S3	ME3LA6	128	W 86_40	P100	BE100M6	129
23.8	342	1.1	60	7000				WR 86_60	P90	BE90S4	130	
23.8	351	1.9	60	8000				WR 110_60	P90	BE90S4	134	
25.5	290	1.0	56	7000	W86_56	S3	ME3SA4	128	W 86_56	P90	BE90S4	129
25.5	299	2.0	56	8000	W110_56	S3	ME3SA4	132	W 110_56	P90	BE90S4	133
25.5	303	3.1	56	12600				VF 130_56	P90	BE90S4	136	
31	249	1.4	46	7000	W86_46	S3	ME3SA4	128	W 86_46	P90	BE90S4	129
31	252	2.4	46	8000	W110_46	S3	ME3SA4	132	W 110_46	P90	BE90S4	133
32	266	1.1	45	5010				WR 75_45	P90	BE90S4	126	
32	259	1.5	45	7000				WR 86_45	P90	BE90S4	130	
32	266	2.7	45	8000				WR 110_45	P90	BE90S4	134	
36	213	1.2	40	4980	W75_40	S3	ME3SA4	124	W 75_40	P90	BE90S4	125
36	222	1.5	40	7000	W86_40	S3	ME3SA4	128	W 86_40	P90	BE90S4	129
36	225	3.0	40	8000	W110_40	S3	ME3SA4	132	W 110_40	P90	BE90S4	133
38	214	1.3	38	4790				WR 75_37.5	P90	BE90S4	126	
41	205	1.6	23	7000	W86_23	S3	ME3LA6	128	W 86_23	P100	BE100M6	129
41	204	1.7	35	7000				WR 86_34.5	P90	BE90S4	130	
48	165	1.0	30	3130				W 63_30	P90	BE90S4	122	
48	186	1.5	30	4530				WR 75_30	P90	BE90S4	126	
48	171	1.6	30	4640	W75_30	S3	ME3SA4	124	W 75_30	P90	BE90S4	125
48	183	1.9	30	7000				WR 86_30	P90	BE90S4	130	
48	169	2.2	30	7000	W86_30	S3	ME3SA4	128	W 86_30	P90	BE90S4	129
57	148	1.7	25	4420	W75_25	S3	ME3SA4	124	W 75_25	P90	BE90S4	125
59	138	1.1	24	2990				W 63_24	P90	BE90S4	122	
62	140	2.3	23	7000	W86_23	S3	ME3SA4	128	W 86_23	P90	BE90S4	129
72	123	2.0	20	4160	W75_20	S3	ME3SA4	124	W 75_20	P90	BE90S4	125
72	124	2.6	20	7000	W86_20	S3	ME3SA4	128	W 86_20	P90	BE90S4	129
76	113	1.3	19	2840				W 63_19	P90	BE90S4	122	
95	92	1.6	15	2690				W 63_15	P90	BE90S4	122	
95	95	2.6	15	3850	W75_15	S3	ME3SA4	124	W 75_15	P90	BE90S4	125
95	95	3.4	15	6820	W86_15	S3	ME3SA4	128	W 86_15	P90	BE90S4	129
119	75	1.9	12	2550				W 63_12	P90	BE90S4	122	
143	64	2.2	10	2440				W 63_10	P90	BE90S4	122	
143	65	3.5	10	3420	W75_10	S3	ME3SA4	124	W 75_10	P90	BE90S4	125
189	47	2.6	15	2330	W63_15	S2	ME2SB2	120	W 63_15	P90	BE90B2	122
204	45	2.6	7	2210				W 63_7	P90	BE90S4	122	
236	38	3.3	12	2190	W63_12	S2	ME2SB2	120	W 63_12	P90	BE90B2	122
283	32	3.9	10	2080	W63_10	S2	ME2SB2	120	W 63_10	P90	BE90B2	122







1.5 kW

n ₂ min-1	M ₂ Nm	S	i	R _{n2} N	IE2		IE2			
0.30	9240	1.0	3200	52000			VF/VF 130/250_3200	P100	BE100LA6	164
0.37	8948	1.0	2560	52000			VF/VF 130/250_2560	P100	BE100LA6	164
0.45	7012	0.9	3200	34500			VF/VF 130/210_3200	P90	BE90LA4	158
0.45	6693	1.3	3200	52000			VF/VF 130/250_3200	P90	BE90LA4	164
0.51	8109	1.1	1840	52000			VF/VF 130/250_1840	P100	BE100LA6	164
0.56	6120	1.0	2560	34500			VF/VF 130/210_2560	P90	BE90LA4	158
0.56	6375	1.4	2560	52000			VF/VF 130/250_2560	P90	BE90LA4	164
0.78	6415	1.0	1840	34500			VF/VF 130/210_1840	P90	BE90LA4	158
0.78	5681	1.6	1840	52000			VF/VF 130/250_1840	P90	BE90LA4	164
1.0	4893	1.3	920	34500			VF/VF 130/210_920	P100	BE100LA6	158
1.0	4893	1.9	920	52000			VF/VF 130/250_920	P100	BE100LA6	164
1.2	4064	1.0	1200	19500			W /VF 86/185_1200	P90	BE90LA4	153
1.2	4620	1.4	800	34500			VF/VF 130/210_800	P100	BE100LA6	158
1.2	4863	1.9	800	52000			VF/VF 130/250_800	P100	BE100LA6	164
1.5	3849	1.1	920	19500			W /VF 86/185_920	P90	BE90LA4	153
1.6	3921	1.7	600	34500			VF/VF 130/210_600	P100	BE100LA6	158
1.6	3921	2.3	600	52000			VF/VF 130/250_600	P100	BE100LA6	164
1.8	3426	1.2	800	19500			W /VF 86/185_800	P90	BE90LA4	153
2.4	2689	1.5	600	19500			W /VF 86/185_600	P90	BE90LA4	153
2.4	2918	2.2	400	34500			VF/VF 130/210_400	P100	BE100LA6	158
2.4	2857	3.2	400	52000			VF/VF 130/250_400	P100	BE100LA6	164
2.7	2898	0.9	529	16000			W /VF 86/150_529	P90	BE90LA4	147
3.1	2520	1.0	460	16000			W /VF 86/150_460	P90	BE90LA4	147
3.2	2280	1.0	300	19500			VFR 185_300	P100	BE100LA6	150
3.2	2234	1.6	300	34500			VFR 210_300	P100	BE100LA6	156
3.2	2370	2.2	300	52000			VFR 250_300	P100	BE100LA6	162
3.4	2128	3.0	280	34500			VF/VF 130/210_280	P100	BE100LA6	158
3.5	1753	1.0	400	13800			W /VF 63/130_400	P90	BE90LA4	141
3.5	1913	2.2	400	19500			W /VF 86/185_400	P90	BE90LA4	153
3.9	1969	0.9	240	16000			VFR 150_240	P100	BE100LA6	144
3.9	1969	1.4	240	19500			VFR 185_240	P100	BE100LA6	150
3.9	1969	2.2	240	34500			VFR 210_240	P100	BE100LA6	156
4.2	1993	1.3	345	16000			W /VF 86/150_345	P90	BE90LA4	147
4.8	1643	1.4	300	19500			VFR 185_300	P90	BE90LA4	150
4.8	1733	1.5	300	16000			W /VF 86/150_300	P90	BE90LA4	147
4.9	1721	1.1	192	16000			VFR 150_192	P100	BE100LA6	144
5.1	1394	1.3	280	13800			W /VF 63/130_280	P90	BE90LA4	141
5.1	1450	2.9	280	19500			W /VF 86/185_280	P90	BE90LA4	153
5.3	1641	2.0	180	19500			VFR 185_180	P100	BE100LA6	150
5.3	1477	3.3	180	34500			VFR 210_180	P100	BE100LA6	156
5.6	1532	0.9	168	13800			VFR 130_168	P100	BE100LA6	138
6.0	1386	1.1	240	16000			VFR 150_240	P90	BE90LA4	144
6.0	1411	1.9	240	19500			VFR 185_240	P90	BE90LA4	150
6.4	1412	1.8	225	16000			W /VF 86/150_225	P90	BE90LA4	147
7.2	1275	2.0	200	16000			W /VF 86/150_200	P90	BE90LA4	147
7.4	1167	1.0	192	13800			VFR 130_192	P90	BE90LA4	138
7.4	1185	1.4	192	16000			VFR 150_192	P90	BE90LA4	144
7.9	1166	2.6	180	19500			VFR 185_180	P90	BE90LA4	150
8.5	1071	1.1	168	13800			VFR 130_168	P90	BE90LA4	138
8.5	1087	1.6	168	16000			VFR 150_168	P90	BE90LA4	144
9.5	927	1.2	100	15500			VF 150_100	P100	BE100LA6	142
9.5	942	2.1	100	19500			VF 185_100	P100	BE100LA6	148
9.5	1001	3.3	150	16000			VFR 185_150	P90	BE90LA4	150
10.3	921	1.4	138	13800			VFR 130_138	P90	BE90LA4	138
10.3	934	2.1	138	16000			VFR 150_138	P90	BE90LA4	144
10.5	902	1.0	90	8000			WR 110_90	P100	BE100LA6	134
10.5	998	3.2	90	19500			VFR 185_90	P100	BE100LA6	150
11.8	778	1.2	80	13200			VF 130_80	P100	BE100LA6	136
11.8	790	1.7	80	15500			VF 150_80	P100	BE100LA6	142
11.9	816	1.0	120	8000			WR 110_120	P90	BE90LA4	134
12.0	801	1.7	120	13800			VFR 130_120	P90	BE90LA4	138
12.0	813	2.4	120	16000			VFR 150_120	P90	BE90LA4	144
13.7	787	1.0	69	8000			WR 110_69	P100	BE100LA6	134
13.7	776	1.9	69	13800			VFR 130_69	P100	BE100LA6	138
13.7	776	2.6	69	16000			VFR 150_69	P100	BE100LA6	144

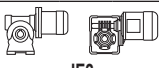



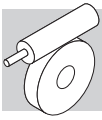

1.5 kW

n ₂ min-1	M ₂ Nm	S	i	R _{n2} N	 IE2			 132	 IEC			 132
					W	S	ME		VF	P	BE	
14.8	671	2.2	64	15500					VF 150_64	P100	BE100LA6	142
15.9	627	1.3	90	8000					WR 110_90	P90	BE90LA4	134
15.9	636	2.3	90	13800					VFR 130_90	P90	BE90LA4	138
15.9	645	3.1	90	16000					VFR 150_90	P90	BE90LA4	144
16.9	578	1.1	56	8000	W110_56	S3	ME3LB6	132	W 110_56	P100	BE100LA6	133
16.9	595	1.8	56	13200					VF 130_56	P100	BE100LA6	136
16.9	604	2.5	56	15500					VF 150_56	P100	BE100LA6	142
17.8	542	1.6	80	12600					VF 130_80	P90	BE90LA4	136
20.5	497	1.3	46	8000	W110_46	S3	ME3LB6	132	W 110_46	P100	BE100LA6	133
20.5	518	3.4	46	15500					VF 150_46	P100	BE100LA6	142
20.7	529	1.2	69	8000					WR 110_69	P90	BE90LA4	134
20.7	523	2.4	69	13800					VFR 130_69	P90	BE90LA4	138
20.7	529	3.5	69	16000					VFR 150_69	P90	BE90LA4	144
22.3	446	1.2	64	8000	W110_64	S3	ME3SB4	132	W 110_64	P90	BE90LA4	133
22.3	453	2.0	64	12600					VF 130_64	P90	BE90LA4	136
23.6	444	2.7	40	13200					VF 130_40	P100	BE100LA6	136
23.8	473	1.4	60	8000					WR 110_60	P90	BE90LA4	134
23.8	466	2.9	60	13800					VFR 130_60	P90	BE90LA4	138
25.6	402	1.5	56	8000	W110_56	S3	ME3SB4	132	W 110_56	P90	BE90LA4	133
25.6	407	2.3	56	12600					VF 130_56	P90	BE90LA4	136
31	334	1.0	46	7000	W86_46	S3	ME3SB4	128	W 86_46	P90	BE90LA4	129
31	339	1.8	46	8000	W110_46	S3	ME3SB4	132	W 110_46	P90	BE90LA4	133
31	348	3.1	46	12600					VF 130_46	P90	BE90LA4	136
32	350	1.1	45	7000					WR 86_45	P90	BE90LA4	130
32	359	2.0	45	8000					WR 110_45	P90	BE90LA4	134
35	299	1.1	40	7000	W86_40	S3	ME3SB4	128	W 86_40	P90	BE90LA4	129
35	303	2.2	40	8000	W110_40	S3	ME3SB4	132	W 110_40	P90	BE90LA4	133
38	292	0.9	25	4330	W75_25	S3	ME3LB6	124	W 75_25	P100	BE100LA6	125
38	287	0.9	38	4330					WR 75_37.5	P90	BE90LA4	126
41	279	1.2	23	7000	W86_23	S3	ME3LB6	128	W 86_23	P100	BE100LA6	129
41	275	1.3	35	7000					WR 86_34.5	P90	BE90LA4	130
48	251	1.1	30	4130					WR 75_30	P90	BE90LA4	126
48	230	1.2	30	4270	W75_30	S3	ME3SB4	124	W 75_30	P90	BE90LA4	125
48	245	1.4	30	7000					WR 86_30	P90	BE90LA4	130
48	227	1.6	30	7000	W86_30	S3	ME3SB4	128	W 86_30	P90	BE90LA4	129
48	230	3.1	30	8000	W110_30	S3	ME3SB4	132	W 110_30	P90	BE90LA4	133
57	199	1.3	25	4100	W75_25	S3	ME3SB4	124	W 75_25	P90	BE90LA4	125
62	188	1.7	23	7000	W86_23	S3	ME3SB4	128	W 86_23	P90	BE90LA4	129
62	190	2.8	23	8000	W110_23	S3	ME3SB4	132	W 110_23	P90	BE90LA4	133
72	166	1.5	20	3880	W75_20	S3	ME3SB4	124	W 75_20	P90	BE90LA4	125
72	168	1.9	20	7000	W86_20	S3	ME3SB4	128	W 86_20	P90	BE90LA4	129
72	168	3.4	20	8000	W110_20	S3	ME3SB4	132	W 110_20	P90	BE90LA4	133
75	153	1.0	19	2550					W 63_19	P90	BE90LA4	122
95	124	1.2	15	2450					W 63_15	P90	BE90LA4	122
95	127	2.0	15	3630	W75_15	S3	ME3SB4	124	W 75_15	P90	BE90LA4	125
95	128	2.4	15	6520					WR 86_15	P90	BE90LA4	130
95	127	2.6	15	6610	W86_15	S3	ME3SB4	128	W 86_15	P90	BE90LA4	129
120	102	1.4	12	2340					W 63_12	P90	BE90LA4	122
135	94	2.2	7	3150	W75_7	S3	ME3LB6	124	W 75_7	P100	BE100LA6	125
143	85	1.6	10	2250					W 63_10	P90	BE90LA4	122
143	87	2.6	10	3250	W75_10	S3	ME3SB4	124	W 75_10	P90	BE90LA4	125
143	87	3.3	10	5850	W86_10	S3	ME3SB4	128	W 86_10	P90	BE90LA4	129
190	65	1.9	15	2200					W 63_15	P90	BE90SA2	122
190	67	3.4	15	3120	W75_15	S3	ME3SA2	124	W 75_15	P90	BE90SA2	125
204	62	1.9	7	2060					W 63_7	P90	BE90LA4	122
204	63	3.1	7	2920	W75_7	S3	ME3SB4	124	W 75_7	P90	BE90LA4	125
204	62	4.0	7	5240	W86_7	S3	ME3SB4	128	W 86_7	P90	BE90LA4	129
238	52	2.4	12	2080					W 63_12	P90	BE90SA2	122
286	44	2.8	10	1980	W63_10	S3	ME3SA2	120	W 63_10	P90	BE90SA2	122



2.2 kW

n ₂ min-1	M ₂ Nm	S	i	R _{n2} N	IE2		IE2			
										
0.45	9879	0.9	3200	52000			VF/VF 130/250_3200	P100	BE100LA4	164
0.56	9408	0.9	2560	52000			VF/VF 130/250_2560	P100	BE100LA4	164
0.78	8385	1.1	1840	52000			VF/VF 130/250_1840	P100	BE100LA4	164
0.89	7527	1.2	1600	52000			VF/VF 130/250_1600	P100	BE100LA4	164
1.0	6884	0.9	920	34500			VF/VF 130/210_920	P112	BE112M6	158
1.0	6884	1.4	920	52000			VF/VF 130/250_920	P112	BE112M6	164
1.2	6174	1.0	1200	34500			VF/VF 130/210_1200	P100	BE100LA4	158
1.2	6174	1.4	1200	52000			VF/VF 130/250_1200	P100	BE100LA4	164
1.5	5004	1.2	920	34500			VF/VF 130/210_920	P100	BE100LA4	158
1.5	5004	1.8	920	52000			VF/VF 130/250_920	P100	BE100LA4	164
1.8	4821	1.3	800	34500			VF/VF 130/210_800	P100	BE100LA4	158
1.8	4940	1.8	800	52000			VF/VF 130/250_800	P100	BE100LA4	164
2.4	3969	1.0	600	19500			W /VF 86/185_600	P100	BE100LA4	153
2.4	3792	1.6	600	34500			VF/VF 130/210_600	P100	BE100LA4	158
2.4	3881	2.3	600	52000			VF/VF 130/250_600	P100	BE100LA4	164
3.2	3143	1.2	300	34500			VFR 210_300	P112	BE112M6	156
3.2	3335	1.6	300	52000			VFR 250_300	P112	BE112M6	162
3.5	2823	1.5	400	19500			W /VF 86/185_400	P100	BE100LA4	153
3.5	2940	2.1	400	34500			VF/VF 130/210_400	P100	BE100LA4	158
3.5	2882	3.1	400	52000			VF/VF 130/250_400	P100	BE100LA4	164
4.0	2771	1.0	240	19500			VFR 185_240	P112	BE112M6	150
4.0	2771	1.6	240	34500			VFR 210_240	P112	BE112M6	156
4.0	2873	2.0	240	52000			VFR 250_240	P112	BE112M6	162
4.8	2426	0.9	300	19500			VFR 185_300	P100	BE100LA4	150
4.8	2426	1.4	300	34500			VFR 210_300	P100	BE100LA4	156
4.8	2514	2.0	300	52000			VFR 250_300	P100	BE100LA4	162
5.1	2141	1.9	280	19500			W /VF 86/185_280	P100	BE100LA4	153
5.1	2141	2.9	280	34500			VF/VF 130/210_280	P100	BE100LA4	158
5.7	2191	0.9	168	16000			VFR 150_168	P112	BE112M6	144
6.0	2082	1.3	240	19500			VFR 185_240	P100	BE100LA4	150
6.0	2082	1.8	240	34500			VFR 210_240	P100	BE100LA4	156
6.0	2152	2.5	240	52000			VFR 250_240	P100	BE100LA4	162
7.4	1750	1.0	192	16000			VFR 150_192	P100	BE100LA4	144
7.9	1720	1.7	180	19500			VFR 185_180	P100	BE100LA4	150
7.9	1694	2.5	180	34500			VFR 210_180	P100	BE100LA4	156
7.9	1773	3.5	180	52000			VFR 250_180	P100	BE100LA4	162
8.0	1616	0.9	120	13800			VFR 130_120	P112	BE112M6	138
8.5	1605	1.1	168	16000			VFR 150_168	P100	BE100LA4	144
9.5	1478	2.2	150	19500			VFR 185_150	P100	BE100LA4	150
9.5	1478	3.0	150	34500			VFR 210_150	P100	BE100LA4	156
9.6	1326	1.5	100	19000			VF 185_100	P112	BE112M6	148
10.3	1360	1.0	138	13800			VFR 130_138	P100	BE100LA4	138
10.3	1379	1.4	138	16000			VFR 150_138	P100	BE100LA4	144
10.6	1404	2.3	90	19500			VFR 185_90	P112	BE112M6	150
10.6	1385	3.3	90	34500			VFR 210_90	P112	BE112M6	156
11.9	1111	1.3	80	15500			VF 150_80	P112	BE112M6	142
11.9	1129	2.1	80	19000			VF 185_80	P112	BE112M6	148
12.0	1182	1.2	120	13800			VFR 130_120	P100	BE100LA4	138
12.0	1200	1.6	120	16000			VFR 150_120	P100	BE100LA4	144
12.0	1235	2.9	120	19500			VFR 185_120	P100	BE100LA4	150
12.0	1235	4.1	120	34500			VFR 210_120	P100	BE100LA4	156
13.8	1091	1.4	69	13800			VFR 130_69	P112	BE112M6	138
13.8	1091	1.9	69	16000			VFR 150_69	P112	BE112M6	144
14.3	956	1.2	100	14700			VF 150_100	P100	BE100LA4	142
14.3	956	2.0	100	18000			VF 185_100	P100	BE100LA4	148
14.9	931	1.2	64	13200			VF 130_64	P112	BE112M6	136
15.9	939	1.6	90	13800			VFR 130_90	P100	BE100LA4	138
15.9	953	2.0	90	16000			VFR 150_90	P100	BE100LA4	144
15.9	911	2.8	60	19000			VF 185_60	P112	BE112M6	148
15.9	1005	2.7	90	19500			VFR 185_90	P100	BE100LA4	150
17.1	838	1.3	56	13200			VF 130_56	P112	BE112M6	136
17.8	800	1.1	80	12600			VF 130_80	P100	BE100LA4	136
17.8	812	1.5	80	14700			VF 150_80	P100	BE100LA4	142



2.2 kW







n ₂ min-1	M ₂ Nm	S	i	R _{n2} N	IE2			IEC	IE2			
17.8	812	2.6	80	18000					VF 185_80	P100	BE100LA4	148
20.7	771	1.7	69	13800					VFR 130_69	P100	BE100LA4	138
20.7	781	2.3	69	16000					VFR 150_69	P100	BE100LA4	144
20.8	718	1.6	46	13200					VF 130_46	P112	BE112M6	136
20.8	728	2.4	46	15500					VF 150_46	P112	BE112M6	142
21.2	762	1.1	45	8000					WR 110_45	P112	BE112M6	134
22.3	668	1.4	64	12600					VF 130_64	P100	BE100LA4	136
22.3	678	1.9	64	14700					VF 150_64	P100	BE100LA4	142
23.8	697	1.0	60	8000					WR 110_60	P100	BE100LA4	134
23.8	688	1.9	60	13800					VFR 130_60	P100	BE100LA4	138
23.8	697	2.7	60	16000					VFR 150_60	P100	BE100LA4	144
23.8	653	3.4	60	18000					VF 185_60	P100	BE100LA4	148
23.9	631	1.2	40	8000					W 110_40	P112	BE112M6	133
25.6	593	1.0	56	8000	W110_56	S3	ME3LA4	132	W 110_56	P100	BE100LA4	133
25.6	601	1.6	56	12600					VF 130_56	P100	BE100LA4	136
25.6	609	2.2	56	14200					VF 150_56	P100	BE100LA4	142
31	500	1.2	46	8000	W110_46	S3	ME3LA4	132	W 110_46	P100	BE100LA4	133
31	514	2.0	46	12600					VF 130_46	P100	BE100LA4	136
31	521	2.9	46	14700					VF 150_46	P100	BE100LA4	142
32	529	1.3	45	8000					WR 110_45	P100	BE100LA4	134
31	543	3.1	45	16000					VFR 150_45	P100	BE100LA4	144
35	447	1.5	40	8000	W110_40	S3	ME3LA4	132	W 110_40	P100	BE100LA4	133
35	447	2.4	40	12600					VF 130_40	P100	BE100LA4	136
35	453	3.4	40	14700					VF 150_40	P100	BE100LA4	142
42	398	2.6	23	13200					VF 130_23	P112	BE112M6	136
48	335	1.1	30	7000	W86_30	S3	ME3LA4	128	W 86_30	P100	BE100LA4	129
48	339	2.1	30	8000	W110_30	S3	ME3LA4	132	W 110_30	P100	BE100LA4	133
48	348	3.0	30	12600					VF 130_30	P100	BE100LA4	136
62	277	1.2	23	6990	W86_23	S3	ME3LA4	128	W 86_23	P100	BE100LA4	129
62	280	1.9	23	8000	W110_23	S3	ME3LA4	132	W 110_23	P100	BE100LA4	133
62	280	3.1	23	12600					VF 130_23	P100	BE100LA4	136
72	244	1.0	20	3410	W75_20	S3	ME3LA4	124	W 75_20	P100	BE100LA4	125
72	247	1.3	20	6730	W86_20	S3	ME3LA4	128	W 86_20	P100	BE100LA4	129
72	247	2.3	20	8000	W110_20	S3	ME3LA4	132	W 110_20	P100	BE100LA4	133
95	187	1.3	15	3240	W75_15	S3	ME3LA4	124	W 75_15	P100	BE100LA4	125
95	187	1.8	15	6270	W86_15	S3	ME3LA4	128	W 86_15	P100	BE100LA4	129
95	185	3.2	15	8000	W110_15	S3	ME3LA4	132	W 110_15	P100	BE100LA4	133
136	133	1.6	7	2780					W 75_7	P112	BE112M6	125
136	133	2.0	7	5540					W 86_7	P112	BE112M6	129
143	129	1.8	10	2940	W75_10	S3	ME3LA4	124	W 75_10	P100	BE100LA4	125
143	129	2.2	10	5590	W86_10	S3	ME3LA4	128	W 86_10	P100	BE100LA4	129
191	98	2.3	15	2920	W75_15	S3	ME3LA2	124	W 75_15	P90	BE90L2	125
191	93	1.3	15	1980					W 63_15	P90	BE90L2	122
204	93	2.1	7	2660	W75_7	S3	ME3LA4	124	W 75_7	P100	BE100LA4	125
204	92	2.7	7	5030	W86_7	S3	ME3LA4	128	W 86_7	P100	BE100LA4	129
239	75	1.6	12	1890					W 63_12	P90	BE90L2	122
287	66	3.0	10	2610	W75_10	S3	ME3LA2	124	W 75_10	P90	BE90L2	125
287	63	1.9	10	1820					W 63_10	P90	BE90L2	122
409	48	3.6	7	2350	W75_7	S3	ME3LA2	124	W 75_7	P90	BE90L2	125
409	46	2.3	7	1660					W 63_7	P90	BE90L2	122

3 kW

n ₂ min-1	M ₂ Nm	S	i	R _{n2} N	IE2			IEC	IE2			
0.90	10403	0.9	1600	52000					VF/VF 130/250_1600	P100	BE100LB4	164
1.0	9813	0.9	920	52000					VF/VF 130/250_920	P132	BE132S6	164
1.2	8534	1.1	1200	52000					VF/VF 130/250_1200	P100	BE100LB4	164
1.5	6917	0.9	920	34500					VF/VF 130/210_920	P100	BE100LB4	158
1.5	6917	1.3	920	52000					VF/VF 130/250_920	P100	BE100LB4	164







3 kW



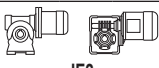

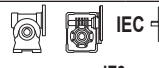
n ₂ min-1	M ₂ Nm	S	i	R _{n2} N	IE2		IEC				
											
1.8	6665	0.9	800	34500			VF/VF 130/210_800	P100	BE100LB4	158	
1.8	6827	1.3	800	52000			VF/VF 130/250_800	P100	BE100LB4	164	
2.5	5242	1.2	600	34500			VF/VF 130/210_600	P100	BE100LB4	158	
2.5	5364	1.7	600	52000			VF/VF 130/250_600	P100	BE100LB4	164	
3.2	4755	1.1	300	52000			VFR 250_300	P132	BE132S6	162	
3.6	3901	1.1	400	19500			W /VF 86/185_400	P100	BE100LB4	153	
3.6	4064	1.6	400	34500			VF/VF 130/210_400	P100	BE100LB4	158	
3.6	3983	2.3	400	52000			VF/VF 130/250_400	P100	BE100LB4	164	
4.0	3950	1.1	240	34500			VFR 210_240	P132	BE132S6	156	
4.0	4096	1.4	240	52000			VFR 250_240	P132	BE132S6	162	
4.8	3353	1.0	300	34500			VFR 210_300	P100	BE100LB4	156	
4.8	3475	1.4	300	52000			VFR 250_300	P100	BE100LB4	162	
5.1	2958	1.4	280	19500			W /VF 86/185_280	P100	BE100LB4	153	
5.1	2958	2.1	280	34500			VF/VF 130/210_280	P100	BE100LB4	158	
5.1	3015	3.0	280	52000			VF/VF 130/250_280	P100	BE100LB4	164	
6.0	2877	1.0	240	19500			VFR 185_240	P100	BE100LB4	150	
6.0	2877	1.4	240	34500			VFR 210_240	P100	BE100LB4	156	
6.0	2975	1.8	240	52000			VFR 250_240	P100	BE100LB4	162	
8.0	2377	1.3	180	19500			VFR 185_180	P100	BE100LB4	150	
8.0	2341	1.8	180	34500			VFR 210_180	P100	BE100LB4	156	
8.0	2450	2.6	180	52000			VFR 250_180	P100	BE100LB4	162	
9.6	2042	1.6	150	19500			VFR 185_150	P100	BE100LB4	150	
9.6	1859	1.6	100	33000			VF 210_100	P132	BE132S6	154	
9.6	2042	2.2	150	34500			VFR 210_150	P100	BE100LB4	156	
9.6	1920	2.5	100	50000			VF 250_100	P132	BE132S6	160	
9.6	2042	3.2	150	52000			VFR 250_150	P100	BE100LB4	162	
10.4	1907	1.0	138	16000			VFR 150_138	P100	BE100LB4	144	
11.9	1609	1.5	80	19000			VF 185_80	P132	BE132S6	148	
11.9	1585	2.1	80	33000			VF 210_80	P132	BE132S6	154	
12.1	1634	0.9	120	13800			VFR 130_120	P100	BE100LB4	138	
12.1	1658	1.2	120	16000			VFR 150_120	P100	BE100LB4	144	
12.1	1707	2.1	120	19500			VFR 185_120	P100	BE100LB4	150	
12.1	1707	2.9	120	34500			VFR 210_120	P100	BE100LB4	156	
12.1	1731	4.0	120	52000			VFR 250_120	P100	BE100LB4	162	
14.4	1321	0.9	100	14700			VF 150_100	P100	BE100LB4	142	
14.4	1321	1.4	100	18000			VF 185_100	P100	BE100LB4	148	
15.9	1298	2.0	60	19000			VF 185_60	P132	BE132S6	148	
15.9	1280	2.9	60	33000			VF 210_60	P132	BE132S6	154	
16.0	1298	1.2	90	13800			VFR 130_90	P100	BE100LB4	138	
16.0	1317	1.5	90	16000			VFR 150_90	P100	BE100LB4	144	
16.0	1390	2.0	90	19500			VFR 185_90	P100	BE100LB4	150	
16.0	1390	2.9	90	34500			VFR 210_90	P100	BE100LB4	156	
18.0	1122	1.1	80	14700			VF 150_80	P100	BE100LB4	142	
18.0	1122	1.9	80	18000			VF 185_80	P100	BE100LB4	148	
20.8	1066	1.2	69	13800			VFR 130_69	P100	BE100LB4	138	
20.8	1080	1.7	69	16000			VFR 150_69	P100	BE100LB4	144	
22.5	923	1.0	64	12600			VF 130_64	P100	BE100LB4	136	
22.5	936	1.4	64	14700			VF 150_64	P100	BE100LB4	142	
24.0	951	1.4	60	13800			VFR 130_60	P100	BE100LB4	138	
24.0	963	2.0	60	16000			VFR 150_60	P100	BE100LB4	144	
24.0	902	2.5	60	18000			VF 185_60	P100	BE100LB4	148	
25.7	831	1.2	56	12600			VF 130_56	P100	BE100LB4	136	
25.7	842	1.6	56	14700			VF 150_56	P100	BE100LB4	142	
28.8	772	3.2	50	18000			VF 185_50	P100	BE100LB4	148	
32	710	1.5	46	12600			VF 130_46	P100	BE100LB4	136	
32	720	2.2	46	14700			VF 150_46	P100	BE100LB4	142	
32	720	1.0	45	8000			WR 110_45	P100	BE100LB4	134	
32	750	2.3	45	16000			VFR 150_45	P100	BE100LB4	144	
36	608	1.1	40	8000	W110_40	S3 ME3LB4	132	W 110_40	P100	BE100LB4	133
36	618	1.8	40	12600			VF 130_40	P100	BE100LB4	136	
36	626	2.5	40	14700			VF 150_40	P100	BE100LB4	142	
42	568	1.0	23	8000			W 110_23	P132	BE132S6	133	
42	568	1.8	23	13200			VF 130_23	P132	BE132S6	136	



3 kW

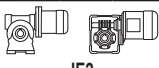

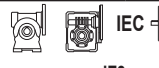

n ₂ min-1	M ₂ Nm	S	i	R _{n2} N	 IE2			 IEC	 IE2			 IEC
					W	S3	ME3LB4		W	P100	BE100LB4	
48	462	1.5	30	8000	W110_30	S3	ME3LB4	132	W 110_30	P100	BE100LB4	133
48	482	2.2	30	12600					VF 130_30	P100	BE100LB4	136
48	488	2.8	30	14700					VF 150_30	P100	BE100LB4	142
48	518	2.9	30	16000					VFR 150_30	P100	BE100LB4	144
62	382	1.4	23	8000	W110_23	S3	ME3LB4	132	W 110_23	P100	BE100LB4	133
62	388	2.3	23	12600					VF 130_23	P100	BE100LB4	136
62	388	3.3	23	14700					VF 150_23	P100	BE100LB4	142
72	336	1.0	20	6240	W86_20	S3	ME3LB4	128	W 86_20	P100	BE100LB4	129
72	336	1.7	20	8000	W110_20	S3	ME3LB4	132	W 110_20	P100	BE100LB4	133
73	341	2.6	20	12600					VF 130_20	P100	BE100LB4	136
96	259	1.0	15	2800	W75_15	S3	ME3LB4	124	W 75_15	P100	BE100LB4	125
96	259	1.3	15	5890	W86_15	S3	ME3LB4	128	W 86_15	P100	BE100LB4	129
96	256	2.4	15	8000	W110_15	S3	ME3LB4	132	W 110_15	P100	BE100LB4	133
96	262	3.5	15	11800					VF 130_15	P100	BE100LB4	136
125	197	3.4	23	11000					VF 130_23	P100	BE100L2	136
144	179	1.3	10	2600	W75_10	S3	ME3LB4	124	W 75_10	P100	BE100LB4	125
144	179	1.6	10	5300	W86_10	S3	ME3LB4	128	W 86_10	P100	BE100LB4	129
144	177	3.1	10	8000	W110_10	S3	ME3LB4	132	W 110_10	P100	BE100LB4	133
192	131	1.7	15	2680	W75_15	S3	ME3LB2	124	W 75_15	P100	BE100L2	125
192	130	2.3	15	5070	W86_15	S3	ME3LB2	128	W 86_15	P100	BE100L2	129
206	128	1.5	7	2380	W75_7	S3	ME3LB4	124	W 75_7	P100	BE100LB4	125
206	127	2.0	7	4780	W86_7	S3	ME3LB4	128	W 86_7	P100	BE100LB4	129
288	90	2.3	10	2430	W75_10	S3	ME3LB2	124	W 75_10	P100	BE100L2	125
288	90	2.9	10	4510	W86_10	S3	ME3LB2	128	W 86_10	P100	BE100L2	129
411	64	2.7	7	2190	W75_7	S3	ME3LB2	124	W 75_7	P100	BE100L2	125
411	64	3.5	7	4040	W86_7	S3	ME3LB2	128	W 86_7	P100	BE100L2	129

4 kW

n ₂ min-1	M ₂ Nm	S	i	R _{n2} N	 IE2			 IEC	 IE2			 IEC
					W	S3	ME3LB4		W	P112	BE112M4	
1.5	9157	1.0	920	52000					VF/VF 130/250_920	P112	BE112M4	164
1.9	9039	1.0	800	52000					VF/VF 130/250_800	P112	BE112M4	164
2.5	6941	0.9	600	34500					VF/VF 130/210_600	P112	BE112M4	158
2.5	7102	1.3	600	52000					VF/VF 130/250_600	P112	BE112M4	164
3.7	5380	1.2	400	34500					VF/VF 130/210_400	P112	BE112M4	158
3.7	5273	1.7	400	52000					VF/VF 130/250_400	P112	BE112M4	164
4.0	5348	1.1	240	52000					VFR 250_240	P132	BE132MA6	162
4.8	4600	1.1	300	52000					VFR 250_300	P112	BE112M4	162
5.2	3917	1.1	280	19500					W /VF 86/185_280	P112	BE112M4	153
5.2	3917	1.6	280	34500					VF/VF 130/210_280	P112	BE112M4	158
5.2	3992	2.3	280	52000					VF/VF 130/250_280	P112	BE112M4	164
5.4	3867	1.3	180	34500					VFR 210_180	P132	BE132MA6	156
5.4	4440	1.5	180	52000					VFR 250_180	P132	BE132MA6	162
6.1	3809	1.0	240	34500					VFR 210_240	P112	BE112M4	156
6.1	3938	1.4	240	52000					VFR 250_240	P112	BE112M4	162
8.1	3147	1.0	180	19500					VFR 185_180	P112	BE112M4	150
8.1	3099	1.4	180	34500					VFR 210_180	P112	BE112M4	156
8.1	3244	1.9	180	52000					VFR 250_180	P112	BE112M4	162
9.7	2427	1.2	100	33000					VF 210_100	P132	BE132MA6	154
9.7	2507	1.9	100	50000					VF 250_100	P132	BE132MA6	160
9.8	2704	1.2	150	19500					VFR 185_150	P112	BE112M4	150
9.8	2704	1.7	150	34500					VFR 210_150	P112	BE112M4	156
9.8	2704	2.4	150	52000					VFR 250_150	P112	BE112M4	162
12.1	2195	0.9	120	16000					VFR 150_120	P112	BE112M4	144
12.1	2260	1.6	120	19500					VFR 185_120	P112	BE112M4	150
12.1	2260	2.2	120	34500					VFR 210_120	P112	BE112M4	156
12.1	2292	3.1	120	52000					VFR 250_120	P112	BE112M4	162
14.6	1749	1.1	100	18000					VF 185_100	P112	BE112M4	148
16.1	1695	1.5	60	19000					VF 185_60	P132	BE132MA6	148
16.1	1671	2.2	60	33000					VF 210_60	P132	BE132MA6	154







4 kW

n ₂ min-1	M ₂ Nm	S	i	R _{n2} N	IE2		IEC			
										
16.1	1719	3.2	60	50000			VF 250_60	P132	BE132MA6	160
16.3	1719	0.9	90	13800			VFR 130_90	P112	BE112M4	138
16.3	1743	1.1	90	16000			VFR 150_90	P112	BE112M4	144
16.3	1840	1.5	90	19500			VFR 185_90	P112	BE112M4	150
16.3	1840	2.2	90	34500			VFR 210_90	P112	BE112M4	156
16.3	1888	3.2	90	52000			VFR 250_90	P112	BE112M4	162
18.3	1485	1.4	80	18000			VF 185_80	P112	BE112M4	148
21.0	1355	1.3	46	15500			VF 150_46	P132	BE132MA6	142
21.2	1411	0.9	69	13800			VFR 130_69	P112	BE112M4	138
21.2	1429	1.3	69	16000			VFR 150_69	P112	BE112M4	144
21.4	1433	3.4	45	34500			VFR 210_45	P132	BE132MA6	156
22.8	1240	1.1	64	14700			VF 150_64	P112	BE112M4	142
24.1	1162	1.0	40	13200			VF 130_40	P132	BE132MA6	136
24.1	1193	3.6	40	33000			VF 210_40	P132	BE132MA6	154
24.4	1259	1.1	60	13800			VFR 130_60	P112	BE112M4	138
24.4	1275	1.5	60	16000			VFR 150_60	P112	BE112M4	144
24.4	1194	1.9	60	18000			VF 185_60	P112	BE112M4	148
24.4	1307	2.5	60	19500			VFR 185_60	P112	BE112M4	150
24.4	1291	3.6	60	34500			VFR 210_60	P112	BE112M4	156
26.1	1100	0.9	56	12500			VF 130_56	P112	BE112M4	136
26.1	1115	1.2	56	14700			VF 150_56	P112	BE112M4	142
29.2	1022	2.4	50	18000			VF 185_50	P112	BE112M4	148
32	940	1.1	46	12600			VF 130_46	P112	BE112M4	136
32	953	1.6	46	14700			VF 150_46	P112	BE112M4	142
32	967	2.5	30	19000			VF 185_30	P132	BE132MA6	148
32	955	3.5	30	33000			VF 210_30	P132	BE132MA6	154
33	993	1.7	45	16000			VFR 150_45	P112	BE112M4	144
33	1017	2.8	45	19500			VFR 185_45	P112	BE112M4	150
36	762	0.9	80	12600			VF 130_80	P112	BE112M2	136
37	818	1.3	40	12600			VF 130_40	P112	BE112M4	136
37	829	1.9	40	14700			VF 150_40	P112	BE112M4	142
42	741	1.4	23	13200			VF 130_23	P132	BE132MA6	136
42	750	2.0	23	13200			VF 150_23	P132	BE132MA6	142
45	635	1.1	64	12600			VF 130_64	P112	BE112M2	136
48	624	1.1	30	8000			W 110_30	P112	BE112M4	133
48	638	1.6	30	12600			VF 130_30	P112	BE112M4	136
48	646	2.1	30	14700			VF 150_30	P112	BE112M4	142
48	686	2.2	30	16000			VFR 150_30	P112	BE112M4	144
63	515	1.0	23	8000			W 110_23	P112	BE112M4	133
63	480	1.6	46	12600			VF 130_46	P112	BE112M2	136
64	514	1.7	23	12600			VF 130_23	P112	BE112M4	136
64	514	2.5	23	14700			VF 150_23	P112	BE112M4	142
72	454	1.3	20	8000			W 110_20	P112	BE112M4	133
73	452	2.0	20	12400			VF 130_20	P112	BE112M4	136
96	344	1.0	15	5410			W 86_15	P112	BE112M4	129
96	340	1.8	15	8000			W 110_15	P112	BE112M4	133
97	346	3.4	10	12700			VF 150_10	P132	BE132MA6	142
98	347	2.7	15	11400			VF 130_15	P112	BE112M4	136
144	238	1.0	10	2160			W 75_10	P112	BE112M4	125
144	238	1.2	10	4940			W 86_10	P112	BE112M4	129
144	235	2.3	10	7840			W 110_10	P112	BE112M4	133
146	237	3.3	10	10100			VF 130_10	P112	BE112M4	136
193	174	1.3	15	2400			W 75_15	P112	BE112M2	125
193	172	1.7	15	4820			W 86_15	P112	BE112M2	129
206	173	1.1	7	1900			W 75_7	P112	BE112M4	125
206	171	1.5	7	4490			W 86_7	P112	BE112M4	129
206	171	3.0	7	7040			W 110_7	P112	BE112M4	133
290	119	1.7	10	2210			W 75_10	P112	BE112M2	125
290	119	2.2	10	4320			W 86_10	P112	BE112M2	129
414	84	2.0	7	2010			W 75_7	P112	BE112M2	125
414	84	2.7	7	3890			W 86_7	P112	BE112M2	129







5.5 kW





n ₂ min-1	M ₂ Nm	S	i	R _{n2} N	 		 				
					IE2	IE3	IE2	IE3	IEC	IEC	
2.4	9630	0.9	600	52000			VF/VF 130/250_600	P132 BE132S4	VF/VF 130/250_600	P132 BX132S4	164
3.4	7714	1.2	280	52000			VF/VF 130/250_280	P160 BE160MA6			164
3.7	7295	0.9	400	34500			VF/VF 130/210_400	P132 BE132S4	VF/VF 130/210_400	P132 BX132S4	158
3.7	7149	1.3	400	52000			VF/VF 130/250_400	P132 BE132S4	VF/VF 130/250_400	P132 BX132S4	164
5.2	5311	1.2	280	34500			VF/VF 130/210_280	P132 BE132S4	VF/VF 130/210_280	P132 BX132S4	158
5.2	5413	1.7	280	52000			VF/VF 130/250_280	P132 BE132S4	VF/VF 130/250_280	P132 BX132S4	164
5.4	6029	1.1	180	52000			VFR 250_180	P160 BE160MA6			162
6.4	5024	1.0	150	34500			VFR 210_150	P160 BE160MA6			156
6.4	5105	1.3	150	52000			VFR 250_150	P160 BE160MA6			162
8.1	4202	1.0	180	34500			VFR 210_180	P132 BE132S4	VFR 210_180	P132 BX132S4	156
8.1	4399	1.4	180	52000			VFR 250_180	P132 BE132S4	VFR 250_180	P132 BX132S4	162
9.7	3296	0.9	100	33000			VF 210_100	P160 BE160MA6			154
9.7	3666	1.2	150	34500			VFR 210_150	P132 BE132S4	VFR 210_150	P132 BX132S4	156
9.7	3666	1.8	150	52000			VFR 250_150	P132 BE132S4	VFR 250_150	P132 BX132S4	162
12.1	2809	1.1	80	33000			VF 210_80	P160 BE160MA6			154
12.1	2895	1.7	80	50000			VF 250_80	P160 BE160MA6			160
12.2	3064	1.6	120	34500			VFR 210_120	P132 BE132S4	VFR 210_120	P132 BX132S4	156
12.2	3108	2.3	120	52000			VFR 250_120	P132 BE132S4	VFR 250_120	P132 BX132S4	162
14.6	2371	1.1	100	31500			VF 210_100	P132 BE132S4	VF 210_100	P132 BX132S4	154
14.6	2590	1.4	100	19500			VFR 185_100	P132 BE132S4	VFR 185_100	P132 BX132S4	150
14.6	2480	1.5	100	47000			VF 250_100	P132 BE132S4	VF 250_100	P132 BX132S4	160
16.1	2301	1.1	60	19000			VF 185_60	P160 BE160MA6			148
16.1	2268	1.6	60	33000			VF 210_60	P160 BE160MA6			154
16.1	2334	2.4	60	50000			VF 250_60	P160 BE160MA6			160
16.2	2495	1.6	90	34500			VFR 210_90	P132 BE132S4	VFR 210_90	P132 BX132S4	156
16.2	2561	2.3	90	52000			VFR 250_90	P132 BE132S4	VFR 250_90	P132 BX132S4	162
18.3	2013	1.1	80	18000			VF 185_80	P132 BE132S4	VF 185_80	P132 BX132S4	148
18.3	2013	1.4	80	31500			VF 210_80	P132 BE132S4	VF 210_80	P132 BX132S4	154
18.3	2072	1.9	80	47000			VF 250_80	P132 BE132S4	VF 250_80	P132 BX132S4	160
19.5	2106	1.3	75	19500			VFR 185_75	P132 BE132S4	VFR 185_75	P132 BX132S4	150
21.0	1839	0.9	46	15500			VF 150_46	P160 BE160MA6			142
21.4	1945	2.5	45	34500			VFR 210_45	P160 BE160MA6			156
21.4	1993	3.4	45	52000			VFR 250_45	P160 BE160MA6			162
24.1	1599	1.1	40	15500			VF 150_40	P160 BE160MA6			142
24.3	1620	1.4	60	18000			VF 185_60	P132 BE132S4	VF 185_60	P132 BX132S4	148
24.3	1598	1.9	60	31500			VF 210_60	P132 BE132S4	VF 210_60	P132 BX132S4	154
24.3	1751	2.7	60	34500			VFR 210_60	P132 BE132S4	VFR 210_60	P132 BX132S4	156
24.3	1663	2.7	60	47000			VF 250_60	P132 BE132S4	VF 250_60	P132 BX132S4	160
24.3	1773	4.0	60	52000			VFR 250_60	P132 BE132S4	VFR 250_60	P132 BX132S4	162
29.2	1430	1.3	50	15940			VFR 150_50	P132 BE132S4	VFR 150_50	P132 BX132S4	144
29.2	1386	1.8	50	18000			VF 185_50	P132 BE132S4	VF 185_50	P132 BX132S4	148
29.2	1477	2.2	50	19500			VFR 185_50	P132 BE132S4	VFR 185_50	P132 BX132S4	150
29.2	1386	2.4	50	31500			VF 210_50	P132 BE132S4	VF 210_50	P132 BX132S4	154
29.2	1386	3.2	50	47000			VF 250_50	P132 BE132S4	VF 250_50	P132 BX132S4	160
31	1292	1.2	46	14700			VF 150_46	P132 BE132S4	VF 150_46	P132 BX132S4	142
32	1248	1.0	30	13200			VF 130_30	P160 BE160MA6			136
32	1362	3.0	45	34500			VFR 210_45	P132 BE132S4	VFR 210_45	P132 BX132S4	156
37	1109	1.0	40	12600			VF 130_40	P132 BE132S4	VF 130_40	P132 BX132S4	136
37	1123	1.4	40	14700			VF 150_40	P132 BE132S4	VF 150_40	P132 BX132S4	142
37	1138	2.3	40	18000			VF 185_40	P132 BE132S4	VF 185_40	P132 BX132S4	148
37	1138	3.1	40	31500			VF 210_40	P132 BE132S4	VF 210_40	P132 BX132S4	154
39	1101	1.5	38	15400			VFR 150_37.5	P132 BE132S4	VFR 150_37.5	P132 BX132S4	144
39	1149	2.4	38	19500			VFR 185_37.5	P132 BE132S4	VFR 185_37.5	P132 BX132S4	150
42	1006	1.0	23	13000			VF 130_23	P160 BE160MA6			136
42	1019	1.4	23	15300			VF 150_23	P160 BE160MA6			142
49	864	1.2	30	12600			VF 130_30	P132 BE132S4	VF 130_30	P132 BX132S4	136
49	875	1.6	30	14700			VF 150_30	P132 BE132S4	VF 150_30	P132 BX132S4	142
49	908	2.2	30	18000			VF 185_30	P132 BE132S4	VF 185_30	P132 BX132S4	148
49	908	3.4	30	31500			VF 210_30	P132 BE132S4	VF 210_30	P132 BX132S4	154
59	775	1.9	25	13400			VFR 150_25	P132 BE132S4	VFR 150_25	P132 BX132S4	144
59	784	3.3	25	19500			VFR 185_25	P132 BE132S4	VFR 185_25	P132 BX132S4	150
64	673	0.9	15	8000			W 110_15	P160 BE160MA6			133
64	696	1.3	23	12100			VF 130_23	P132 BE132S4	VF 130_23	P132 BX132S4	136
64	696	1.8	23	14000			VF 150_23	P132 BE132S4	VF 150_23	P132 BX132S4	142
73	605	0.9	20	8000			W 110_20	P132 BE132S4	W 110_20	P132 BX132S4	133



5.5 kW





n ₂ min-1	M ₂ Nm	S	i	R _{n2} N	 		 		IEC		
					IE2	IE3	IE2	IE3			
73	613	1.5	20	11700			VF 130_20	P132 BE132S4	VF 130_20	P132 BX132S4	136
73	613	2.1	20	13500			VF 150_20	P132 BE132S4	VF 150_20	P132 BX132S4	142
97	454	1.3	15	8000			W 110_15	P132 BE132S4	W 110_15	P132 BX132S4	133
97	471	2.0	15	12800			VF 130_15	P132 BE132S4	VF 130_15	P132 BX132S4	136
97	476	2.4	15	12400			VF 150_15	P132 BE132S4	VF 150_15	P132 BX132S4	142
127	354	1.9	23	10400			VF 130_23	P132 BE132SA2			136
127	354	2.7	23	11800			VF 150_23	P132 BE132SA2			142
146	313	1.8	10	7330			W 110_10	P132 BE132S4	W 110_10	P132 BX132S4	133
146	321	2.5	10	9680			VF 130_10	P132 BE132S4	VF 130_10	P132 BX132S4	136
146	321	3.3	10	11000			VF 150_10	P132 BE132S4	VF 150_10	P132 BX132S4	142
195	234	2.3	15	7060			W 110_15	P132 BE132SA2			133
209	227	2.2	7	6600			W 110_7	P132 BE132S4	W 110_7	P132 BX132S4	133
209	227	3.3	7	8650			VF 130_7	P132 BE132S4	VF 130_7	P132 BX132S4	136
293	160	3.0	10	6290			W 110_10	P132 BE132SA2			133
293	162	3.6	10	8110			VF 130_10	P132 BE132SA2			136
418	113	4.0	7	5640			W 110_7	P132 BE132SA2			133
418	114	4.9	7	7230			VF 130_7	P132 BE132SA2			136

7.5 kW





n ₂ min-1	M ₂ Nm	S	i	R _{n2} N	 		 		IEC		
					IE2	IE3	IE2	IE3			
3.6	9554	0.9	400	52000			VF/VF 130/250_400	P132 BE132MA4	VF/VF 130/250_400	P132 BX132MA4	164
5.2	7097	0.9	280	34500			VF/VF 130/210_280	P132 BE132MA4	VF/VF 130/210_280	P132 BX132MA4	158
5.2	7233	1.2	280	52000			VF/VF 130/250_280	P132 BE132MA4	VF/VF 130/250_280	P132 BX132MA4	164
6.4	7014	1.0	150	52000			VFR 250_150	P160 BE160MB6			162
8.0	5878	1.0	120	34500			VFR 210_120	P160 BE160MB6			156
8.1	5879	1.1	180	52000			VFR 250_180	P132 BE132MA4	VFR 250_180	P132 BX132MA4	162
9.7	4676	1.0	100	50000			VF 250_100	P160 BE160MB6			160
9.7	4899	1.3	150	52000			VFR 250_150	P132 BE132MA4	VFR 250_150	P132 BX132MA4	162
10.7	4809	0.9	90	34500			VFR 210_90	P160 BE160MB6			156
12.1	3978	1.3	80	50000			VF 250_80	P160 BE160MB6			160
12.1	4094	1.2	120	34500			VFR 210_120	P132 BE132MA4	VFR 210_120	P132 BX132MA4	156
12.1	4153	1.7	120	52000			VFR 250_120	P132 BE132MA4	VFR 250_120	P132 BX132MA4	162
14.6	3461	1.0	100	19500			VFR 185_100	P132 BE132MA4	VFR 185_100	P132 BX132MA4	150
14.6	3314	1.1	100	47000			VF 250_100	P132 BE132MA4	VF 250_100	P132 BX132MA4	160
16.1	3117	1.2	60	33000			VF 210_60	P160 BE160MB6			154
16.2	3334	1.2	90	34500			VFR 210_90	P132 BE132MA4	VFR 210_90	P132 BX132MA4	156
16.2	3422	1.7	90	52000			VFR 250_90	P132 BE132MA4	VFR 250_90	P132 BX132MA4	162
18.2	2691	1.1	80	31500			VF 210_80	P132 BE132MA4	VF 210_80	P132 BX132MA4	154
18.2	2769	1.4	80	47000			VF 250_80	P132 BE132MA4	VF 250_80	P132 BX132MA4	160
19.4	2815	1.0	75	19500			VFR 185_75	P132 BE132MA4	VFR 185_75	P132 BX132MA4	150
21.4	2672	1.8	45	34500			VFR 210_45	P160 BE160MB6			156
21.4	2739	2.5	45	52000			VFR 250_45	P160 BE160MB6			162
24.3	2164	1.0	60	18000			VF 185_60	P132 BE132MA4	VF 185_60	P132 BX132MA4	148
24.3	2135	1.4	60	31500			VF 210_60	P132 BE132MA4	VF 210_60	P132 BX132MA4	154
24.3	2340	2.0	60	31500			VFR 210_60	P132 BE132MA4	VFR 210_60	P132 BX132MA4	156
24.3	2223	2.0	60	47000			VF 250_60	P132 BE132MA4	VF 250_60	P132 BX132MA4	160
24.3	2369	3.0	60	52000			VFR 250_60	P132 BE132MA4	VFR 250_60	P132 BX132MA4	162
29.1	1911	1.0	50	14100			VFR 150_50	P132 BE132MA4	VFR 150_50	P132 BX132MA4	144
29.1	1852	1.3	50	18000			VF 185_50	P132 BE132MA4	VF 185_50	P132 BX132MA4	148
29.1	1974	1.6	50	19500			VFR 185_50	P132 BE132MA4	VFR 185_50	P132 BX132MA4	150
29.1	1852	1.7	50	31500			VF 210_50	P132 BE132MA4	VF 210_50	P132 BX132MA4	154
29.1	1852	2.4	50	47000			VF 250_50	P132 BE132MA4	VF 250_50	P132 BX132MA4	160
31	1727	0.9	46	14700			VF 150_46	P132 BE132MA4	VF 150_46	P132 BX132MA4	142
32	1821	2.2	45	34500			VFR 210_45	P132 BE132MA4	VFR 210_45	P132 BX132MA4	156
32	1842	3.5	45	48800			VFR 250_45	P132 BE132MA4	VFR 250_45	P132 BX132MA4	162
36	1501	1.0	40	14700			VF 150_40	P132 BE132MA4	VF 150_40	P132 BX132MA4	142
36	1521	1.7	40	18000			VF 185_40	P132 BE132MA4	VF 185_40	P132 BX132MA4	148
36	1521	2.3	40	31500			VF 210_40	P132 BE132MA4	VF 210_40	P132 BX132MA4	154
36	1541	3.2	40	47000			VF 250_40	P132 BE132MA4	VF 250_40	P132 BX132MA4	160
38	1471	1.1	38	13200			VFR 150_37.5	P132 BE132MA4	VFR 150_37.5	P132 BX132MA4	144
38	1536	1.8	38	18300			VFR 185_37.5	P132 BE132MA4	VFR 185_37.5	P132 BX132MA4	150
49	1155	0.9	30	11900			VF 130_30	P132 BE132MA4	VF 130_30	P132 BX132MA4	136
49	1170	1.1	30	14200			VF 150_30	P132 BE132MA4	VF 150_30	P132 BX132MA4	142
49	1214	1.6	30	18000			VF 185_30	P132 BE132MA4	VF 185_30	P132 BX132MA4	148
49	1214	2.6	30	31500			VF 210_30	P132 BE132MA4	VF 210_30	P132 BX132MA4	154



7.5 kW

n ₂ min-1	M ₂ Nm	S	i	R _{n2} N	 		 		IEC		
					IE2	IE3	IE2	IE3			
49	1257	3.1	30	33400			VFR 210_30	P132 BE132MA4	VFR 210_30	P132 BX132MA4	156
49	1228	3.3	30	4440			VF 250_30	P132 BE132MA4	VF 250_30	P132 BX132MA4	160
59	1036	1.4	25	11000			VFR 150_25	P132 BE132MA4	VFR 150_25	P132 BX132MA4	144
59	1048	2.4	25	16700			VFR 185_25	P132 BE132MA4	VFR 185_25	P132 BX132MA4	150
64	931	0.9	23	11200			VF 130_23	P132 BE132MA4	VF 130_23	P132 BX132MA4	136
64	931	1.3	23	13200			VF 150_23	P132 BE132MA4	VF 150_23	P132 BX132MA4	142
64	958	2.3	15	16700			VF 185_15	P160 BE160MB6			148
73	819	1.1	20	10800			VF 130_20	P132 BE132MA4	VF 130_20	P132 BX132MA4	136
73	819	1.6	20	12700			VF 150_20	P132 BE132MA4	VF 150_20	P132 BX132MA4	142
97	614	1.0	15	7370			W 110_15	P132 BE132MA4	W 110_15	P132 BX132MA4	133
97	629	1.4	15	10200			VF 130_15	P132 BE132MA4	VF 130_15	P132 BX132MA4	136
97	636	1.8	15	11700			VF 150_15	P132 BE132MA4	VF 150_15	P132 BX132MA4	142
127	479	1.4	23	9900			VF 130_23	P132 BE132SB2			136
127	479	2.0	23	11400			VF 150_23	P132 BE132SB2			142
138	462	2.5	7	10200			VF 150_7	P160 BE160MB6			142
146	424	1.3	10	6720			W 110_10	P132 BE132MA4	W 110_10	P132 BX132MA4	133
146	429	1.8	10	9150			VF 130_10	P132 BE132MA4	VF 130_10	P132 BX132MA4	136
146	429	2.4	10	10500			VF 150_10	P132 BE132MA4	VF 150_10	P132 BX132MA4	142
195	320	1.7	15	6660			W 110_15	P132 BE132SB2			133
208	304	1.6	7	6100			W 110_7	P132 BE132MA4	W 110_7	P132 BX132MA4	133
208	304	2.4	7	8210			VF 130_7	P132 BE132MA4	VF 130_7	P132 BX132MA4	136
208	307	3.3	7	9400			VF 150_7	P132 BE132MA4	VF 150_7	P132 BX132MA4	142
293	215	2.2	10	5980			W 110_10	P132 BE132SB2			133
293	217	2.8	10	7840			VF 130_10	P132 BE132SB2			136
418	153	2.9	7	5380			W 110_7	P132 BE132SB2			133
418	154	3.6	7	7010			VF 130_7	P132 BE132SB2			136

9.2 kW

n ₂ min-1	M ₂ Nm	S	i	R _{n2} N	 		 		IEC		
					IE2	IE3	IE2	IE3			
5.1	9054	1.0	280	52000			VFR/VF 130/250_280	P132 BE132MB4			164
9.7	6132	1.1	150	52000			VFR 250_150	P132 BE132MB4	VFR 250_150	P160 BX160MA4	162
12.1	5198	1.3	120	52000			VFR 250_120	P132 BE132MB4	VFR 250_120	P160 BX160MA4	162
14.5	4149	0.9	100	47000			VF 250_100	P132 BE132MB4	VF 250_100	P160 BX160MA4	160
16.1	4173	1.0	90	34500			VFR 210_90	P132 BE132MB4	VFR 210_90	P160 BX160MA4	156
16.1	4283	1.4	90	52000			VFR 250_90	P132 BE132MB4	VFR 250_90	P160 BX160MA4	162
18.1	3368	0.9	80	31500			VF 210_80	P132 BE132MB4	VF 210_80	P160 BX160MA4	154
18.1	3466	1.1	80	47000			VF 250_80	P132 BE132MB4	VF 250_80	P160 BX160MA4	160
24.2	2672	1.1	60	31500			VF 210_60	P132 BE132MB4	VF 210_60	P160 BX160MA4	154
24.2	2929	1.6	60	34500			VFR 210_60	P132 BE132MB4	VFR 210_60	P160 BX160MA4	156
24.2	2782	1.6	60	47000			VF 250_60	P132 BE132MB4	VF 250_60	P160 BX160MA4	160
24.2	2965	2.4	60	51900			VFR 250_60	P132 BE132MB4	VFR 250_60	P160 BX160MA4	162
29.0	2319	1.1	50	18000			VF 185_50	P132 BE132MB4	VF 185_50	P160 BX160MA4	148
29.0	2471	1.3	50	18600			VFR 185_50	P132 BE132MB4			150
29.0	2319	1.4	50	31500			VF 210_50	P132 BE132MB4	VF 210_50	P160 BX160MA4	154
29.0	2319	1.9	50	47000			VF 250_50	P132 BE132MB4	VF 250_50	P160 BX160MA4	160
32	2279	1.8	45	34500			VFR 210_45	P132 BE132MB4	VFR 210_45	P160 BX160MA4	156
32	2306	2.8	45	48000			VFR 250_45	P132 BE132MB4	VFR 250_45	P160 BX160MA4	162
36	1904	1.4	40	18000			VF 185_40	P132 BE132MB4	VF 185_40	P160 BX160MA4	148
36	1904	1.8	40	31500			VF 210_40	P132 BE132MB4	VF 210_40	P160 BX160MA4	154
36	1928	2.5	40	47000			VF 250_40	P132 BE132MB4	VF 250_40	P160 BX160MA4	160
38	1884	0.9	38	11900			VFR 150_37.5	P132 BE132MB4			144
38	1922	1.5	38	17200			VFR 185_37.5	P132 BE132MB4			150
48	1464	0.9	30	11300			VF 150_30	P132 BE132MB4	VF 150_30	P160 BX160MA4	142
48	1519	1.3	30	17900			VF 185_30	P132 BE132MB4	VF 185_30	P160 BX160MA4	148
48	1519	2.0	30	31500			VF 210_30	P132 BE132MB4	VF 210_30	P160 BX160MA4	154
48	1574	2.4	30	32600			VFR 210_30	P132 BE132MB4	VFR 210_30	P160 BX160MA4	156
48	1538	2.6	30	43900			VF 250_30	P132 BE132MB4	VF 250_30	P160 BX160MA4	160
48	1574	3.8	30	42800			VFR 250_30	P132 BE132MB4	VFR 250_30	P160 BX160MA4	162
58	1297	1.2	25	11200			VFR 150_25	P132 BE132MB4			144
58	1312	2.0	25	15800			VFR 185_25	P132 BE132MB4			150
63	1165	1.1	23	12500			VF 150_23	P132 BE132MB4	VF 150_23	P160 BX160MA4	142
73	1025	0.9	20	10100			VF 130_20	P132 BE132MB4	VF 130_20	P160 BX160MA4	136
73	1025	1.3	20	12100			VF 150_20	P132 BE132MB4			142
73	1037	3.0	20	30400			VF 210_20	P132 BE132MB4	VF 210_20	P160 BX160MA4	154
97	787	1.2	15	9560			VF 130_15	P132 BE132MB4			136
97	796	1.4	15	11200			VF 150_15	P132 BE132MB4	VF 150_15	P160 BX160MA4	142
127	601	1.1	23	9510			VF 130_23	P132 BE132MB2			136

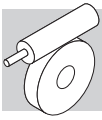

9.2 kW

n ₂ min-1	M ₂ Nm	S	i	R _{n2} N								
					IE2	IE3		IE2	IE3			
127	601	1.6	23	11000				VF 150_23	P132 BE132MB2			142
145	531	1.0	10	6210				W 110_10	P132 BE132MB4			133
145	537	1.5	10	8690				VF 130_10	P132 BE132MB4			136
145	537	2.0	10	16100				VF 150_10	P132 BE132MB4	VF 150_10	P160 BX160MA4	142
195	396	1.4	15	6320				W 110_15	P132 BE132MB2			133
207	380	1.3	7	5670				W 110_7	P132 BE132MB4			133
207	380	1.9	7	7820				VF 130_7	P132 BE132MB4			136
207	384	2.6	7	9030				VF 150_7	P132 BE132MB4	VF 150_7	P160 BX160MA4	142
292	271	1.8	10	5720				W 110_10	P132 BE132MB2			133
292	274	2.2	10	7620				VF 130_10	P132 BE132MB2			136
292	274	2.9	10	8690				VF 150_10	P132 BE132MB2			142
417	192	2.3	7	5170				W 110_7	P132 BE132MB2			133
417	194	2.9	7	6820				VF 130_7	P132 BE132MB2			136

11 kW







n ₂ min-1	M ₂ Nm	S	i	R _{n2} N								
					IE2	IE3		IE2	IE3			
12.3	6130	1.1	120	52000				VFR 250_120	P160 BE160M4	VFR 250_120	P160 BX160MB4	162
16.3	5051	1.2	90	52000				VFR 250_90	P160 BE160M4	VFR 250_90	P160 BX160MB4	162
18.4	4087	0.9	80	47000				VF 250_80	P160 BE160M4	VF 250_80	P160 BX160MB4	160
24.5	3151	0.9	60	31500				VF 210_60	P160 BE160M4	VF 210_60	P160 BX160MB4	154
24.5	3454	1.3	60	34500				VFR 210_60	P160 BE160M4	VFR 210_60	P160 BX160MB4	156
24.5	3281	1.4	60	47000				VF 250_60	P160 BE160M4	VF 250_60	P160 BX160MB4	160
24.5	3496	2.0	60	50900				VFR 250_60	P160 BE160M4	VFR 250_60	P160 BX160MB4	162
29.4	2734	1.2	50	31500				VF 210_50	P160 BE160M4	VF 210_50	P160 BX160MB4	154
29.4	2734	1.6	50	47000				VF 250_50	P160 BE160M4	VF 250_50	P160 BX160MB4	160
33	2688	1.5	45	34500				VFR 210_45	P160 BE160M4	VFR 210_45	P160 BX160MB4	156
33	2720	2.3	45	47100				VFR 250_45	P160 BE160M4	VFR 250_45	P160 BX160MB4	162
37	2245	1.2	40	18500				VF 185_40	P160 BE160M4	VF 185_40	P160 BX160MB4	148
37	2245	1.5	40	31500				VF 210_40	P160 BE160M4	VF 210_40	P160 BX160MB4	154
37	2273	2.1	40	47000				VF 250_40	P160 BE160M4	VF 250_40	P160 BX160MB4	160
49	1791	1.1	30	17200				VF 185_30	P160 BE160M4	VF 185_30	P160 BX160MB4	148
49	1791	1.7	30	31500				VF 210_30	P160 BE160M4	VF 210_30	P160 BX160MB4	154
49	1856	2.0	30	31800				VFR 210_30	P160 BE160M4	VFR 210_30	P160 BX160MB4	156
49	1813	2.2	30	43400				VF 250_30	P160 BE160M4	VF 250_30	P160 BX160MB4	160
49	1856	3.2	30	42100				VFR 250_30	P160 BE160M4	VFR 250_30	P160 BX160MB4	162
74	1209	1.1	20	11400				VF 150_20	P160 BE160M4	VF 150_20	P160 BX160MB4	142
74	1223	1.8	20	15600				VF 185_20	P160 BE160M4	VF 185_20	P160 BX160MB4	148
74	1223	2.5	20	30000				VF 210_20	P160 BE160M4	VF 210_20	P160 BX160MB4	154
98	939	1.2	15	10600				VF 150_15	P160 BE160M4	VF 150_15	P160 BX160MB4	142
98	950	1.9	15	14200				VF 185_15	P160 BE160M4	VF 185_15	P160 BX160MB4	148
98	950	3.0	15	27700				VF 210_15	P160 BE160M4	VF 210_15	P160 BX160MB4	154
147	630	2.7	20	13300				VF 185_20	P160 BE160MA2			148
147	633	1.6	10	9670				VF 150_10	P160 BE160M4	VF 150_10	P160 BX160MB4	142
196	478	2.9	15	12200				VF 185_15	P160 BE160MA2			148
210	454	2.2	7	8660				VF 150_7	P160 BE160M4	VF 150_7	P160 BX160MB4	142
294	323	2.4	10	8440				VF 150_10	P160 BE160MA2			142
420	228	3.3	7	7530				VF 150_7	P160 BE160MA2			142

15 kW







n ₂ min-1	M ₂ Nm	S	i	R _{n2} N								
					IE2	IE3		IE2	IE3			
24.5	4474	1.0	60	47000				VF 250_60	P160 BE160L4	VF 250_60	P160 BX160LA4	160
24.5	4768	1.5	60	48700				VFR 250_60	P160 BE160L4	VFR 250_60	P160 BX160LA4	162
29.4	3728	0.9	50	31500				VF 210_50	P160 BE160L4	VF 210_50	P160 BX160LA4	154
29.4	3728	1.2	50	47000				VF 250_50	P160 BE160L4	VF 250_50	P160 BX160LA4	160
32	3665	1.1	45	33200				VFR 210_45	P160 BE160L4	VFR 210_45	P160 BX160LA4	156
32	3709	1.7	45	45200				VFR 250_45	P160 BE160L4	VFR 250_45	P160 BX160LA4	162
37	3061	0.9	40	16600				VF 185_40	P160 BE160L4	VF 185_40	P160 BX160LA4	148
37	3061	1.1	40	31500				VF 210_40	P160 BE160L4	VF 210_40	P160 BX160LA4	154
37	3100	1.5	40	45900				VF 250_40	P160 BE160L4	VF 250_40	P160 BX160LA4	160
49	2443	1.2	30	31500				VF 210_30	P160 BE160L4	VF 210_30	P160 BX160LA4	154









15 kW

n ₂ min-1	M ₂ Nm	S	i	R _{n2} N	 		 		IEC 		
					IE2	IE3	IE2	IE3			
49	2531	1.5	30	30000			VFR 210_30	P160 BE160L4	VFR 210_30	P160 BX160LA4	156
49	2473	1.6	30	42400			VF 250_30	P160 BE160L4	VF 250_30	P160 BX160LA4	160
49	2531	2.4	30	40600			VFR 250_30	P160 BE160L4	VFR 250_30	P160 BX160LA4	162
74	1668	1.4	20	14300			VF 185_20	P160 BE160L4	VF 185_20	P160 BX160LA4	148
74	1668	1.9	20	29100			VF 210_20	P160 BE160L4	VF 210_20	P160 BX160LA4	154
74	1688	2.6	20	38100			VF 250_20	P160 BE160L4	VF 250_20	P160 BX160LA4	160
98	1280	0.9	15	9360			VF 150_15	P160 BE160L4	VF 150_15	P160 BX160LA4	142
98	1295	1.4	15	13200			VF 185_15	P160 BE160L4	VF 185_15	P160 BX160LA4	148
98	1295	2.2	15	27000			VF 210_15	P160 BE160L4	VF 210_15	P160 BX160LA4	154
98	1295	3.1	15	35100			VF 250_15	P160 BE160L4	VF 250_15	P160 BX160LA4	160
147	855	2.0	20	12700			VF 185_20	P160 BE160MB2	VF 185_20	P160	148
147	863	1.2	10	8720			VF 150_10	P160 BE160L4	VF 150_10	P160 BX160LA4	142
147	873	3.0	10	24000			VF 210_10	P160 BE160L4	VF 210_10	P160 BX160LA4	154
196	649	2.1	15	11600			VF 185_15	P160 BE160MB2	VF 185_15	P160	148
196	649	3.3	15	22700			VF 210_15	P160 BE160MB2	VF 210_15	P160	154
210	618	1.6	7	7840			VF 150_7	P160 BE160L4	VF 150_7	P160 BX160LA4	142
294	437	1.8	10	7960			VF 150_10	P160 BE160MB2	VF 150_10	P160	142
420	309	2.4	7	7120			VF 150_7	P160 BE160MB2	VF 150_7	P160	142

18.5 kW





n ₂ min-1	M ₂ Nm	S	i	R _{n2} N	 		 		IEC 		
					IE2	IE3	IE2	IE3			
29.4	4560	1.0	50	47000			VF 250_50	P180 BE180M4	VF 250_50	P180 BX180M4	160
37	3745	0.9	40	31500			VF 210_40	P180 BE180M4	VF 210_40	P180 BX180M4	154
37	3792	1.3	40	44900			VF 250_40	P180 BE180M4	VF 250_40	P180 BX180M4	160
49	2988	1.0	30	31200			VF 210_30	P180 BE180M4	VF 210_30	P180 BX180M4	154
49	3024	1.3	30	41500			VF 250_30	P180 BE180M4	VF 250_30	P180 BX180M4	160
74	2040	1.1	20	13200			VF 185_20	P180 BE180M4	VF 185_20	P180 BX180M4	148
74	2040	1.5	20	28300			VF 210_20	P180 BE180M4	VF 210_20	P180 BX180M4	154
74	2064	2.1	20	37400			VF 250_20	P180 BE180M4	VF 250_20	P180 BX180M4	160
98	1584	1.2	15	12200			VF 185_15	P180 BE180M4	VF 185_15	P180 BX180M4	148
98	1584	1.8	15	26200			VF 210_15	P180 BE180M4	VF 210_15	P180 BX180M4	154
98	1584	2.5	15	34500			VF 250_15	P180 BE180M4	VF 250_15	P180 BX180M4	160
147	1068	1.7	10	11400			VF 185_10	P180 BE180M4	VF 185_10	P180 BX180M4	148
147	1068	2.5	10	23400			VF 210_10	P180 BE180M4	VF 210_10	P180 BX180M4	154
147	1080	3.4	10	37800			VF 250_10	P180 BE180M4	VF 250_10	P180 BX180M4	160
196	805	1.1	15	8260			VF 150_15	P160 BE160L2	VF 150_15	P160	142
210	756	2.3	7	10100			VF 185_7	P180 BE180M4	VF 185_7	P180 BX180M4	148
210	756	3.0	7	21200			VF 210_7	P180 BE180M4	VF 210_7	P180 BX180M4	154
295	543	1.5	10	7550			VF 150_10	P160 BE160L2	VF 150_10	P160	142
421	384	2.0	7	6760			VF 150_7	P160 BE160L2	VF 150_7	P160	142

22 kW



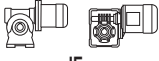

n ₂ min-1	M ₂ Nm	S	i	R _{n2} N	 		 		IEC 		
					IE2	IE3	IE2	IE3			
37	4501	1.1	40	43900			VF 250_40	P180 BE180L4	VF 250_40	P180 BX180L4	160
49	3546	0.9	30	30200			VF 210_30	P180 BE180L4	VF 210_30	P180 BX180L4	154
49	3589	1.1	30	44700			VF 250_30	P180 BE180L4	VF 250_30	P180 BX180L4	160
74	2421	0.9	20	12200			VF 185_20	P180 BE180L4	VF 185_20	P180 BX180L4	148
74	2421	1.3	20	27500			VF 210_20	P180 BE180L4	VF 210_20	P180 BX180L4	154
74	2450	1.8	20	36700			VF 250_20	P180 BE180L4	VF 250_20	P180 BX180L4	160
99	1880	1.0	15	11300			VF 185_15	P180 BE180L4	VF 185_15	P180 BX180L4	148
99	1880	1.5	15	25500			VF 210_15	P180 BE180L4	VF 210_15	P180 BX180L4	154
99	1880	2.1	15	33900			VF 250_15	P180 BE180L4	VF 250_15	P180 BX180L4	160
148	1267	1.4	10	10700			VF 185_10	P180 BE180L4	VF 185_10	P180 BX180L4	148
148	1267	2.1	10	22900			VF 210_10	P180 BE180L4	VF 210_10	P180 BX180L4	154
148	1282	2.9	10	30300			VF 250_10	P180 BE180L4	VF 250_10	P180 BX180L4	160
210	898	1.9	7	9510			VF 185_7	P180 BE180L4	VF 185_7	P180 BX180L4	148
210	898	2.5	7	20800			VF 210_7	P180 BE180L4	VF 210_7	P180 BX180L4	154
210	908	3.5	7	27500			VF 250_7	P180 BE180L4	VF 250_7	P180 BX180L4	160





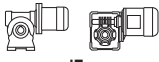

30 kW

n ₂ min-1	M ₂ Nm	S	i	R _{n2} N	 IE...		 IE...	
147	1754	2,1	10	29200	—		VF 250_10 P200 IEC200L4	164
210	1228	1,9	7	19700	—		VF 210_7 P200 IEC200L4	158
210	1242	2,6	7	26600	—		VF 250_7 P200 IEC200L4	164
295	874	2,3	10	19000	—		VF 210_10 P200 IEC200LA2	158
421	619	2,8	7	17200	—		VF 210_7 P200 IEC200LA2	158

37 kW

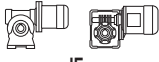
n ₂ min-1	M ₂ Nm	S	i	R _{n2} N	 IE...		 IE...	
74	4107	1,1	20	22800	—		VF 250_20 P225 IEC225S4	164
99	3152	0,9	15	22600	—		VF 210_15 P225 IEC225S4	158
99	3152	1,3	15	31400	—		VF 250_15 P225 IEC225S4	164
148	2125	1,2	10	20500	—		VF 210_10 P225 IEC225S4	158
148	2149	1,7	10	28300	—		VF 250_10 P225 IEC225S4	164
211	1504	1,5	7	18800	—		VF 210_7 P225 IEC225S4	158
211	1521	2,1	7	25800	—		VF 250_7 P225 IEC225S4	164
296	1074	1,9	10	18400	—		VF 210_10 P200 IEC200L2	158
296	1086	2,6	10	24500	—		VF 250_10 P200 IEC200L2	164
423	760	2,3	7	16800	—		VF 210_7 P200 IEC200L2	158

45 kW

n ₂ min-1	M ₂ Nm	S	i	R _{n2} N	 IE...		 IE...	
74	4994	0,9	20	32300	—		VF 250_20 P225 IEC225M4	164
99	3833	1	15	30100	—		VF 250_15 P225 IEC225M4	164
148	2584	1	10	19200	—		VF 210_10 P225 IEC225M4	158
148	2613	1,4	10	27300	—		VF 250_10 P225 IEC225M4	164
211	1829	1,3	7	17800	—		VF 210_7 P225 IEC225M4	158
211	1850	1,7	7	25000	—		VF 250_7 P225 IEC225M4	164
296	1307	1,5	10	17800	—		VF 210_10 P200 IEC225M2	158
296	1321	2,1	10	24000	—		VF 250_10 P200 IEC225M2	164
423	925	1,9	7	16200	—		VF 210_7 P200 IEC225M2	158
423	935	2,6	7	21800	—		VF 250_7 P200 IEC225M2	164



Die technischen Daten müssen als Anhaltswert betrachtet werden, die genaue Konfiguration muss mit den Daten der Motorenlieferanten für Motoren mit Leistungen größer als 22kW abgestimmt werden.



22 GETRIEBE AUSWAHLTABELLEN



VF 27

13 Nm

		i	η_s %	n_2	M_{n2}	P_{n1}	R_{n1}	R_{n2}	η_d	n_2	M_{n2}	P_{n1}	R_{n1}	R_{n2}	η_d	
				min ⁻¹	Nm	kW	N	N	%	min ⁻¹	Nm	kW	N	N	%	
				$n_1 = 2800 \text{ min}^{-1}$					$n_1 = 1400 \text{ min}^{-1}$							
VF 27	VF 27_7	7	67	400	7	0.34	—	330	86	200	9	0.23	35	410	83	166
	VF 27_10	10	62	280	7	0.24	—	400	84	140	9	0.16	30	500	80	
	VF 27_15	15	54	187	7	0.17	—	480	79	93	9	0.12	—	600	75	
	VF 27_20	20	49	140	7	0.14	—	540	76	70	9	0.09	—	600	71	
	VF 27_30	30	38	93	7	0.10	—	600	69	47	9	0.07	—	600	62	
	VF 27_40	40	33	70	7	0.08	—	600	64	35	9	0.06	—	600	57	
	VF 27_60	60	26	47	7	0.06	—	600	56	23.3	9	0.04	—	600	49	
	VF 27_70	70	24	40	7	0.06	—	600	53	20.0	9	0.04	—	600	45	
					$n_1 = 900 \text{ min}^{-1}$					$n_1 = 500 \text{ min}^{-1}$						
	VF 27_7	7	67	129	10	0.17	90	480	81	71	11	0.11	90	600	79	166
	VF 27_10	10	62	90	11	0.13	20	570	78	50	12	0.08	90	600	76	
	VF 27_15	15	54	60	11	0.09	—	600	72	33	12	0.06	90	600	69	
	VF 27_20	20	49	45	11	0.08	—	600	68	25.0	12	0.05	90	600	65	
	VF 27_30	30	38	30.0	11	0.06	—	600	59	16.7	13	0.04	—	600	55	
VF 27_40	40	33	22.5	11	0.05	—	600	54	12.5	13	0.04	—	600	50		
VF 27_60	60	26	15.0	11	0.04	—	600	45	8.3	12	0.02	—	600	41		
VF 27_70	70	24	12.9	10	0.03	—	600	42	7.1	11	0.02	—	600	38		

VF 30

24 Nm

		i	η_s %	n_2	M_{n2}	P_{n1}	R_{n1}	R_{n2}	η_d	n_2	M_{n2}	P_{n1}	R_{n1}	R_{n2}	η_d	
				min ⁻¹	Nm	kW	N	N	%	min ⁻¹	Nm	kW	N	N	%	
				$n_1 = 2800 \text{ min}^{-1}$					$n_1 = 1400 \text{ min}^{-1}$							
VF 30	VF 30_7	7	69	400	12	0.58	120	510	87	200	16	0.41	140	630	84	166
	VF 30_10	10	64	280	12	0.41	70	620	85	140	16	0.30	80	770	81	
	VF 30_15	15	56	187	14	0.34	—	720	81	93	18	0.24	—	910	76	
	VF 30_20	20	51	140	14	0.26	—	820	78	70	18	0.19	—	1030	73	
	VF 30_30	30	41	93	15	0.21	—	960	71	47	20	0.15	—	1200	65	
	VF 30_40	40	36	70	14	0.16	—	1090	66	35	19	0.12	—	1360	60	
	VF 30_60	60	29	47	14	0.12	—	1270	59	23.3	19	0.09	—	1590	51	
	VF 30_70	70	26	40	11	0.08	—	1380	55	20.0	15	0.07	—	1600	48	
					$n_1 = 900 \text{ min}^{-1}$					$n_1 = 500 \text{ min}^{-1}$						
	VF 30_7	7	69	129	18	0.30	150	730	82	71	20	0.19	150	920	81	166
	VF 30_10	10	64	90	18	0.22	150	900	79	50	20	0.14	150	1120	77	
	VF 30_15	15	56	60	20	0.17	—	1060	74	33	22	0.11	150	1320	71	
	VF 30_20	20	51	45	20	0.14	—	1200	70	25.0	22	0.09	150	1490	67	
	VF 30_30	30	41	30	22	0.12	—	1400	61	16.7	24	0.07	—	1700	58	
VF 30_40	40	36	23	20	0.09	—	1590	56	12.5	22	0.06	—	1700	53		
VF 30_60	60	29	15	20	0.07	—	1650	48	8.3	22	0.05	—	1700	44		
VF 30_70	70	26	13	17	0.05	—	1700	45	7.0	19	0.04	—	1700	41		

(-) Nehmen Sie bitte Kontakt mit unserem Applikationsdienst und Querkraftsdaten angeben (Drehrichtung, Orientierung, Anordnung)



VF 44 - VF/VF 30/44

55 Nm

		i	η _s %	n ₁ = 2800 min ⁻¹						n ₁ = 1400 min ⁻¹								
				n ₂ min ⁻¹	M _{n2} Nm	P _{n1} kW	R _{n1} N	R _{n2} N	η _d %	n ₂ min ⁻¹	M _{n2} Nm	P _{n1} kW	R _{n1} N	R _{n2} N	η _d %			
				VF 44	VF 44_7	7	71	400	22	1.1	220	950	88	200	29		0.71	220
VF 44_10	10	66	280		22	0.74	220	1150	87	140	29	0.51	220	1430	84			
VF 44_14	14	60	200		22	0.55	220	1340	84	100	29	0.37	220	1680	81			
VF 44_20	20	55	140		29	0.52	220	1490	81	70	39	0.37	220	1860	77			
VF 44_28	28	45	100		29	0.40	220	1710	76	50	39	0.29	220	2140	71			
VF 44_35	35	42	80		29	0.33	220	1870	73	40	39	0.25	220	2300	68			
VF 44_46	46	37	61		29	0.27	220	2080	69	30.0	39	0.19	220	2300	63			
VF 44_60	60	32	47		29	0.22	220	2290	65	23.3	39	0.16	220	2300	58			
VF 44_70	70	30	40		22	0.15	220	2300	62	20.0	29	0.11	220	2300	55			
VF 44_100	100	24	28		21	0.11	220	2300	55	14.0	28	0.09	220	2300	47			
					n ₁ = 900 min ⁻¹						n ₁ = 500 min ⁻¹							
VF 44_7	7	71	129		39	0.63	220	1300	85	71	45	0.41	220	1610	83	166		
VF 44_10	10	66	90		39	0.45	220	1610	82	50	45	0.29	220	1980	80			
VF 44_14	14	60	64		39	0.34	220	1890	78	36	50	0.25	220	2280	76			
VF 44_20	20	55	45		45	0.29	220	2160	74	25.0	50	0.18	220	2500	72			
VF 44_28	28	45	32		49	0.24	220	2300	67	17.9	55	0.16	220	2500	64			
VF 44_35	35	42	25.7		49	0.20	220	2300	64	14.3	55	0.14	220	2500	60			
VF 44_46	46	37	19.6		49	0.17	220	2300	59	10.9	50	0.10	220	2500	55			
VF 44_60	60	32	15.0	45	0.13	200	2300	54	8.3	50	0.09	220	2500	50				
VF 44_70	70	30	12.9	39	0.10	220	2300	51	7.1	45	0.07	220	2500	47				
VF 44_100	100	24	9.0	30	0.06	220	2300	43	5.0	32	0.04	220	2500	39				

70 Nm

		i	η _s %	n ₁ = 1400 min ⁻¹						n ₁ = 900 min ⁻¹						
				n ₂ min ⁻¹	M _{n2} Nm	P _{n1} kW	R _{n1} N	R _{n2} N	η _d %	n ₂ min ⁻¹	M _{n2} Nm	P _{n1} kW	R _{n1} N	R _{n2} N	η _d %	
				VF/VF 30/44	VF/VF 30/44_245	245	29	5.7	60	0.09	140	2500	40	3.7	70	
VF/VF 30/44_350	350	27	4.0		60	0.07	80	2500	36	2.6	70	0.05	150	2500	38	
VF/VF 30/44_420	420	25	3.3		60	0.06	—	2500	35	2.1	70	0.04	—	2500	39	
VF/VF 30/44_560	560	23	2.5		60	0.05	—	2500	31	1.6	70	0.04	—	2500	29	
VF/VF 30/44_700	700	21	2.0		60	0.04	—	2500	31	1.3	70	0.03	—	2500	31	
VF/VF 30/44_840	840	18	1.7		60	0.04	—	2500	26	1.1	70	0.03	—	2500	26	
VF/VF 30/44_1120	1120	16	1.3		60	0.03	—	2500	26	0.80	70	0.02	—	2500	29	
VF/VF 30/44_1680	1680	13	0.83		60	0.02	—	2500	26	0.54	70	0.02	—	2500	20	
VF/VF 30/44_2100	2100	12	0.67		60	0.02	—	2500	21	0.43	70	0.02	—	2500	16	

(-) Nehmen Sie bitte Kontakt mit unserem Applikationsdienst und Querkräften an (Drehrichtung, Orientierung, Anordnung)



VF 49 - VFR 49

88 Nm

		i	η _s %	n ₁ = 2800 min ⁻¹						n ₁ = 1400 min ⁻¹						
				n ₂ min ⁻¹	M _{n2} Nm	P _{n1} kW	R _{n1} N	R _{n2} N	η _d %	n ₂ min ⁻¹	M _{n2} Nm	P _{n1} kW	R _{n1} N	R _{n2} N	η _d %	
				VF 49												
				400	41	2.0	400	950	88	200	54	1.3	400	1170	86	166
				280	44	1.5	400	1140	86	140	59	1.0	400	1410	84	
				200	49	1.2	400	1310	84	100	65	0.90	400	1630	81	
				156	44	0.87	400	1520	82	78	59	0.60	400	1890	78	
				117	47	0.73	400	1670	79	58	63	0.50	400	2110	75	
				100	56	0.78	400	1740	75	50	74	0.55	400	2170	71	
				78	52	0.59	400	1970	72	39	69	0.42	400	2460	67	
				62	49	0.46	400	2180	69	31	65	0.33	400	2725	63	
				47	44	0.34	400	2480	64	23.3	59	0.25	400	3100	58	
				40	41	0.28	400	2650	61	20.0	55	0.21	400	3150	54	
				35	41	0.25	400	2780	59	17.5	54	0.19	400	3150	52	
				28.0	37	0.20	400	3050	54	14.0	49	0.13	400	3150	47	
				n ₁ = 900 min ⁻¹						n ₁ = 500 min ⁻¹						
				129	61	0.97	400	1370	85	71	74	0.67	400	1670	83	166
				90	64	0.75	400	1670	82	50	74	0.49	400	2060	80	
				64	71	0.61	400	1920	78	36	78	0.39	400	2400	75	
				50	68	0.47	400	2190	75	27.8	74	0.30	400	2730	72	
				38	68	0.36	400	2480	71	20.8	74	0.24	400	3090	68	
				32	82	0.41	400	2540	67	17.9	88	0.26	400	3180	63	
				25.0	75	0.31	400	2880	63	13.9	80	0.20	400	3450	59	
				20.0	71	0.25	400	3190	59	11.1	78	0.17	400	3450	55	
				15.0	64	0.19	400	3300	53	8.3	69	0.12	400	3450	49	
				12.9	60	0.16	400	3300	50	7.1	69	0.11	400	3450	46	
				11.3	58	0.14	400	3300	47	6.3	59	0.09	400	3450	43	
				9.0	52	0.11	400	3300	42	5.0	59	0.08	400	3450	38	



95 Nm

		i	η _s %	n ₁ = 2800 min ⁻¹						n ₁ = 1400 min ⁻¹						
				n ₂ min ⁻¹	M _{n2} Nm	P _{n1} kW	R _{n1} N	R _{n2} N	η _d %	n ₂ min ⁻¹	M _{n2} Nm	P _{n1} kW	R _{n1} N	R _{n2} N	η _d %	
				VFR 49												
				67	71	0.65	230	1920	76	33	78	0.37	230	2500	74	167
				52	68	0.50	230	2180	74	25.9	74	0.28	230	2830	71	
				39	68	0.40	230	2470	70	19.4	74	0.22	230	3190	67	
				33	82	0.44	230	2520	66	16.6	88	0.25	230	3290	62	
				25.9	75	0.33	230	2860	62	12.9	80	0.19	230	3450	58	
				20.7	71	0.27	230	3160	58	10.3	88	0.18	230	3450	54	
				15.6	64	0.20	230	3300	52	7.7	69	0.12	230	3450	48	
				13.3	60	0.17	230	3300	49	6.6	69	0.11	230	3450	45	
				11.7	58	0.15	230	3300	46	5.8	59	0.09	230	3450	42	
				9.3	52	0.12	230	3300	41	4.7	59	0.08	230	3450	37	
				n ₁ = 900 min ⁻¹						n ₁ = 500 min ⁻¹						
				21.4	82	0.26	230	2960	72	11.9	90	0.16	230	3450	70	167
				16.7	79	0.20	230	3330	69	9.3	83	0.12	230	3450	67	
				12.5	79	0.16	230	3450	64	6.9	83	0.10	230	3450	62	
				10.7	91	0.17	230	3450	59	6.0	95	0.10	230	3450	57	
				8.3	84	0.13	230	3450	55	4.6	90	0.08	230	3450	52	
				6.7	82	0.11	230	3450	50	3.7	90	0.07	230	3450	48	
				5.0	75	0.09	230	3450	45	2.8	78	0.05	230	3450	42	
				4.3	75	0.08	230	3450	41	2.4	78	0.05	230	3450	39	
				3.8	64	0.06	230	3450	39	2.1	68	0.04	230	3450	36	
				3.0	63	0.06	230	3450	34	1.7	65	0.04	230	3450	32	



VF/VF 30/49

100 Nm

		i	η _s %	n ₁ = 1400 min ⁻¹						n ₁ = 900 min ⁻¹						
				n ₂ min ⁻¹	M _{n2} Nm	P _{n1} kW	R _{n1} N	R _{n2} N	η _d %	n ₂ min ⁻¹	M _{n2} Nm	P _{n1} kW	R _{n1} N	R _{n2} N	η _d %	
VF/VF 30/49	VF/VF 30/49_240	240	32	5.8	95	0.13	80	3450	45	3.8	100	0.09	150	3450	44	168
	VF/VF 30/49_315	315	24	4.4	95	0.11	140	3450	40	2.9	100	0.07	150	3450	43	
	VF/VF 30/49_420	420	24	3.3	95	0.08	—	3450	41	2.1	100	0.06	—	3450	37	
	VF/VF 30/49_540	540	22	2.6	95	0.07	—	3450	37	1.7	100	0.05	—	3450	35	
	VF/VF 30/49_720	720	20	1.9	95	0.05	—	3450	39	1.3	100	0.04	—	3450	33	
	VF/VF 30/49_900	900	18	1.6	95	0.05	—	3450	31	1.0	100	0.04	—	3450	26	
	VF/VF 30/49_1120	1120	15	1.3	95	0.04	—	3450	31	0.80	100	0.03	—	3450	28	
	VF/VF 30/49_1440	1440	14	0.97	95	0.04	—	3450	24	0.63	100	0.03	—	3450	22	
	VF/VF 30/49_2160	2160	11	0.65	95	0.03	—	3450	21	0.42	100	0.02	—	3450	22	
	VF/VF 30/49_2700	2700	10	0.52	95	0.03	—	3450	17	0.33	100	0.02	—	3450	17	

(-) Nehmen Sie bitte Kontakt mit unserem Applikationsdienst und Querkraftsdaten angeben (Drehrichtung, Orientierung, Anordnung)



W 63 - WR 63

190 Nm

				i	η _s %	n ₂ min ⁻¹	M _{n2} Nm	P _{n1} kW	R _{n1} N	R _{n2} N	η _d %	n ₂ min ⁻¹	M _{n2} Nm	P _{n1} kW	R _{n1} N	R _{n2} N		η _d %
W 63	W 63_7	7	70	400	105	4.9	480	1010	90	200	120	2.9	480	1550	88	166		
	W 63_10	10	66	280	125	4.2	370	1360	88	140	140	2.4	480	1840	86			
	W 63_12	12	63	233	125	3.5	435	1540	87	117	140	2.0	480	2070	85			
	W 63_15	15	59	187	125	2.8	410	1770	86	93	150	1.8	480	2280	83			
	W 63_19	19	55	147	130	2.4	310	1990	84	74	150	1.4	480	2600	81			
	W 63_24	24	52	117	130	1.9	370	2250	82	58	155	1.2	480	2890	78			
	W 63_30	30	44	93	125	1.6	440	2540	78	47	160	1.1	460	3170	74			
	W 63_38	38	40	74	130	1.3	330	2800	75	37	155	0.85	480	3580	70			
	W 63_45	45	37	62	130	1.2	380	3020	73	31	145	0.71	480	3920	67			
	W 63_64	64	31	44	110	0.75	480	3650	67	21.9	125	0.47	480	4680	61			
W 63_80	80	27	35	100	0.59	480	4050	62	17.5	115	0.38	480	5000	56				
W 63_100	100	23	28	100	0.51	480	4420	58	14.0	115	0.33	480	5000	51				
				n ₁ = 900 min ⁻¹							n ₁ = 500 min ⁻¹							
W 63	W 63_7	7	70	129	130	2.0	480	1870	87	71	140	1.2	480	2420	84	166		
	W 63_10	10	66	90	150	1.7	480	2220	84	50	165	1.1	480	2830	81			
	W 63_12	12	63	75	150	1.4	480	2480	82	42	165	0.92	480	3140	79			
	W 63_15	15	59	60	160	1.3	480	2740	80	33	180	0.83	480	3430	76			
	W 63_19	19	55	47	160	1.0	480	3100	78	26.3	180	0.68	480	3860	73			
	W 63_24	24	52	38	165	0.86	480	3440	75	20.8	185	0.58	480	4280	70			
	W 63_30	30	44	30	170	0.76	480	3770	70	16.7	190	0.52	480	4690	64			
	W 63_38	38	40	23.7	165	0.62	480	4240	66	13.2	185	0.42	480	5000	61			
	W 63_45	45	37	20.0	155	0.52	480	4630	63	11.1	170	0.34	480	5000	58			
	W 63_64	64	31	14.1	135	0.35	480	5000	56	7.8	150	0.24	480	5000	51			
W 63_80	80	27	11.3	125	0.28	480	5000	52	6.3	135	0.19	480	5000	46				
W 63_100	100	23	9.0	120	0.25	480	5000	46	5.0	130	0.17	480	5000	41				

220 Nm

				i	η _s %	n ₂ min ⁻¹	M _{n2} Nm	P _{n1} kW	R _{n1} N	R _{n2} N	η _d %	n ₂ min ⁻¹	M _{n2} Nm	P _{n1} kW	R _{n1} N	R _{n2} N		η _d %
WR 63	WR 63_21	21	69	133	130	2.1	180	1840	87	67	140	1.2	320	2510	84	167		
	WR 63_30	30	65	93	150	1.7	300	2180	84	47	165	1.0	320	2920	81			
	WR 63_36	36	62	78	150	1.5	320	2430	82	39	165	0.85	320	3240	79			
	WR 63_45	45	58	62	160	1.3	320	2690	80	31	180	0.77	320	3540	76			
	WR 63_57	57	54	49	160	1.1	320	3050	78	24.6	180	0.63	320	3980	73			
	WR 63_72	72	51	39	165	0.90	320	3390	75	19.4	185	0.54	320	4410	70			
	WR 63_90	90	44	31	170	0.79	320	3710	70	15.6	190	0.48	320	4830	64			
	WR 63_114	114	39	24.6	165	0.62	320	4170	68	12.3	185	0.39	320	5000	61			
	WR 63_135	135	36	20.7	155	0.53	320	4560	63	10.4	170	0.32	320	5000	58			
	WR 63_192	192	30	14.6	135	0.37	320	5000	56	7.3	150	0.22	320	5000	51			
WR 63_240	240	26	11.7	125	0.29	320	5000	52	5.8	135	0.18	320	5000	46				
WR 63_300	300	22	9.3	120	0.25	320	5000	46	4.7	130	0.15	320	5000	41				
				n ₁ = 900 min ⁻¹							n ₁ = 500 min ⁻¹							
WR 63	WR 63_21	21	69	43	155	0.85	320	2960	82	23.8	170	0.53	320	3750	80	167		
	WR 63_30	30	65	30	180	0.72	320	3470	79	16.7	200	0.45	320	4360	77			
	WR 63_36	36	62	25.0	180	0.61	320	3830	77	14.0	200	0.40	320	4790	74			
	WR 63_45	45	58	20.0	190	0.54	320	4230	74	11.1	200	0.33	320	5000	71			
	WR 63_57	57	54	15.8	190	0.44	320	4740	71	8.8	200	0.27	320	5000	68			
	WR 63_72	72	51	12.5	190	0.37	320	5000	68	6.9	190	0.22	320	5000	64			
	WR 63_90	90	44	10.0	205	0.35	320	5000	62	5.6	220	0.22	320	5000	58			
	WR 63_114	114	39	7.9	200	0.29	320	5000	58	4.4	210	0.18	320	5000	54			
	WR 63_135	135	36	6.7	180	0.23	320	5000	54	3.7	190	0.15	320	5000	50			
	WR 63_192	192	30	4.7	150	0.16	320	5000	47	2.6	150	0.10	320	5000	43			
WR 63_240	240	26	3.8	140	0.13	320	5000	43	2.1	140	0.08	320	5000	39				
WR 63_300	300	22	3.0	130	0.11	320	5000	38	1.7	130	0.07	320	5000	34				



VF/W 30/63

230 Nm

		i	η _s %	n ₁ = 1400 min ⁻¹						n ₁ = 900 min ⁻¹						
				n ₂ min ⁻¹	M _{n2} Nm	P _{n1} kW	R _{n1} N	R _{n2} N	η _d %	n ₂ min ⁻¹	M _{n2} Nm	P _{n1} kW	R _{n1} N	R _{n2} N	η _d %	
VF/W 30/63	VF/W 30/63_240	240	33	5.8	210	0.27	80	5000	47	3.8	230	0.20	150	5000	45	168
	VF/W 30/63_315	315	26	4.4	210	0.23	140	5000	42	2.9	230	0.17	150	5000	41	
	VF/W 30/63_450	450	25	3.1	210	0.17	—	5000	41	2.0	230	0.11	—	5000	42	
	VF/W 30/63_570	570	22	2.5	210	0.14	—	5000	40	1.6	230	0.11	—	5000	36	
	VF/W 30/63_720	720	21	1.9	210	0.12	—	5000	37	1.3	230	0.09	—	5000	32	
	VF/W 30/63_900	900	18	1.6	210	0.11	—	5000	30	1.0	230	0.08	—	5000	29	
	VF/W 30/63_1200	1200	16	1.2	210	0.11	—	5000	24	0.75	230	0.07	—	5000	25	
	VF/W 30/63_1520	1520	14	0.92	210	0.08	—	5000	24	0.59	230	0.06	—	5000	23	
	VF/W 30/63_2280	2280	12	0.61	210	0.06	—	5000	21	0.39	230	0.04	—	5000	23	
	VF/W 30/63_2700	2700	11	0.52	210	0.05	—	5000	22	0.33	230	0.04	—	5000	19	

(-) Nehmen Sie bitte Kontakt mit unserem Applikationsdienst und Querkräften Daten angeben (Drehrichtung, Orientierung, Anordnung)



W 75 - WR 75

320 Nm

		i	η _s %	n ₁ = 2800 min ⁻¹						n ₁ = 1400 min ⁻¹								
				n ₂ min ⁻¹	M _{n2} Nm	P _{n1} kW	R _{n1} N	R _{n2} N	η _d %	n ₂ min ⁻¹	M _{n2} Nm	P _{n1} kW	R _{n1} N	R _{n2} N	η _d %			
				W 75	W 75_7	7	71	400	170	7.8	750	700	91	200	190		4.4	750
W 75_10	10	67	280		205	6.7	750	1610	90	140	230	3.8	750	2240	88			
W 75_15	15	60	187		225	5.0	750	2120	88	93	250	2.9	750	2870	85			
W 75_20	20	56	140		225	3.8	750	2550	86	70	250	2.2	750	3410	83			
W 75_25	25	52	112		225	3.2	750	2900	83	56	250	1.8	750	3840	80			
W 75_30	30	45	93		240	2.9	750	3100	81	47	270	1.7	750	4090	77			
W 75_40	40	40	70		225	2.1	750	3660	77	35	255	1.3	750	4770	72			
W 75_50	50	36	56		195	1.6	750	4180	73	28.0	220	0.95	750	5410	68			
W 75_60	60	33	47		180	1.3	750	4610	70	23.3	200	0.75	750	5960	65			
W 75_80	80	28	35		160	0.90	750	5310	65	17.5	180	0.56	750	6200	59			
W 75_100	100	25	28.0		135	0.65	750	5960	61	14.0	150	0.40	750	6200	55			
					n ₁ = 900 min ⁻¹						n ₁ = 500 min ⁻¹							
W 75	W 75_7	7	71		129	205	3.1	750	2120	88	71	225	2.0	750	2940	86	166	
	W 75_10	10	67		90	250	2.7	750	2700	86	50	275	1.7	750	3480	84		
	W 75_15	15	60		60	270	2.0	750	3440	83	33	295	1.3	750	4380	80		
	W 75_20	20	56		45	270	1.6	750	4050	80	25.0	295	1.0	750	5120	77		
	W 75_25	25	52		36	270	1.3	750	4550	77	20.0	295	0.85	750	5720	73		
	W 75_30	30	45		30	290	1.2	750	4860	74	16.7	320	0.81	750	6080	69		
	W 75_40	40	40		22.5	275	1.0	750	5630	68	12.5	305	0.63	750	6200	63		
	W 75_50	50	36	18.0	235	0.70	750	6200	63	10.0	260	0.47	750	6200	58			
	W 75_60	60	33	15.0	215	0.56	750	6200	60	8.3	235	0.37	750	6200	55			
	W 75_80	80	28	11.3	195	0.43	750	6200	54	6.3	215	0.29	750	6200	49			
W 75_100	100	25	9.0	160	0.30	750	6200	50	5.0	180	0.21	750	6200	44				

420 Nm

		i	η _s %	n ₁ = 2800 min ⁻¹						n ₁ = 1400 min ⁻¹								
				n ₂ min ⁻¹	M _{n2} Nm	P _{n1} kW	R _{n1} N	R _{n2} N	η _d %	n ₂ min ⁻¹	M _{n2} Nm	P _{n1} kW	R _{n1} N	R _{n2} N	η _d %			
				WR 75	WR 75_21	21	70	133	205	3.3	500	2030	88	67	225		1.8	500
WR 75_30	30	66	93		250	2.8	500	2640	86	47	275	1.6	500	3610	84			
WR 75_45	45	59	62		270	2.1	500	3380	83	31	295	1.2	500	4530	80			
WR 75_60	60	55	47		270	1.6	500	3980	80	23.3	295	0.94	500	5280	77			
WR 75_75	75	51	37		270	1.4	500	4480	77	18.7	295	0.79	500	5890	73			
WR 75_90	90	44	31		290	1.3	500	4780	74	15.6	320	0.76	500	6200	69			
WR 75_120	120	39	23.3		275	1.0	500	5540	68	11.7	305	0.59	500	6200	63			
WR 75_150	150	35	18.7		235	0.73	500	6200	63	9.3	260	0.44	500	6200	58			
WR 75_180	180	32	15.6		215	0.58	500	6200	60	7.8	235	0.35	500	6200	55			
WR 75_240	240	27	11.7		195	0.44	500	6200	54	5.8	215	0.27	500	6200	49			
WR 75_300	300	24	9.3		160	0.31	500	6200	50	4.7	180	0.20	500	6200	44			
					n ₁ = 900 min ⁻¹						n ₁ = 500 min ⁻¹							
WR 75	WR 75_21	21	70		43	245	1.3	500	3660	85	23.8	270	0.82	500	4660	82	167	
	WR 75_30	30	66		30	330	1.3	500	4070	82	16.7	370	0.81	500	5160	80		
	WR 75_45	45	59		20.0	350	0.94	500	5180	78	11.1	400	0.62	500	6200	75		
	WR 75_60	60	55		15.0	330	0.69	500	6180	75	8.3	370	0.45	500	6200	71		
	WR 75_75	75	51		12.0	330	0.59	500	6200	70	6.7	350	0.37	500	6200	66		
	WR 75_90	90	44		10.0	370	0.58	500	6200	67	5.6	420	0.39	500	6200	63		
	WR 75_120	120	39		7.5	330	0.43	500	6200	60	4.2	380	0.30	500	6200	56		
	WR 75_150	150	35	6.0	310	0.35	500	6200	55	3.3	350	0.24	500	6200	51			
	WR 75_180	180	32	5.0	280	0.29	500	6200	51	2.8	320	0.20	500	6200	47			
	WR 75_240	240	27	3.8	220	0.19	500	6200	45	2.1	280	0.15	500	6200	41			
WR 75_300	300	24	3.0	200	0.15	500	6200	41	1.7	260	0.12	500	6200	37				



WR 75 - VF/W 44/75

370 Nm

	i	η_s %	$n_1 = 2800 \text{ min}^{-1}$						$n_1 = 1400 \text{ min}^{-1}$							
			n_2 min ⁻¹	M_{n2} Nm	P_{n1} kW	R_{n1} N	R_{n2} N	η_d %	n_2 min ⁻¹	M_{n2} Nm	P_{n1} kW	R_{n1} N	R_{n2} N	η_d %		
			WR 75_P90_B5													
WR 75_P90_B5	WR 75_15	15	66	187	220	4.8	—	1960	89	93	250	2.8	—	2640	86	167
	WR 75_22.5	22.5	59	124	240	3.6	—	2530	86	62	270	2.1	—	3380	83	
	WR 75_30	30	55	93	240	2.8	—	3020	84	47	270	1.6	—	3980	80	
	WR 75_37.5	37.5	51	75	240	2.3	—	3410	81	37	270	1.4	—	4480	77	
	WR 75_45	45	44	62	255	2.1	—	3660	79	31	290	1.3	—	4780	74	
	WR 75_60	60	39	47	240	1.6	—	4290	74	23.3	275	1.0	—	5540	68	
	WR 75_75	75	35	37	210	1.2	—	4860	70	18.7	235	0.73	—	6200	63	
WR 75_P90_B5																
$n_1 = 900 \text{ min}^{-1}$						$n_1 = 500 \text{ min}^{-1}$										
WR 75_P90_B5	WR 75_15	15	66	60	275	2.1	—	3150	84	33	330	1.4	—	3850	82	167
	WR 75_22.5	22.5	59	40	295	1.5	—	4010	80	22.2	350	1.0	—	4920	78	
	WR 75_30	30	55	30	295	1.2	—	4710	77	16.7	330	0.77	—	5890	75	
	WR 75_37.5	37.5	51	24	295	1.0	—	5280	73	13.3	330	0.66	—	6200	70	
	WR 75_45	45	44	20	320	1.0	—	5610	69	11.1	370	0.64	—	6200	67	
	WR 75_60	60	39	15	305	0.76	—	6200	63	8.3	330	0.48	—	6200	60	
	WR 75_75	75	35	12	260	0.56	—	6200	58	6.7	310	0.39	—	6200	55	

400 Nm



	i	η_s %	$n_1 = 1400 \text{ min}^{-1}$						$n_1 = 900 \text{ min}^{-1}$							
			n_2 min ⁻¹	M_{n2} Nm	P_{n1} kW	R_{n1} N	R_{n2} N	η_d %	n_2 min ⁻¹	M_{n2} Nm	P_{n1} kW	R_{n1} N	R_{n2} N	η_d %		
			VF/W 44/75													
VF/W 44/75	VF/W 44/75_250	250	34	5.6	370	0.38	220	4560	57	3.6	400	0.29	220	4660	52	168
	VF/W 44/75_300	300	30	4.7	370	0.35	220	5160	51	3.0	400	0.27	220	5150	46	
	VF/W 44/75_400	400	26	3.5	370	0.29	220	6200	46	2.3	400	0.22	220	6200	42	
	VF/W 44/75_525	525	25	2.7	370	0.23	220	6200	44	1.7	400	0.18	220	6200	41	
	VF/W 44/75_700	700	24	2.0	370	0.18	220	6200	42	1.3	400	0.14	220	6200	39	
	VF/W 44/75_920	920	21	1.5	370	0.15	—	6200	40	1.0	400	0.11	60	6200	36	
	VF/W 44/75_1200	1200	18	1.2	370	0.12	—	6200	37	0.75	400	0.10	220	6200	31	
	VF/W 44/75_1500	1500	17	0.93	370	0.10	220	6200	37	0.60	400	0.09	220	6200	29	
	VF/W 44/75_2100	2100	14	0.67	370	0.09	220	6200	30	0.43	400	0.07	220	6200	24	
	VF/W 44/75_2800	2800	12	0.50	370	0.07	220	6200	26	0.32	400	0.06	220	6200	22	

(-) Nehmen Sie bitte Kontakt mit unserem Applikationsdienst und Querkraftsdaten angeben (Drehrichtung, Orientierung, Anordnung)





W 86 - WR 86

440 Nm

		i	η_s %	$n_1 = 2800 \text{ min}^{-1}$					$n_1 = 1400 \text{ min}^{-1}$								
				n_2 min ⁻¹	M_{n2} Nm	P_{n1} kW	R_{n1} N	R_{n2} N	η_d %	n_2 min ⁻¹	M_{n2} Nm	P_{n1} kW	R_{n1} N		R_{n2} N	η_d %	
W 86	W 86_7	7	71	400	225	10.4	850	2930	91	200	250	5.9	850	3920	89	166	
	W 86_10	10	67	280	260	8.5	850	3490	90	140	290	4.8	850	4620	88		
	W 86_15	15	60	187	295	6.6	850	4200	87	93	330	3.8	850	5510	85		
	W 86_20	20	60	140	285	4.9	850	4900	86	70	320	2.8	850	6380	84		
	W 86_23	23	58	122	285	4.3	850	5250	85	61	320	2.5	850	6800	82		
	W 86_30	30	45	93	320	3.9	850	5740	81	47	370	2.4	850	7000	76		
	W 86_40	40	45	70	295	2.7	850	6670	79	35	330	1.6	850	7000	75		
	W 86_46	46	43	61	305	2.5	850	7000	77	30	340	1.5	850	7000	73		
	W 86_56	56	39	50	265	1.8	850	7000	75	25.0	300	1.1	850	7000	70		
	W 86_64	64	37	44	250	1.6	850	7000	73	21.9	280	0.94	850	7000	68		
	W 86_80	80	33	35	225	1.2	850	7000	69	17.5	255	0.73	850	7000	64		
	W 86_100	100	29	28.0	205	0.92	850	7000	65	14.0	230	0.57	850	7000	59		
					$n_1 = 900 \text{ min}^{-1}$					$n_1 = 500 \text{ min}^{-1}$							
	W 86_7	7	71	129	270	4.1	850	4670	88	71	295	2.6	850	5890	85		166
	W 86_10	10	67	90	310	3.4	850	5500	86	50	345	2.2	850	6860	82		
	W 86_15	15	60	60	355	2.7	850	6520	82	33	390	1.7	850	7000	78		
	W 86_20	20	60	45	345	2.0	850	7000	81	25.0	380	1.3	850	7000	77		
	W 86_23	23	58	39	345	1.8	850	7000	80	21.7	380	1.2	850	7000	75		
	W 86_30	30	45	30	400	1.7	850	7000	73	16.7	440	1.1	850	7000	67		
W 86_40	40	45	22.5	355	1.2	850	7000	71	12.5	390	0.77	850	7000	66			
W 86_46	46	43	19.6	365	1.1	850	7000	69	10.9	405	0.73	850	7000	63			
W 86_56	56	39	16.1	325	0.83	850	7000	66	8.9	355	0.55	850	7000	60			
W 86_64	64	37	14.1	300	0.70	850	7000	63	7.8	330	0.47	850	7000	58			
W 86_80	80	33	11.3	275	0.55	850	7000	59	6.3	305	0.38	850	7000	53			
W 86_100	100	29	9.0	250	0.43	850	7000	55	5.0	275	0.29	850	7000	49			

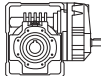
550 Nm

		i	η_s %	$n_1 = 2800 \text{ min}^{-1}$					$n_1 = 1400 \text{ min}^{-1}$								
				n_2 min ⁻¹	M_{n2} Nm	P_{n1} kW	R_{n1} N	R_{n2} N	η_d %	n_2 min ⁻¹	M_{n2} Nm	P_{n1} kW	R_{n1} N		R_{n2} N	η_d %	
WR 86	WR 86_21	21	70	133	270	4.3	500	4590	88	67	295	2.4	500	6070	85	167	
	WR 86_30	30	66	93	310	3.5	500	5410	86	47	345	2.1	500	7000	82		
	WR 86_45	45	59	62	355	2.8	500	6420	82	31	390	1.6	500	7000	78		
	WR 86_60	60	59	47	345	2.1	500	7000	81	23.3	380	1.2	500	7000	77		
	WR 86_69	69	57	41	345	1.8	500	7000	80	20.3	380	1.1	500	7000	75		
	WR 86_90	90	44	31	400	1.8	500	7000	73	15.6	440	1.1	500	7000	67		
	WR 86_120	120	44	23.3	355	1.2	500	7000	71	11.7	390	0.72	500	7000	66		
	WR 86_138	138	42	20.3	365	1.1	500	7000	69	10.1	405	0.68	500	7000	63		
	WR 86_168	168	38	16.7	325	0.86	500	7000	66	8.3	355	0.52	500	7000	60		
	WR 86_192	192	36	14.6	300	0.73	500	7000	63	7.3	330	0.43	500	7000	58		
	WR 86_240	240	32	11.7	275	0.57	500	7000	59	5.8	305	0.35	500	7000	53		
	WR 86_300	300	28	9.3	250	0.44	500	7000	55	4.7	275	0.27	500	7000	49		
					$n_1 = 900 \text{ min}^{-1}$					$n_1 = 500 \text{ min}^{-1}$							
	WR 86_21	21	70	43	325	1.8	500	7000	83	23.8	355	1.1	500	7000	81		167
	WR 86_30	30	66	30	375	1.5	500	7000	81	16.7	415	0.93	500	7000	78		
	WR 86_45	45	59	20.0	450	1.2	500	7000	76	11.1	500	0.80	500	7000	73		
	WR 86_60	60	59	15.0	430	0.90	500	7000	75	8.3	440	0.53	500	7000	72		
	WR 86_69	69	57	13.0	390	0.73	500	7000	73	7.2	400	0.43	500	7000	70		
	WR 86_90	90	44	10.0	500	0.82	500	7000	64	5.6	550	0.53	500	7000	60		
WR 86_120	120	44	7.5	440	0.55	500	7000	63	4.2	470	0.35	500	7000	59			
WR 86_138	138	42	6.5	430	0.48	500	7000	61	3.6	440	0.30	500	7000	56			
WR 86_168	168	38	5.4	390	0.38	500	7000	57	3.0	410	0.24	500	7000	53			
WR 86_192	192	36	4.7	390	0.35	500	7000	55	2.6	410	0.22	500	7000	50			
WR 86_240	240	32	3.8	310	0.24	500	7000	50	2.1	320	0.15	500	7000	46			
WR 86_300	300	28	3.0	310	0.22	500	7000	45	1.7	320	0.14	500	7000	41			



WR 86 - VF/W 44/86

500 Nm

		i	η_s %	$n_1 = 2800 \text{ min}^{-1}$						$n_1 = 1400 \text{ min}^{-1}$									
				n_2 min ⁻¹	M_{n2} Nm	P_{n1} kW	R_{n1} N	R_{n2} N	η_d %	n_2 min ⁻¹	M_{n2} Nm	P_{n1} kW	R_{n1} N	R_{n2} N	η_d %				
				WR 86_P90_B5	WR 86_15	15	66	187	275	6.1	—	4130	88	93	310		3.5	—	5410
WR 86_22.5	22.5	59	124		315	4.8	—	4920	86	62	355	2.8	—	6420	82				
WR 86_30	30	59	93		305	3.5	—	5720	85	47	345	2.1	—	7000	81				
WR 86_34.5	34.5	57	81		305	3.1	—	6110	84	41	345	1.8	—	7000	80				
WR 86_45	45	44	62		350	3.0	—	6640	77	31	400	1.8	—	7000	73				
WR 86_60	60	44	47		315	2.0	—	7000	77	23.3	355	1.2	—	7000	71				
WR 86_69	69	42	41		325	1.8	—	7000	75	20.3	365	1.1	—	7000	69				
WR 86_84	84	38	33		285	1.4	—	7000	72	16.7	325	0.86	—	7000	66				
					$n_1 = 900 \text{ min}^{-1}$						$n_1 = 500 \text{ min}^{-1}$								
WR 86_15	15	66	60		345	2.6	—	6330	82	33	375	1.6	—	7000	81	167			
WR 86_22.5	22.5	59	40		390	2.1	—	7000	78	22.2	450	1.4	—	7000	76				
WR 86_30	30	59	30		380	1.6	—	7000	77	16.7	430	1.0	—	7000	75				
WR 86_34.5	34.5	57	26.1		380	1.4	—	7000	75	14.5	390	0.8	—	7000	73				
WR 86_45	45	44	20.0		440	1.4	—	7000	67	11.1	500	0.9	—	7000	64				
WR 86_60	60	44	15.0	390	0.93	—	7000	66	8.3	440	0.61	—	7000	63					
WR 86_69	69	42	13.0	405	0.88	—	7000	63	7.2	430	0.53	—	7000	61					
WR 86_84	84	38	10.7	355	0.66	—	7000	60	6.0	390	0.43	—	7000	57					

550 Nm

		i	η_s %	$n_1 = 1400 \text{ min}^{-1}$						$n_1 = 900 \text{ min}^{-1}$						
				n_2 min ⁻¹	M_{n2} Nm	P_{n1} kW	R_{n1} N	R_{n2} N	η_d %	n_2 min ⁻¹	M_{n2} Nm	P_{n1} kW	R_{n1} N	R_{n2} N	η_d %	
				VF/W 44/86	VF/W 44/86_230	230	38	6.1	500	0.59	220	7000	54	3.9	550	
VF/W 44/86_300	300	30	4.7		500	0.54	220	7000	45	3.0	550	0.41	220	7000	42	
VF/W 44/86_400	400	30	3.5		500	0.45	220	7000	41	2.3	550	0.32	220	7000	41	
VF/W 44/86_525	525	25	2.7		500	0.33	220	7000	42	1.7	550	0.25	220	7000	39	
VF/W 44/86_700	700	25	2.0		500	0.27	220	7000	39	1.3	550	0.20	220	7000	37	
VF/W 44/86_920	920	22	1.5		500	0.20	220	7000	40	1.0	550	0.15	—	7000	37	
VF/W 44/86_1380	1380	17	1.0		500	0.17	220	7000	32	0.65	550	0.13	—	7000	28	
VF/W 44/86_1840	1840	17	0.76		500	0.13	220	7000	30	0.49	550	0.10	—	7000	28	
VF/W 44/86_2116	2116	16	0.66		500	0.12	220	7000	28	0.43	550	0.09	220	7000	28	
VF/W 44/86_2760	2760	14	0.51	500	0.11	—	7000	24	0.33	550	0.08	220	7000	24		

(-) Nehmen Sie bitte Kontakt mit unserem Applikationsdienst und Querkraftsdaten angeben (Drehrichtung, Orientierung, Anordnung)



W 110 - WR 110

830 Nm

	i	η_s %	$n_1 = 2800 \text{ min}^{-1}$						$n_1 = 1400 \text{ min}^{-1}$							
			n_2 min ⁻¹	M_{n2} Nm	P_{n1} kW	R_{n1} N	R_{n2} N	η_d %	n_2 min ⁻¹	M_{n2} Nm	P_{n1} kW	R_{n1} N	R_{n2} N	η_d %		
W 110	W 110_7	7	71	400	445	20.7	1200	3710	90	200	500	11.8	1200	5020	89	166
	W 110_10	10	67	280	490	16.1	1200	4650	89	140	550	9.3	1200	6190	87	
	W 110_15	15	60	187	535	12.0	1200	5770	87	93	600	7.0	1200	7590	84	
	W 110_20	20	61	140	510	8.7	1200	6790	86	70	570	5.0	1200	8000	84	
	W 110_23	23	59	122	480	7.1	1200	7430	86	61	540	4.1	1200	8000	83	
	W 110_30	30	45	93	625	7.5	1200	7780	81	47	700	4.4	1200	8000	77	
	W 110_40	40	46	70	595	5.5	1200	8000	80	35	670	3.2	1200	8000	76	
	W 110_46	46	44	61	535	4.3	1200	8000	79	30	600	2.6	1200	8000	74	
	W 110_56	56	41	50	535	3.7	1200	8000	76	25.0	600	2.2	1200	8000	72	
	W 110_64	64	38	44	470	2.9	1200	8000	74	21.9	530	1.7	1200	8000	70	
	W 110_80	80	34	35	420	2.2	1200	8000	71	17.5	470	1.3	1200	8000	66	
W 110_100	100	30	28.0	410	1.8	1200	8000	67	14.0	460	1.1	1200	8000	62		
			$n_1 = 900 \text{ min}^{-1}$						$n_1 = 500 \text{ min}^{-1}$							
W 110	W 110_7	7	71	129	540	8.3	1200	6040	88	71	595	5.2	1200	7680	86	166
	W 110_10	10	67	90	590	6.5	1200	7410	86	50	655	4.1	1200	8000	84	
	W 110_15	15	60	60	645	4.9	1200	8000	83	33	710	3.1	1200	8000	80	
	W 110_20	20	61	45	615	3.5	1200	8000	82	25.0	675	2.2	1200	8000	79	
	W 110_23	23	59	39	580	2.9	1200	8000	81	21.7	640	1.9	1200	8000	77	
	W 110_30	30	45	30	755	3.2	1200	8000	74	16.7	830	2.1	1200	8000	70	
	W 110_40	40	46	22.5	720	2.3	1200	8000	73	12.5	795	1.5	1200	8000	68	
	W 110_46	46	44	19.6	645	1.9	1200	8000	71	10.9	710	1.2	1200	8000	66	
	W 110_56	56	41	16.1	645	1.6	1200	8000	68	8.9	710	1.1	1200	8000	63	
	W 110_64	64	38	14.1	570	1.3	1200	8000	65	7.8	630	0.86	1200	8000	60	
	W 110_80	80	34	11.3	505	0.98	1200	8000	61	6.3	560	0.65	1200	8000	56	
W 110_100	100	30	9.0	495	0.82	1200	8000	57	5.0	545	0.56	1200	8000	51		

1000 Nm

	i	η_s %	$n_1 = 2800 \text{ min}^{-1}$						$n_1 = 1400 \text{ min}^{-1}$							
			n_2 min ⁻¹	M_{n2} Nm	P_{n1} kW	R_{n1} N	R_{n2} N	η_d %	n_2 min ⁻¹	M_{n2} Nm	P_{n1} kW	R_{n1} N	R_{n2} N	η_d %		
WR 110	WR 110_21	21	70	133	540	8.6	700	5930	88	67	595	4.8	700	7950	86	167
	WR 110_30	30	66	93	590	6.7	700	7280	86	47	655	3.8	700	8000	84	
	WR 110_45	45	59	62	645	5.1	700	8000	83	31	710	2.9	700	8000	80	
	WR 110_60	60	60	47	615	3.7	700	8000	82	23.3	675	2.1	700	8000	79	
	WR 110_69	69	58	41	580	3.0	700	8000	81	20.3	640	1.8	700	8000	77	
	WR 110_90	90	44	31	755	3.3	700	8000	74	15.6	830	1.9	700	8000	70	
	WR 110_120	120	45	23.3	720	2.4	700	8000	73	11.7	795	1.4	700	8000	68	
	WR 110_138	138	43	20.3	645	1.9	700	8000	71	10.1	710	1.1	700	8000	66	
	WR 110_168	168	40	16.7	645	1.7	700	8000	68	8.3	710	0.98	700	8000	63	
	WR 110_192	192	37	14.6	570	1.3	700	8000	65	7.3	630	0.80	700	8000	60	
	WR 110_240	240	33	11.7	505	1.0	700	8000	61	5.8	560	0.61	700	8000	56	
WR 110_300	300	29	9.3	495	0.85	700	8000	57	4.7	545	0.52	700	8000	51		
			$n_1 = 900 \text{ min}^{-1}$						$n_1 = 500 \text{ min}^{-1}$							
WR 110	WR 110_21	21	70	43	645	3.4	700	8000	84	23.8	715	2.2	700	8000	82	167
	WR 110_30	30	66	30	710	2.8	700	8000	81	16.7	785	1.7	700	8000	79	
	WR 110_45	45	59	20.0	870	2.4	700	8000	77	11.1	950	1.5	700	8000	75	
	WR 110_60	60	60	15.0	800	1.6	700	8000	77	8.3	850	1.0	700	8000	74	
	WR 110_69	69	58	13.0	750	1.4	700	8000	75	7.2	820	0.86	700	8000	72	
	WR 110_90	90	44	10.0	900	1.4	700	8000	66	5.6	1000	0.94	700	8000	62	
	WR 110_120	120	45	7.5	870	1.1	700	8000	65	4.2	950	0.68	700	8000	61	
	WR 110_138	138	43	6.5	800	0.87	700	8000	63	3.6	900	0.58	700	8000	59	
	WR 110_168	168	40	5.4	775	0.72	700	8000	60	3.0	800	0.45	700	8000	55	
	WR 110_192	192	37	4.7	685	0.59	700	8000	57	2.6	720	0.37	700	8000	53	
	WR 110_240	240	33	3.8	590	0.44	700	8000	53	2.1	620	0.28	700	8000	48	
WR 110_300	300	29	3.0	570	0.37	700	8000	48	1.7	600	0.24	700	8000	44		



VF/W 49/110

1050 Nm



	i	η_s %	$n_1 = 1400 \text{ min}^{-1}$							$n_1 = 900 \text{ min}^{-1}$					
			n_2 min ⁻¹	M_{n2} Nm	P_{n1} kW	R_{n1} N	R_{n2} N	η_d %	n_2 min ⁻¹	M_{n2} Nm	P_{n1} kW	R_{n1} N	R_{n2} N	η_d %	
			VF/W 49/110												
VF/W 49/110_230	230	38	6.1	1000	1.2	400	8000	52	3.9	1050	0.84	400	8000	51	168
VF/W 49/110_300	300	29	4.7	1000	1.0	400	8000	48	3.0	1050	0.70	400	8000	47	
VF/W 49/110_400	400	30	3.5	1000	0.81	400	8000	45	2.3	1050	0.55	400	8000	45	
VF/W 49/110_540	540	25	2.6	1000	0.66	400	8000	41	1.7	1050	0.48	400	8000	38	
VF/W 49/110_720	720	24	1.9	1000	0.51	400	8000	40	1.3	1050	0.36	400	8000	38	
VF/W 49/110_1080	1080	18	1.3	1000	0.44	400	8000	31	0.83	1050	0.28	400	8000	30	
VF/W 49/110_1350	1350	16	1.0	1000	0.36	400	8000	30	0.67	1050	0.26	400	8000	28	
VF/W 49/110_1656	1656	17	0.85	1000	0.30	400	8000	30	0.54	1050	0.20	400	8000	30	
VF/W 49/110_2070	2070	15	0.68	1000	0.25	400	8000	28	0.43	1050	0.19	400	8000	25	
VF/W 49/110_2800	2800	13	0.50	1000	0.22	400	8000	24	0.32	1050	0.17	400	8000	21	



VF 130 - VFR 130

1500 Nm

$n_1 = 2800 \text{ min}^{-1}$						$n_1 = 1400 \text{ min}^{-1}$															
VF 130	VF 130_7	7	71	400	555	25	1500	4930	91	200	740	17.4	1500	5990	89	166					
	VF 130_10	10	67	280	593	19.3	1500	6210	90	140	790	13.3	1500	7620	88						
	VF 130_15	15	63	187	690	15.3	1500	7390	88	93	920	10.6	1500	9100	86						
	VF 130_20	20	59	140	675	11.4	1500	8670	87	70	900	8.0	1500	10700	84						
	VF 130_23	23	57	122	668	9.9	1500	9300	86	61	890	6.9	1500	11500	83						
	VF 130_30	30	49	93	788	9.3	1040	10100	83	47	1050	6.6	—	12500	79						
	VF 130_40	40	44	70	825	7.6	—	11400	80	35	1100	5.4	—	12600	76						
	VF 130_46	46	45	61	788	6.3	1290	12200	80	30.0	1050	4.5	—	12600	76						
	VF 130_56	56	42	50	720	4.8	1500	12600	78	25.0	960	3.4	940	12600	73						
	VF 130_64	64	39	44	698	4.2	1500	12600	76	21.9	930	3.0	1220	12600	71						
	VF 130_80	80	35	35	660	3.3	1500	12600	73	17.5	880	2.4	1500	12600	68						
VF 130_100	100	31	28	585	2.5	1500	12600	70	14.0	780	1.8	1500	12600	64							
$n_1 = 900 \text{ min}^{-1}$						$n_1 = 500 \text{ min}^{-1}$															
VF 130	VF 130_7	7	71	129	850	13.0	1500	6980	88	71	1000	8.8	1500	8670	86	166					
	VF 130_10	10	67	90	900	9.9	1500	8900	87	50	1100	6.9	1500	10800	84						
	VF 130_15	15	63	60	1080	8.1	1500	10490	84	33	1350	5.9	1500	12600	81						
	VF 130_20	20	59	45	1050	6.1	1500	12400	82	25.0	1350	4.6	1500	13800	79						
	VF 130_23	23	57	39	1050	5.4	1500	13200	81	21.7	1300	3.9	1500	13800	77						
	VF 130_30	30	49	30.0	1250	5.2	—	13200	77	16.7	1500	3.7	—	13800	72						
	VF 130_40	40	44	22.5	1200	3.9	—	13200	73	12.5	1400	2.8	—	13800	68						
	VF 130_46	46	45	19.6	1150	3.3	490	13200	73	10.9	1350	2.3	1270	13800	68						
	VF 130_56	56	42	16.1	1080	2.7	1500	13200	70	8.9	1200	1.8	1500	13800	65						
	VF 130_64	64	39	14.1	1050	2.4	1500	13200	68	7.8	1200	1.6	1500	13800	62						
	VF 130_80	80	35	11.3	950	1.8	1500	13200	64	6.3	1150	1.3	1500	13800	58						
VF 130_100	100	31	9.0	800	1.3	1500	13200	59	5.0	900	0.91	1500	13800	54							

1800 Nm

$n_1 = 2800 \text{ min}^{-1}$						$n_1 = 1400 \text{ min}^{-1}$														
VFR 130	VFR 130_60	60	58	47	1050	6.4	1000	12400	81	23.3	1350	4.3	1000	13800	78	167				
	VFR 130_69	69	56	41	1050	5.6	1000	13200	80	20.3	1300	3.7	1000	13800	76					
	VFR 130_90	90	48	31	1250	5.4	1000	13200	76	15.6	1500	3.5	1000	13800	71					
	VFR 130_120	120	43	23.3	1200	4.1	1000	13200	72	11.7	1400	2.6	1000	13800	67					
	VFR 130_138	138	44	20.3	1150	3.4	1000	13200	72	10.1	1350	2.2	1000	13800	67					
	VFR 130_168	168	41	16.7	1080	2.7	1000	13200	69	8.3	1200	1.6	1000	13800	64					
	VFR 130_192	192	38	14.6	1050	2.4	1000	13200	67	7.3	1200	1.5	1000	13800	61					
	VFR 130_240	240	34	11.7	950	1.9	1000	13200	63	5.8	1150	1.2	1000	13800	57					
	VFR 130_300	300	30	9.3	800	1.4	1000	13200	58	4.7	900	0.83	1000	13800	53					
$n_1 = 900 \text{ min}^{-1}$						$n_1 = 500 \text{ min}^{-1}$														
VFR 130	VFR 130_60	60	58	15.0	1450	3.1	1000	13800	75	8.3	1600	1.9	1000	13800	74	167				
	VFR 130_69	69	56	13.0	1450	2.7	1000	13800	74	7.2	1550	1.6	1000	13800	72					
	VFR 130_90	90	48	10.0	1600	2.5	1000	13800	68	5.6	1800	1.6	1000	13800	66					
	VFR 130_120	120	43	7.5	1600	2.0	1000	13800	63	4.2	1800	1.3	1000	13800	61					
	VFR 130_138	138	44	6.5	1500	1.6	1000	13800	64	3.6	1600	1.0	1000	13800	61					
	VFR 130_168	168	41	5.4	1350	1.3	1000	13800	60	3.0	1450	0.78	1000	13800	58					
	VFR 130_192	192	38	4.7	1300	1.1	1000	13800	58	2.6	1400	0.70	1000	13800	55					
	VFR 130_240	240	34	3.8	1200	0.87	1000	13800	54	2.1	1250	0.54	1000	13800	51					
	VFR 130_300	300	30	3.0	1000	0.64	1000	13800	49	1.7	1100	0.41	1000	13800	47					

(-) Nehmen Sie bitte Kontakt mit unserem Applikationsdienst und Querkraftsdaten angeben (Drehrichtung, Orientierung, Anordnung)



W/VF 63/130

1850 Nm



W/VF 63/130	i	η_s %	$n_1 = 1400 \text{ min}^{-1}$							$n_1 = 900 \text{ min}^{-1}$					168
			n_2 min ⁻¹	M_{n2} Nm	P_{n1} kW	R_{n1} N	R_{n2} N	η_d %	n_2 min ⁻¹	M_{n2} Nm	P_{n1} kW	R_{n1} N	R_{n2} N	η_d %	
W/VF 63/130_280	280	31	5.0	1800	1.9	480	13800	50	3.2	1850	1.3	480	13800	48	
W/VF 63/130_400	400	29	3.5	1800	1.5	480	13800	44	2.3	1850	0.99	480	13800	44	
W/VF 63/130_600	600	26	2.3	1800	1.1	480	13800	40	1.5	1850	0.73	480	13800	40	
W/VF 63/130_760	760	24	1.8	1800	0.89	480	13800	39	1.2	1850	0.62	480	13800	37	
W/VF 63/130_960	960	23	1.5	1800	0.74	480	13800	37	0.94	1850	0.52	480	13800	35	
W/VF 63/130_1200	1200	19	1.2	1800	0.65	—	13800	34	0.75	1850	0.45	—	13800	32	
W/VF 63/130_1520	1520	18	0.92	1800	0.55	—	13800	32	0.59	1850	0.38	—	13800	30	
W/VF 63/130_1800	1800	16	0.78	1800	0.52	—	13800	28	0.50	1850	0.37	—	13800	26	
W/VF 63/130_2560	2560	14	0.55	1800	0.45	—	13800	23	0.35	1850	0.32	—	13800	21	
W/VF 63/130_3200	3200	12	0.44	1800	0.49	—	13800	17	0.28	1850	0.34	480	13800	16	

(-) Nehmen Sie bitte Kontakt mit unserem Applikationsdienst und Querkraftsdaten angeben (Drehrichtung, Orientierung, Anordnung)



VF 150 - VFR 150

2000 Nm

	i	η _s %	n ₁ = 2800 min ⁻¹							n ₁ = 1400 min ⁻¹								
			n ₂ min ⁻¹	M _{n2} Nm	P _{n1} kW	R _{n1} N	R _{n2} N	η _d %	n ₂ min ⁻¹	M _{n2} Nm	P _{n1} kW	R _{n1} N	R _{n2} N	η _d %				
VF 150	VF 150_7	7	72	400	750	35	2200	5010	91	200	1000	24	2200	6040	90	166		
	VF 150_10	10	68	280	788	25	2200	6630	90	140	1050	17.5	2200	8120	88			
	VF 150_15	15	64	187	863	19.0	2200	8110	89	93	1150	13.1	2200	9990	87			
	VF 150_20	20	59	140	975	16.4	2200	9170	87	70	1300	11.3	2200	11300	84			
	VF 150_23	23	57	122	953	14.1	2200	9940	86	61	1270	9.8	2200	12300	83			
	VF 150_30	30	48	93	1028	12.1	2200	11100	83	47	1370	8.5	2200	13700	80			
	VF 150_40	40	44	70	1155	10.5	2200	12300	81	35	1540	7.4	830	14700	77			
	VF 150_46	46	45	61	1163	9.2	2200	13100	81	30.0	1550	6.5	1400	14700	77			
	VF 150_56	56	42	50	1028	6.8	2200	14600	79	25.0	1370	4.9	2200	14700	74			
	VF 150_64	64	39	44	998	5.9	2200	14700	77	21.9	1330	4.2	2200	14700	72			
	VF 150_80	80	35	35	938	4.6	2200	14700	74	17.5	1250	3.4	2200	14700	69			
VF 150_100	100	31	28	863	3.6	2200	14700	71	14.0	1150	2.6	2200	14700	65				
			n ₁ = 900 min ⁻¹							n ₁ = 500 min ⁻¹								
VF 150	VF 150_7	7	72	129	1150	17.6	2200	7040	89	71	1400	12.2	2200	8560	87	166		
	VF 150_10	10	68	90	1200	13.0	2200	9480	87	50	1500	9.4	2200	11400	85			
	VF 150_15	15	64	60	1350	10.0	2200	11500	85	33	1700	7.3	2200	13800	83			
	VF 150_20	20	59	45	1500	8.6	2200	13100	83	25.0	1900	6.4	2200	15700	80			
	VF 150_23	23	57	39	1500	7.6	2200	14200	82	21.7	1850	5.5	2200	16000	78			
	VF 150_30	30	48	30.0	1600	6.5	2200	15500	77	16.7	1950	4.8	2200	16000	73			
	VF 150_40	40	44	22.5	1750	5.6	1150	15500	74	12.5	2000	3.9	2200	16000	69			
	VF 150_46	46	45	19.6	1750	4.9	2100	15500	74	10.9	2000	3.4	2200	16000	69			
	VF 150_56	56	42	16.1	1500	3.7	2200	15500	71	8.9	1750	2.6	2200	16000	66			
	VF 150_64	64	39	14.1	1450	3.2	2200	15500	69	7.8	1700	2.3	2200	16000	63			
	VF 150_80	80	35	11.3	1350	2.5	2200	15500	65	6.3	1550	1.8	2200	16000	59			
VF 150_100	100	31	9.0	1150	1.8	2200	15500	61	5.0	1300	1.3	2200	16000	55				

2600 Nm

	i	η _s %	n ₁ = 2800 min ⁻¹							n ₁ = 1400 min ⁻¹								
			n ₂ min ⁻¹	M _{n2} Nm	P _{n1} kW	R _{n1} N	R _{n2} N	η _d %	n ₂ min ⁻¹	M _{n2} Nm	P _{n1} kW	R _{n1} N	R _{n2} N	η _d %				
VFR 150	VFR 150_45	45	63	62	1350	10.6	1500	11600	84	31	1700	6.8	1500	14600	82	167		
	VFR 150_60	60	58	47	1500	9.0	1500	13100	82	23.3	1900	5.9	1500	16000	79			
	VFR 150_69	69	56	41	1500	7.9	1500	14100	81	20.3	1850	5.1	1500	16000	77			
	VFR 150_90	90	47	31	1600	6.9	1500	15500	76	15.6	1950	4.4	1500	16000	72			
	VFR 150_120	120	43	23.3	1750	5.9	1500	15500	73	11.7	2000	3.6	1500	16000	68			
	VFR 150_138	138	44	20.3	1750	5.1	1500	15500	73	10.1	2000	3.1	1500	16000	68			
	VFR 150_168	168	41	16.7	1500	3.8	1500	15500	70	8.3	1750	2.4	1500	16000	65			
	VFR 150_192	192	38	14.6	1450	3.3	1500	15500	68	7.3	1700	2.1	1500	16000	62			
	VFR 150_240	240	34	11.7	1350	2.6	1500	15500	64	5.8	1550	1.6	1500	16000	58			
	VFR 150_300	300	30	9.3	1150	1.9	1500	15500	60	4.7	1300	1.2	1500	16000	54			
			n ₁ = 900 min ⁻¹							n ₁ = 500 min ⁻¹								
VFR 150	VFR 150_45	45	63	20.0	1950	5.2	1500	16000	79	11.1	2100	3.2	1500	16000	78	167		
	VFR 150_60	60	58	15.0	2100	4.4	1500	16000	76	8.3	2300	2.7	1500	16000	74			
	VFR 150_69	69	56	13.0	2050	3.8	1500	16000	74	7.2	2200	2.3	1500	16000	72			
	VFR 150_90	90	47	10.0	2200	3.4	1500	16000	69	5.6	2400	2.1	1500	16000	66			
	VFR 150_120	120	43	7.5	2300	2.8	1500	16000	64	4.2	2600	1.8	1500	16000	62			
	VFR 150_138	138	44	6.5	2200	2.4	1500	16000	64	3.6	2400	1.5	1500	16000	62			
	VFR 150_168	168	41	5.4	1950	1.8	1500	16000	61	3.0	2100	1.1	1500	16000	59			
	VFR 150_192	192	38	4.7	1900	1.6	1500	16000	59	2.6	2000	1.0	1500	16000	56			
	VFR 150_240	240	34	3.8	1700	1.2	1500	16000	54	2.1	1800	0.76	1500	16000	52			
	VFR 150_300	300	30	3.0	1350	0.85	1500	16000	50	1.7	1450	0.54	1500	16000	47			



W/VF 86/150

2700 Nm



W/VF 86/150	i	η_s %	$n_1 = 1400 \text{ min}^{-1}$							$n_1 = 900 \text{ min}^{-1}$					168
			n_2 min ⁻¹	M_{n2} Nm	P_{n1} kW	R_{n1} N	R_{n2} N	η_d %	n_2 min ⁻¹	M_{n2} Nm	P_{n1} kW	R_{n1} N	R_{n2} N	η_d %	
W/VF 86/150_200	200	29	7.0	2600	3.0	850	16000	64	4.5	2700	2.1	850	16000	61	
W/VF 86/150_225	225	26	6.2	2600	2.7	850	16000	63	4.0	2700	1.9	850	16000	60	
W/VF 86/150_300	300	26	4.7	2600	2.2	850	16000	58	3.0	2700	1.5	850	16000	57	
W/VF 86/150_345	345	26	4.1	2600	1.9	850	16000	58	2.6	2700	1.3	850	16000	57	
W/VF 86/150_460	460	26	3.0	2600	1.5	850	16000	55	2.0	2700	1.0	850	16000	55	
W/VF 86/150_529	529	26	2.6	2600	1.3	850	16000	55	1.7	2700	0.93	850	16000	52	
W/VF 86/150_690	690	26	2.0	2600	1.1	850	16000	50	1.3	2700	0.78	850	16000	47	
W/VF 86/150_920	920	26	1.5	2600	0.92	850	16000	45	0.98	2700	0.64	850	16000	43	
W/VF 86/150_1380	1380	19	1.0	2600	0.66	850	16000	42	0.65	2700	0.46	850	16000	40	
W/VF 86/150_1840	1840	19	0.76	2600	0.55	850	16000	38	0.49	2700	0.38	850	16000	36	
W/VF 86/150_2944	2944	16	0.48	2600	0.48	850	16000	27	0.31	2700	0.35	850	16000	25	



VF 185 - VFR 185

3600 Nm

			i	η_s %	$n_1 = 2800 \text{ min}^{-1}$					$n_1 = 1400 \text{ min}^{-1}$							
					n_2 min ⁻¹	M_{n2} Nm	P_{n1} kW	R_{n1} N	R_{n2} N	η_d %	n_2 min ⁻¹	M_{n2} Nm	P_{n1} kW	R_{n1} N		R_{n2} N	η_d %
VF 185	VF 185_7	7	72	400	1313	60	2800	4670	91	200	1750	41	2800	5570	90	166	
	VF 185_10	10	68	280	1365	44	2800	7390	90	140	1820	30	2800	8960	89		
	VF 185_15	15	66	187	1388	30	2800	9460	89	93	1850	21	2800	11600	88		
	VF 185_20	20	59	140	1703	28	2800	10500	88	70	2270	19.6	2800	12900	85		
	VF 185_30	30	54	93	1485	16.9	2800	13700	86	47	1980	11.8	2800	16900	83		
	VF 185_40	40	44	70	1973	17.6	—	14500	82	35	2630	12.4	—	17900	78		
	VF 185_50	50	41	56	1875	13.7	—	16300	80	28.0	2500	9.8	—	18000	76		
	VF 185_60	60	39	47	1703	10.7	2800	18000	78	23.3	2270	7.6	770	18000	74		
	VF 185_80	80	33	35	1590	7.8	2800	18000	75	17.5	2120	5.6	1140	18000	69		
	VF 185_100	100	30	28.0	1425	5.8	2800	18000	72	14.0	1900	4.3	2800	18000	65		
						$n_1 = 900 \text{ min}^{-1}$					$n_1 = 500 \text{ min}^{-1}$						
	VF 185_7	7	72	129	2000	30	2800	7120	89	71	2450	21	2800	8730	88	166	
	VF 185_10	10	68	90	2150	23	2800	10200	88	50	2600	16.0	2800	12500	86		
	VF 185_15	15	66	60	2250	16.4	2800	13100	86	33	2800	11.8	2800	15700	84		
	VF 185_20	20	59	45	2750	15.6	2800	14600	84	25.0	3300	10.9	2800	17900	81		
	VF 185_30	30	54	30.0	2400	9.4	2800	19000	81	16.7	2800	6.5	2800	19500	77		
	VF 185_40	40	44	22.5	3100	9.7	—	19000	76	12.5	3600	6.8	—	19500	71		
	VF 185_50	50	41	18.0	2900	7.6	—	19000	73	10.0	3300	5.2	—	19500	68		
VF 185_60	60	39	15.0	2600	5.8	700	19000	71	8.3	3000	4.2	2800	19500	66			
VF 185_80	80	33	11.3	2400	4.3	1770	19000	66	6.3	2800	3.2	2800	19500	60			
VF 185_100	100	30	9.0	2000	3.0	2800	19000	62	5.0	2300	2.1	2800	19500	56			

4200 Nm

			i	η_s %	$n_1 = 2800 \text{ min}^{-1}$					$n_1 = 1400 \text{ min}^{-1}$							
					n_2 min ⁻¹	M_{n2} Nm	P_{n1} kW	R_{n1} N	R_{n2} N	η_d %	n_2 min ⁻¹	M_{n2} Nm	P_{n1} kW	R_{n1} N		R_{n2} N	η_d %
VFR 185	VFR 185_90	90	53	31	2400	9.9	1700	19000	80	15.6	2800	6.0	1700	19500	76	167	
	VFR 185_120	120	43	23.3	3100	10.2	1700	19000	75	11.7	3600	6.3	1700	19500	70		
	VFR 185_150	150	40	18.7	2900	7.9	1700	19000	72	9.3	3300	4.8	1700	19500	67		
	VFR 185_180	180	38	15.6	2600	6.1	1700	19000	70	7.8	3000	3.8	1700	19500	65		
	VFR 185_240	240	32	11.7	2400	4.5	1700	19000	65	5.8	2800	2.9	1700	19500	59		
	VFR 185_300	300	29	9.3	2000	3.2	1700	19000	61	4.7	2300	2.0	1700	19500	55		
						$n_1 = 900 \text{ min}^{-1}$					$n_1 = 500 \text{ min}^{-1}$						
	VFR 185_90	90	53	10.0	3200	4.6	1700	19500	73	5.6	3500	2.9	1700	19500	71	167	
	VFR 185_120	120	43	7.5	3800	4.5	1700	19500	66	4.2	4200	2.9	1700	19500	63		
	VFR 185_150	150	40	6.0	3400	3.4	1700	19500	63	3.3	3700	2.2	1700	19500	60		
	VFR 185_180	180	38	5.0	3300	2.9	1700	19500	60	2.8	3600	1.8	1700	19500	57		
	VFR 185_240	240	32	3.8	2800	2.0	1700	19500	54	2.1	2900	1.2	1700	19500	53		
	VFR 185_300	300	29	3.0	2400	1.5	1700	19500	50	1.7	2500	0.91	1700	19500	48		

(-) Nehmen Sie bitte Kontakt mit unserem Applikationsdienst und Querkräften an (Drehrichtung, Orientierung, Anordnung)



W/VF 86/185

4400 Nm



W/VF 86/185	i	η_s %	$n_1 = 1400 \text{ min}^{-1}$							$n_1 = 900 \text{ min}^{-1}$					168
			n_2 min ⁻¹	M_{n2} Nm	P_{n1} kW	R_{n1} N	R_{n2} N	η_d %	n_2 min ⁻¹	M_{n2} Nm	P_{n1} kW	R_{n1} N	R_{n2} N	η_d %	
W/VF 86/185_280	280	31	5.0	4200	4.2	850	19500	52	3.2	4400	3.0	850	19500	49	
W/VF 86/185_400	400	29	3.5	4200	3.2	850	19500	48	2.3	4400	2.3	850	19500	45	
W/VF 86/185_600	600	26	2.3	4200	2.3	850	19500	45	1.5	4400	1.6	850	19500	43	
W/VF 86/185_800	800	26	1.8	4200	1.8	850	19500	43	1.1	4400	1.3	850	19500	40	
W/VF 86/185_920	920	26	1.5	4200	1.6	850	19500	42	1.0	4400	1.2	850	19500	38	
W/VF 86/185_1200	1200	20	1.2	4200	1.5	850	19500	34	0.75	4400	0.99	850	19500	35	
W/VF 86/185_1600	1600	20	0.88	4200	1.1	850	19500	35	0.56	4400	0.79	850	19500	33	
W/VF 86/185_1840	1840	19	0.76	4200	0.98	850	19500	34	0.49	4400	0.70	850	19500	32	
W/VF 86/185_2560	2560	16	0.55	4200	0.83	850	19500	29	0.35	4400	0.60	850	19500	27	
W/VF 86/185_3200	3200	15	0.44	4200	0.80	850	19500	24	0.28	4400	0.59	850	19500	22	



VF 210 - VFR 210

5000 Nm

		i	η _s %	n ₂					n ₁							
				n ₂ min ⁻¹	M _{n2} Nm	P _{n1} kW	R _{n1} N	R _{n2} N	η _d %	n ₂ min ⁻¹	M _{n2} Nm	P _{n1} kW	R _{n1} N		R _{n2} N	η _d %
				n ₁ = 2800 min ⁻¹					n ₁ = 1400 min ⁻¹							
VF 210	VF 210_7	7	71	400	1725	79	5300	14000	91	200	2300	54	5300	16700	90	166
	VF 210_10	10	69	280	1988	65	5300	16300	90	140	2650	44	5300	19500	89	
	VF 210_15	15	63	187	2138	47	5300	19700	89	93	2850	32	5300	23700	88	
	VF 210_20	20	57	140	2325	39	4970	22000	87	70	3100	27	1100	26600	85	
	VF 210_30	30	51	93	2288	26	5300	25900	85	47	3050	18.5	1760	31500	83	
	VF 210_40	40	42	70	2625	23	—	28300	81	35	3500	17.0	—	31500	78	
	VF 210_50	50	39	56	2475	18.4	—	31000	79	28.0	3300	13.0	—	31500	76	
	VF 210_60	60	36	47	2363	15.0	—	31500	77	23.3	3015	10.0	—	31500	73	
	VF 210_80	80	31	35	2175	10.9	—	31500	73	17.5	2900	7.7	—	31500	69	
	VF 210_100	100	27	28	2025	8.5	950	31500	70	14.0	2700	6.0	—	31500	65	
				n ₁ = 900 min ⁻¹					n ₁ = 500 min ⁻¹							
VF 210	VF 210_7	7	71	129	2700	41	5300	18800	89	71	3400	29	5300	21800	88	166
	VF 210_10	10	69	90	3150	34	5300	21900	88	50	3800	23	5300	26000	87	
	VF 210_15	15	63	60	3300	24	5300	27000	86	33	4100	17.2	5300	31800	84	
	VF 210_20	20	57	45	3800	22	—	29900	83	25.0	4700	15.4	—	34500	81	
	VF 210_30	30	51	30.0	3400	13.4	3750	33000	80	16.7	4000	9.3	5300	34500	77	
	VF 210_40	40	42	22.5	4300	13.5	—	33000	75	12.5	5000	9.4	—	34500	71	
	VF 210_50	50	39	18.0	4000	10.5	—	33000	72	10.0	4500	7.1	—	34500	68	
	VF 210_60	60	36	15.0	3720	8.5	—	33000	70	8.3	4300	6.0	—	34500	65	
	VF 210_80	80	31	11.3	3300	6.0	—	33000	65	6.3	3900	4.4	—	34500	60	
	VF 210_100	100	27	9.0	3000	4.6	—	33000	61	5.0	3400	3.4	1470	34500	56	

6300 Nm

		i	η _s %	n ₂					n ₁							
				n ₂ min ⁻¹	M _{n2} Nm	P _{n1} kW	R _{n1} N	R _{n2} N	η _d %	n ₂ min ⁻¹	M _{n2} Nm	P _{n1} kW	R _{n1} N		R _{n2} N	η _d %
				n ₁ = 2800 min ⁻¹					n ₁ = 1400 min ⁻¹							
VFR 210	VFR 210_30	30	68	93	3150	36	1800	22100	87	47	3800	21.8	2200	27400	86	167
	VFR 210_45	45	62	62	3300	25	1800	27000	85	31	4100	16.2	2200	33200	83	
	VFR 210_60	60	56	47	3800	22	1800	29900	82	23.0	4700	14.5	2200	34500	80	
	VFR 210_90	90	50	31	3400	14.1	1800	33000	79	15.6	4000	8.6	2200	34500	76	
	VFR 210_120	120	41	23.3	4300	14.3	1800	33000	74	11.7	5000	8.8	2200	34500	70	
	VFR 210_150	150	38	18.7	4000	11.1	1800	33000	71	9.3	4500	6.6	2200	34500	67	
	VFR 210_180	180	35	15.6	3720	8.8	1800	33000	69	7.8	4300	5.5	2200	34500	64	
	VFR 210_240	240	30	11.7	3300	6.3	1800	33000	64	5.8	3900	4.1	2200	34500	59	
	VFR 210_300	300	26	9.3	3000	4.9	1800	33000	60	4.7	3400	3.0	2200	34500	55	
					n ₁ = 900 min ⁻¹					n ₁ = 500 min ⁻¹						
VFR 210	VFR 210_30	30	68	30.0	4800	18.1	2300	30100	84	16.7	5500	11.8	2650	34500	82	167
	VFR 210_45	45	62	20.0	4900	12.9	2300	34500	80	11.1	5600	8.4	2650	34500	78	
	VFR 210_60	60	56	15.0	5400	11.1	2300	34500	77	8.3	6000	7.1	2650	34500	74	
	VFR 210_90	90	50	10.0	4600	6.7	2300	34500	72	5.6	5150	4.3	2650	34500	70	
	VFR 210_120	120	41	7.5	5900	7.1	2300	34500	66	4.2	6300	4.4	2650	34500	63	
	VFR 210_150	150	38	6.0	5300	5.4	2300	34500	62	3.3	5900	3.5	2650	34500	59	
	VFR 210_180	180	35	5.0	4900	4.4	2300	34500	59	2.8	5400	2.8	2650	34500	56	
	VFR 210_240	240	30	3.8	4400	3.2	2300	34500	54	2.1	4800	2.1	2650	34500	50	
VFR 210_300	300	26	3.0	3600	2.3	2300	34500	49	1.7	4000	1.5	2650	34500	46		

(-) Nehmen Sie bitte Kontakt mit unserem Applikationsdienst und Querkraftsdaten angeben (Drehrichtung, Orientierung, Anordnung)



VF/VF 130/210

6500 Nm

				$n_1 = 1400 \text{ min}^{-1}$						$n_1 = 900 \text{ min}^{-1}$							
VF/VF 130/210	VF/VF 130/210_280	280	30	5.0	6300	6.3	1500	34500	52	3.2	6500	4.4	1500	34500	50	168	
	VF/VF 130/210_400	400	28	3.5	6300	4.6	1500	34500	50	2.3	6500	3.2	1500	34500	48		
	VF/VF 130/210_600	600	26	2.3	6300	3.6	1500	34500	43	1.5	6500	2.4	1500	34500	43		
	VF/VF 130/210_800	800	25	1.8	6300	2.8	1500	34500	41	1.1	6500	2.0	1500	34500	38		
	VF/VF 130/210_920	920	24	1.5	6300	2.7	1500	34500	37	1.0	6500	1.9	1500	34500	35		
	VF/VF 130/210_1200	1200	21	1.2	6300	2.2	—	34500	35	0.75	6500	1.5	—	34500	34		
	VF/VF 130/210_1600	1600	18	0.88	6300	1.8	—	34500	32	0.56	6500	1.2	—	34500	32		
	VF/VF 130/210_1840	1840	19	0.76	6300	1.7	—	34500	30	0.49	6500	1.2	490	34500	28		
	VF/VF 130/210_2560	2560	16	0.55	6300	1.5	1220	34500	24	0.35	6500	1.0	1500	34500	24		
	VF/VF 130/210_3200	3200	15	0.44	6300	1.3	1500	34500	22	0.28	6500	0.96	1500	34500	20		

(-) Nehmen Sie bitte Kontakt mit unserem Applikationsdienst und Querkräften an (Drehrichtung, Orientierung, Anordnung)



VF 250 - VFR 250

7100 Nm

				n ₁ = 2800 min ⁻¹					n ₁ = 1400 min ⁻¹							
				n ₂	M _{n2}	P _{n1}	R _{n1}	R _{n2}	η _d	n ₂	M _{n2}	P _{n1}	R _{n1}		R _{n2}	η _d
				min ⁻¹	Nm	kW	N	N	%	min ⁻¹	Nm	kW	N		N	%
VF 250	VF 250_7	7	71	400	2400	109	7000	18300	92	200	3200	75	7000	21900	91	166
	VF 250_10	10	69	280	2775	89	7000	21100	91	140	3700	61	7000	25300	90	
	VF 250_15	15	64	187	3000	65	7000	25100	90	93	4000	45	7000	30300	88	
	VF 250_20	20	59	140	3338	56	7000	28000	88	70	4450	38	7000	33900	86	
	VF 250_30	30	53	93	3000	34	7000	33400	86	47	4000	23	7000	40600	84	
	VF 250_40	40	41	70	3600	32	4680	36200	82	35	4800	22	—	44000	79	
	VF 250_50	50	36	56	3375	25	6370	39500	79	28.0	4500	17.0	—	47000	76	
	VF 250_60	60	38	47	3375	20.6	7000	42100	80	23.3	4500	15.0	—	47000	76	
	VF 250_80	80	32	35	2925	14.1	7000	47000	76	17.5	3900	10.0	—	47000	71	
	VF 250_100	100	29	28	2738	11.0	7000	47000	73	14.0	3650	7.8	3010	47000	68	
				n ₁ = 900 min ⁻¹					n ₁ = 500 min ⁻¹							
VF 250	VF 250_7	7	71	129	4150	63	7000	23700	90	71	5200	44	7000	27600	88	166
	VF 250_10	10	69	90	4800	51	7000	27600	89	50	6000	36	7000	32300	87	
	VF 250_15	15	64	60	5300	39	7000	33200	87	33	6400	27	7000	39500	85	
	VF 250_20	20	59	45	5950	33	1640	37200	85	25.0	7100	24	1910	44400	82	
	VF 250_30	30	53	30.0	5500	21	7000	44900	81	16.7	6000	14.7	7000	52000	79	
	VF 250_40	40	41	22.5	6500	20.0	—	48800	76	12.5	7000	13.6	—	52000	72	
	VF 250_50	50	36	18.0	6200	16.2	—	50000	73	10.0	6500	11.1	—	52000	68	
	VF 250_60	60	38	15.0	5600	12.2	—	50000	72	8.3	6300	8.6	4350	52000	68	
	VF 250_80	80	32	11.3	5200	9.3	—	50000	67	6.3	5400	6.8	7000	52000	62	
	VF 250_100	100	29	9.0	4800	7.2	3010	50000	63	5.0	5000	5.3	4160	52000	58	

9000 Nm

				n ₁ = 2800 min ⁻¹					n ₁ = 1400 min ⁻¹							
				n ₂	M _{n2}	P _{n1}	R _{n1}	R _{n2}	η _d	n ₂	M _{n2}	P _{n1}	R _{n1}		R _{n2}	η _d
				min ⁻¹	Nm	kW	N	N	%	min ⁻¹	Nm	kW	N		N	%
VFR 250	VFR 250_30	30	68	93	4800	54	2800	27800	89	47	6000	34	3500	34000	86	167
	VFR 250_45	45	63	62	5300	41	2800	33300	87	31	6400	25	3500	41300	84	
	VFR 250_60	60	58	47	5950	35	2800	37200	85	23.0	7100	21	3500	46100	81	
	VFR 250_90	90	52	31	5500	22	2800	44700	81	15.6	6000	12.6	3500	52000	78	
	VFR 250_120	120	40	23.3	6500	21.3	2800	48500	76	11.7	7000	12.1	3500	52000	71	
	VFR 250_150	150	35	18.7	6200	16.9	2800	50000	73	9.3	6500	9.5	3500	52000	67	
	VFR 250_180	180	37	15.6	5600	12.9	2800	50000	72	7.8	6300	7.7	3500	52000	67	
	VFR 250_240	240	31	11.7	5200	9.7	2800	50000	67	5.8	5400	5.4	3500	52000	61	
	VFR 250_300	300	28	9.3	4800	7.6	2800	50000	63	4.7	5000	4.3	3500	52000	57	
					n ₁ = 900 min ⁻¹					n ₁ = 500 min ⁻¹						
VFR 250	VFR 250_30	30	68	30.0	6500	24	3700	39600	84	16.7	7600	16.1	4200	47600	83	167
	VFR 250_45	45	63	20.0	6800	17.5	3700	48000	82	11.1	7900	11.6	3500	52000	80	
	VFR 250_60	60	58	15.0	7600	15.2	3700	52000	79	8.3	8600	9.9	3500	52000	76	
	VFR 250_90	90	52	10.0	6500	9.3	3700	52000	74	5.6	7400	6.1	3500	52000	71	
	VFR 250_120	120	40	7.5	7500	8.8	3700	52000	67	4.2	9000	6.2	3500	52000	64	
	VFR 250_150	150	35	6.0	7000	7.0	3700	52000	63	3.3	8600	5.1	3500	52000	59	
	VFR 250_180	180	37	5.0	6700	5.7	3700	52000	62	2.8	7600	3.8	3500	52000	59	
	VFR 250_240	240	31	3.8	5800	4.1	3700	52000	56	2.1	6500	2.7	3500	52000	52	
VFR 250_300	300	28	3.0	5300	3.2	3700	52000	52	1.7	6000	2.2	3500	52000	48		

(-) Nehmen Sie bitte Kontakt mit unserem Applikationsdienst und Querkraftsdaten angeben (Drehrichtung, Orientierung, Anordnung)



23 KOMBINATION DER VERHÄLTNISSSE IN DEN GETRIEBEN DER SERIE VF/VF, VF/W, W/VF

	Verhältnisse										i max	
	245	350	420	560	700	840	1120	1680	2100			
VF/VF 30/44												6000
VF 30	7	10	15	20	20	30	40	60	60			60
VF 44	35	35	28	28	35	28	28	28	35			100
VF/VF 30/49	240	315	420	540	720	900	1120	1440	2160	2700		6000
VF 30	10	7	15	15	20	20	40	40	60	60		60
VF 49	24	45	28	36	36	45	28	36	36	45		100
VF/W 30/63	240	315	450	570	720	900	1200	1520	2280	2700		7000
VF 30	10	7	15	15	30	30	40	40	60	60		70
W 63	24	45	30	38	24	30	30	38	38	45		100
VF/W 44/75	250	300	400	525	700	920	1200	1500	2100	2800		10000
VF 44	10	10	10	35	35	46	60	60	70	70		100
W 75	25	30	40	15	20	20	20	25	30	40		100
VF/W 44/86	230	300	400	525	700	920	1380	1840	2116	2760		10000
VF 44	10	10	10	35	35	46	46	46	46	60		100
W 86	23	30	40	15	20	20	30	40	46	46		100
VF/W 49/110	230	300	400	540	720	1080	1350	1656	2070	2800		10000
VF 49	10	10	10	18	36	36	45	36	45	70		100
W 110	23	30	40	30	20	30	30	46	46	40		100
W/VF 63/130	280	400	600	760	960	1200	1520	1800	2560	3200		10000
W 63	7	10	15	19	24	30	38	45	64	80		100
VF 130	40	40	40	40	40	40	40	40	40	40		100
W/VF 86/150	200	225	300	345	460	529	690	920	1380	1840	2944	10000
W 86	10	15	15	15	20	23	23	23	46	46	64	100
VF 150	20	15	20	23	23	23	30	40	30	40	46	100
W/VF 86/185	280	400	600	800	920	1200	1600	1840	2560	3200		10000
W 86	7	10	15	20	23	30	40	46	64	80		100
VF 185	40	40	40	40	40	40	40	40	40	40		100
VF/VF 130/210	280	400	600	800	920	1200	1600	1840	2560	3200		10000
VF 130	7	10	15	20	23	30	40	46	64	80		100
VF 210	40	40	40	40	40	40	40	40	40	40		100
VF/VF 130/250	280	400	600	800	920	1200	1600	1840	2560	3200		10000
VF 130	7	10	15	20	23	30	40	46	64	80		100
VF 250	40	40	40	40	40	40	40	40	40	40		100

Die Untersetzungskombinationen in dieser Tabelle sind die empfehlende Kombinationen von Herstellern.

Die technische Abteilung von Bonfiglioli könnte die Möglichkeit prüfen, weitere Kombination zu realisieren aber diese Untersetzungskombinationen müssen einen Gesamtwert kleiner als die Max. Untersetzung in der Tabelle haben.



24 MOTOR ANBAUMÖGLICHKEITEN

24.1 Motoren nach IEC-Standard

In den Tabellen werden die von den Größen her gesehenen möglichen Passungen angegeben. Die angemessene Getriebewahl muss unter Befolgung der im Paragraph: „Antriebsauswahl“ gegebenen Anleitungen und auf der Grundlage der Auswahltabelle der technischen Daten erfolgen.

 IEC	VF 27	VF 30	VF 44	VF 49	W 63	W 75	W 86	W 110	VF 130	VF 150	VF 185	VF 210	VF 250
P27 —	7...70	—	—	—	—	—	—	—	—	—	—	—	—
P56 $\frac{B5}{B14}$	—	7...70	—	—	—	—	—	—	—	—	—	—	—
P63 $\frac{B5}{B14}$	—	7...60	7...100	7...100	—	—	—	—	—	—	—	—	—
P71 $\frac{B5}{B14}$	—	—	7...35	7...60	7...100	$\frac{7...100}{—}$	$\frac{7...100}{—}$	—	—	—	—	—	—
P80 $\frac{B5}{B14}$	—	—	—	7...28	7...100	7...100	7...100	7...100	—	—	—	—	—
P90 $\frac{B5}{B14}$	—	—	—	—	7...30	7...100	7...100	7...100	$\frac{46...100}{—}$	—	—	—	—
P100 $\frac{B5}{B14}$	—	—	—	—	—	7...100	7...100	7...100	$\frac{7...80}{—}$	$\frac{23...100}{—}$	$\frac{50...100}{—}$	—	—
P112 $\frac{B5}{B14}$	—	—	—	—	—	7...100	7...100	7...100	$\frac{7...40}{—}$	$\frac{23...100}{—}$	$\frac{50...100}{—}$	—	—
P132 B5	—	—	—	—	—	—	—	7...100	7...40 #	7...46	30...80	7...100	7...100
P160 B5	—	—	—	—	—	—	—	—	—	7...20 #	15...40	7...100	7...100
P180 B5	—	—	—	—	—	—	—	—	—	—	7...20 #	7...100	7...100
P200 B5	—	—	—	—	—	—	—	—	—	—	—	7...100	7...100
P225 B5	—	—	—	—	—	—	—	—	—	—	—	7...100	7...100

 IEC	VFR 44	VFR 49	WR 63	WR 75	WR 86	WR 110	VFR 130	VFR 150	VFR 185	VFR 210	VFR 250
S44 —	70...500	—	—	—	—	—	—	—	—	—	—
P63 B5	—	30...300	21...300	21...300	21...300	—	—	—	—	—	—
P71 B5	—	—	21...300	21...300	21...300	21...300	—	—	—	—	—
P80 B5	—	—	—	21...300	21...300	21...300	30...300	—	—	—	—
P90 B5	—	—	—	15...150	15...150	21...300	30...300	30...300	30...300	—	—
P100 B5	—	—	—	—	—	21...300	30...300 #	30...300	30...300	30...300	30...300
P112 B5	—	—	—	—	—	21...300	30...300 #	30...300	30...300	30...300	30...300
P132 B5	—	—	—	—	—	—	—	25...50 #	25...100 #	30...300	30...300

■ Untersetzung der Vorstufe $i = 1.5$

Motorgetriebe-Kombinationen durch [#] gekennzeichnet und werden mit abgeflachten Keilnut entwickelt, die gemeinsam mit den Getriebe geliefert werden.



IEC		VF/VF 30/44	VF/VF 30/49	VF/W 30/63	VF/W 44/75	VF/W 44/86	VF/W 49/110	W/VF 63/130	W/VF 86/150	W/VF 86/185	VF/VF 130/210	VF/VF 130/250
P56	$\frac{B5}{B14}$	245...2100	240...2700	240...2700	—	—	—	—	—	—	—	—
P63	$\frac{B5}{B14}$	245...2100	240...2700	240...2700	250...2800	230...2760	230...2800	—	—	—	—	—
P71	$\frac{B5}{B14}$	—	—	—	250...700	230...700	230...2400	280...3200	$\frac{200...2944}{—}$	$\frac{280...3200}{—}$	—	—
P80	$\frac{B5}{B14}$	—	—	—	—	—	230...540	280...3200	200...2944	280...3200	—	—
P90	$\frac{B5}{B14}$	—	—	—	—	—	—	280...1200	200...2944	280...3200	$\frac{280...3200}{—}$	$\frac{280...3200}{—}$
P100	$\frac{B5}{B14}$	—	—	—	—	—	—	—	200...2944	280...3200	$\frac{280...3200}{—}$	$\frac{280...3200}{—}$
P112	$\frac{B5}{B14}$	—	—	—	—	—	—	—	200...2944	280...3200	$\frac{280...3200}{—}$	$\frac{280...3200}{—}$
P132	B5	—	—	—	—	—	—	—	—	—	280...1600 #	280...1600 #

Motorgetriebe-Kombinationen durch [#] gekennzeichnet und werden mit abgeflachten Keilnut entwickelt, die gemeinsam mit den Getriebe geliefert werden.

24.2 Kompaktmotor

	M1	M2 - ME2	ME3
W 63	7 ... 100	7 ... 100	⊖
W 75	7 ... 100	7 ... 100	7 ... 100
W 86	7 ... 100	7 ... 100	7 ... 100
W 110	⊖	7 ... 100	7 ... 100

	M1	ME2	ME3
W/VF 63/130	280 ... 3200	280 ... 3200	⊖
W/VF 86/150	200 ... 2944	200 ... 2944	200 ... 2944
W/VF 86/185	280 ... 3200	280 ... 3200	280 ... 3200

24.3 Nicht genormte Motoren

Für die Passung an nicht genormte Elektromotoren kann die Schnittstelle des Motors der zu den Serien VF und W gehörenden Getriebe mit der Kombination Antriebswelle/ Hybridflansch konfiguriert werden, die jedoch nicht der Richtlinie IEC entspricht. Die Kombination von Welle/ Flansch wird durch die jeweiligen Durchmesser gegeben und nachstehend aufgeführt.

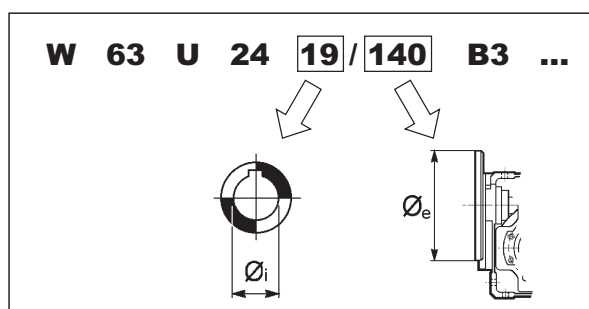

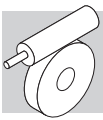

Die verfügbaren Kombinationen von Welle/Flansch und die Übersetzungsverhältnisse, auf die sie jeweils beschränkt sind, werden in den nachstehenden Tabelle angegeben.

		80	90	105	120	140	160	200
VF 30	9		$7 \leq i \leq 70$	⊖		$7 \leq i \leq 70$	⊖	⊖
	11	$7 \leq i \leq 60$		⊖	$7 \leq i \leq 60$		⊖	⊖
VF 44	HS	⊖	$7 \leq i \leq 100$	$7 \leq i \leq 100$	⊖	$7 \leq i \leq 100$	$7 \leq i \leq 100$	⊖
	11	⊖		$7 \leq i \leq 100$	⊖		$7 \leq i \leq 100$	⊖
	14	⊖	$7 \leq i \leq 35$		⊖	$7 \leq i \leq 35$		⊖
VF 49	HS	⊖	$7 \leq i \leq 100$	$7 \leq i \leq 100$	$7 \leq i \leq 100$	$7 \leq i \leq 100$	$7 \leq i \leq 100$	$7 \leq i \leq 100$
	11	⊖		$7 \leq i \leq 100$	$7 \leq i \leq 100$		$7 \leq i \leq 100$	$7 \leq i \leq 100$
	14	⊖	$7 \leq i \leq 60$		$7 \leq i \leq 60$	$7 \leq i \leq 60$		$7 \leq i \leq 60$
	19	⊖	$7 \leq i \leq 28$	$7 \leq i \leq 28$		$7 \leq i \leq 28$	$7 \leq i \leq 28$	
W 63	19	⊖	⊖	⊖	⊖	$7 \leq i \leq 100$	⊖	
W 75	14	⊖	⊖	⊖	⊖	⊖		$7 \leq i \leq 100$
	19	⊖	⊖	⊖		$7 \leq i \leq 100$	$7 \leq i \leq 100$	
	24	⊖	⊖	⊖	$7 \leq i \leq 100$		$7 \leq i \leq 100$	
W 86	14	⊖	⊖	⊖	⊖	⊖		$7 \leq i \leq 100$
	19	⊖	⊖	⊖		$7 \leq i \leq 100$	$7 \leq i \leq 100$	
	24	⊖	⊖	⊖	$7 \leq i \leq 100$		$7 \leq i \leq 100$	
W 110	19	⊖	⊖	⊖		$7 \leq i \leq 100$	⊖	⊖
	24	⊖	⊖	⊖	$7 \leq i \leq 100$		⊖	⊖

Standard-Passung

Einige Hybridkombinationen von Welle/Flansch sind auch bei den Getrieben VF mit einem Achsenabstand von 130 und mehr realisierbar.

In diesem Fall bitten wir Sie jedoch, sich hinsichtlich der Verfügbarkeit mit dem Technischen Service der Bonfiglioli in Verbindung zu setzen.

Die aus den vorstehenden Tabelle resultierenden Konfigurationen sind, ausschließlich in Bezug auf die geometrische Kompatibilität, als Möglichkeiten zu verstehen.

Die mechanische Kompatibilität der Einheit aus Motor-Getriebe muss anhand der üblichen Auswahlta-bellen im Hinblick auf Leistung/ Drehzahl geprüft werden.

Insbesondere sind solche Motorpassungen zu vermeiden, die Sicherheitsfaktoren von $S < 0,9$ erzeugen.



25 TRÄGHEITSMOMENT

Die In den folgenden Tabellen angegebenen Trägheitsmomente J_r [Kgm²] beziehen sich auf die Getriebeantriebsachse. Um das Lesen der Tabellen zu erleichtern, werden folgende Symbole verwendet:

	<p>Die Werte beziehen sich dem Kompaktgetriebe, ohne Motor. Um das Gesamtträgheitsmoment des Getriebemotors zu ermitteln, muss nur das Trägheitsmoment des Getriebes mit dem Trägheitsmoment des entsprechenden Motors addiert werden (Wert Elektromotorenauswahltabellen entnehmen).</p>		<p>Nur Getriebe vorbereitet für IEC-Motor (IEC-Größe...).</p>
			<p>Dieses Symbol bezieht sich auf Getriebewerte.</p>

VF 27



		i	J ($\cdot 10^{-4}$) [kgm ²]				
			P27				HS
VF 27	VF 27_7	7	0.02	—	—	—	0.02
	VF 27_10	10	0.01	—	—	—	0.01
	VF 27_15	15	0.01	—	—	—	0.01
	VF 27_20	20	0.01	—	—	—	0.01
	VF 27_30	30	0.01	—	—	—	0.01
	VF 27_40	40	0.01	—	—	—	0.01
	VF 27_60	60	0.01	—	—	—	0.01
	VF 27_70	70	0.01	—	—	—	0.01

VF 30

		i	J ($\cdot 10^{-4}$) [kgm ²]				
			P56	P63			HS
VF 30	VF 30_7	7	0.08	0.07	—	—	0.04
	VF 30_10	10	0.07	0.06	—	—	0.03
	VF 30_15	15	0.07	0.06	—	—	0.03
	VF 30_20	20	0.06	0.06	—	—	0.03
	VF 30_30	30	0.06	0.06	—	—	0.03
	VF 30_40	40	0.06	0.06	—	—	0.03
	VF 30_60	60	0.06	0.05	—	—	0.02
	VF 30_70	70	0.06	—	—	—	0.02







VF 44 - VFR 44

		i	J ($\cdot 10^{-4}$) [kgm ²]					
			 S44	P63	P71	 HS		
VF 44	VF 44_7	7	—	0.29	0.27	—	—	0.18
	VF 44_10	10	—	0.24	0.22	—	—	0.14
	VF 44_14	14	—	0.23	0.21	—	—	0.12
	VF 44_20	20	—	0.19	0.18	—	—	0.09
	VF 44_28	28	—	0.21	0.19	—	—	0.11
	VF 44_35	35	—	0.19	0.18	—	—	0.09
	VF 44_46	46	—	0.18	—	—	—	0.08
	VF 44_60	60	—	0.17	—	—	—	0.07
	VF 44_70	70	—	0.17	—	—	—	0.07
	VF 44_100	100	—	0.17	—	—	—	0.07
VFR 44	VFR 44_70	70	0.21	—	—	—	—	—
	VFR 44_100	100	0.20	—	—	—	—	—
	VFR 44_140	140	0.20	—	—	—	—	—
	VFR 44_175	175	0.20	—	—	—	—	—
	VFR 44_230	230	0.20	—	—	—	—	—
	VFR 44_300	300	0.20	—	—	—	—	—
	VFR 44_350	350	0.20	—	—	—	—	—
	VFR 44_500	500	0.20	—	—	—	—	—





VF 49 - VFR 49

	i	J ($\cdot 10^{-4}$) [kgm ²]						
		P63	P71	  P80			  HS	
VF 49	VF 49_7	7	0.69	0.67	0.61	—	—	0.42
	VF 49_10	10	0.61	0.60	0.53	—	—	0.34
	VF 49_14	14	0.58	0.57	0.5	—	—	0.31
	VF 49_18	18	0.54	0.53	0.46	—	—	0.27
	VF 49_24	24	0.52	0.5	0.44	—	—	0.24
	VF 49_28	28	0.56	0.54	0.48	—	—	0.28
	VF 49_36	36	0.53	0.51	—	—	—	0.25
	VF 49_45	45	0.51	0.49	—	—	—	0.24
	VF 49_60	60	0.50	0.48	—	—	—	0.23
	VF 49_70	70	0.50	—	—	—	—	0.22
	VF 49_80	80	0.49	—	—	—	—	0.22
VF 49_100	100	0.49	—	—	—	—	0.22	
VFR 49	VFR 49_30	30	0.74	—	—	—	—	0.94
	VFR 49_42	42	0.73	—	—	—	—	0.93
	VFR 49_54	54	0.73	—	—	—	—	0.93
	VFR 49_72	72	0.73	—	—	—	—	0.93
	VFR 49_84	84	0.73	—	—	—	—	0.93
	VFR 49_108	108	0.73	—	—	—	—	0.93
	VFR 49_135	135	0.73	—	—	—	—	0.93
	VFR 49_180	180	0.73	—	—	—	—	0.93
	VFR 49_210	210	0.72	—	—	—	—	0.92
	VFR 49_240	240	0.72	—	—	—	—	0.92
	VFR 49_300	300	0.72	—	—	—	—	0.92



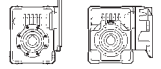



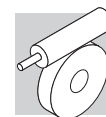

W 63 - WR 63

		i	J ($\cdot 10^{-4}$) [kgm ²]									
												
			S1	S2	S3	P63	P71	P80	P90			HS
W 63	W 63_7	7	3.4	3.6	—	—	3.5	3.5	3.5	—	—	3.6
	W 63_10	10	3.1	3.3	—	—	3.2	3.3	3.2	—	—	3.3
	W 63_12	12	3.1	3.3	—	—	3.1	3.2	3.1	—	—	3.3
	W 63_15	15	3.0	3.2	—	—	3.0	3.1	3.0	—	—	3.2
	W 63_19	19	2.9	3.1	—	—	2.9	3.0	2.9	—	—	3.1
	W 63_24	24	2.8	3.1	—	—	2.9	3.0	2.9	—	—	3.0
	W 63_30	30	2.9	3.1	—	—	2.9	3.0	2.9	—	—	3.1
	W 63_38	38	2.8	3.1	—	—	2.9	3.0	2.9	—	—	3.0
	W 63_45	45	2.8	3.0	—	—	2.9	2.9	2.9	—	—	3.0
	W 63_64	64	2.8	3.0	—	—	2.8	2.9	2.8	—	—	3.0
	W 63_80	80	2.8	3.0	—	—	2.8	2.9	2.8	—	—	3.0
W 63_100	100	2.8	3.0	—	—	2.8	2.9	2.8	—	—	2.9	
WR 63	WR 63_21	21	—	—	—	0.84	0.83	—	—	—	—	0.81
	WR 63_30	30	—	—	—	0.81	0.80	—	—	—	—	0.78
	WR 63_36	36	—	—	—	0.81	0.80	—	—	—	—	0.77
	WR 63_45	45	—	—	—	0.80	0.79	—	—	—	—	0.76
	WR 63_57	57	—	—	—	0.79	0.78	—	—	—	—	0.75
	WR 63_72	72	—	—	—	0.78	0.77	—	—	—	—	0.74
	WR 63_90	90	—	—	—	0.79	0.78	—	—	—	—	0.75
	WR 63_114	114	—	—	—	0.78	0.77	—	—	—	—	0.74
	WR 63_135	135	—	—	—	0.78	0.77	—	—	—	—	0.74
	WR 63_192	192	—	—	—	0.77	0.76	—	—	—	—	0.74
	WR 63_240	240	—	—	—	0.77	0.76	—	—	—	—	0.74
WR 63_300	300	—	—	—	0.77	0.76	—	—	—	—	0.73	



W 75 - WR 75







		i	J ($\cdot 10^{-4}$) [kgm ²]									
			 S1 S2 S3			  P63 P71 P80 P90 P100 P112						  HS
W 75	W 75_7	7	6.9	6.6	6.6	—	6.9	7.0	6.9	6.9	6.9	7.3
	W 75_10	10	6.4	6.1	6.1	—	6.4	6.4	6.3	5.7	5.7	6.8
	W 75_15	15	6.1	5.8	5.8	—	6.1	6.1	6.0	5.3	5.3	6.5
	W 75_20	20	5.9	5.6	5.6	—	5.9	5.9	5.9	5.2	5.2	6.3
	W 75_25	25	5.9	5.6	5.6	—	6.0	6.0	5.9	5.2	5.2	6.3
	W 75_30	30	5.9	5.6	5.6	—	5.9	5.9	5.9	5.2	5.2	6.3
	W 75_40	40	5.9	5.6	5.6	—	5.9	5.9	5.8	5.2	5.2	6.3
	W 75_50	50	5.9	5.6	5.6	—	5.9	5.9	5.8	5.1	5.1	6.2
	W 75_60	60	5.8	5.5	5.5	—	5.8	5.9	5.8	5.1	5.1	6.2
	W 75_80	80	5.8	5.5	5.5	—	5.8	5.8	5.8	5.1	5.1	6.2
W 75_100	100	5.8	5.5	5.5	—	5.8	5.8	5.7	5.0	5.0	6.2	
WR 75	WR 75_21	21	—	—	—	1.2	1.2	2.1	—	—	—	1.9
	WR 75_30	30	—	—	—	1.1	1.1	2.1	—	—	—	1.1
	WR 75_45	45	—	—	—	1.1	1.1	2.0	—	—	—	1.1
	WR 75_60	60	—	—	—	1.1	1.1	2.0	—	—	—	1.0
	WR 75_75	75	—	—	—	1.1	1.1	2.0	—	—	—	1.0
	WR 75_90	90	—	—	—	1.1	1.1	2.0	—	—	—	1.0
	WR 75_120	120	—	—	—	1.1	1.1	2.0	—	—	—	1.0
	WR 75_150	150	—	—	—	1.1	1.1	2.0	—	—	—	1.0
	WR 75_180	180	—	—	—	1.1	1.1	2.0	—	—	—	1.0
	WR 75_240	240	—	—	—	1.1	1.1	2.0	—	—	—	1.0
WR 75_300	300	—	—	—	1.1	1.1	2.0	—	—	—	1.0	

		J ($\cdot 10^{-4}$) [kgm ²]	
		i	 P90

WR 75_P90 B5	WR 75_15	15	6.0
	WR 75_22.5	22.5	5.9
	WR 75_30	30	5.8
	WR 75_37.5	37.5	5.8
	WR 75_45	45	5.8
	WR 75_60	60	5.8
WR 75_75	75	5.8	



W 86 - WR 86

		i	J ($\cdot 10^{-4}$) [kgm ²]									HS
			 S1	 S2	S3	 P63	 P71	 P80	 P90	 P100		
W 86	W 86_7	7	9.7	9.4	9.4	—	9.7	9.7	9.6	9.6	—	10.1
	W 86_10	10	8.4	8.1	8.1	—	8.4	8.4	8.3	7.7	—	8.9
	W 86_15	15	7.7	7.4	7.4	—	7.7	7.7	7.7	7.0	—	8.2
	W 86_20	20	6.9	6.6	6.6	—	6.9	7.0	6.9	6.2	—	7.4
	W 86_23	23	6.8	6.5	6.5	—	6.8	6.9	6.8	6.1	—	7.3
	W 86_30	30	7.3	7.0	7.0	—	7.3	7.3	7.3	6.6	—	7.8
	W 86_40	40	6.7	6.4	6.4	—	6.7	6.7	6.6	6.0	—	7.2
	W 86_46	46	6.7	6.4	6.4	—	6.7	6.7	6.6	5.9	—	7.1
	W 86_56	56	6.6	6.3	6.3	—	6.6	6.7	6.6	5.9	—	7.1
	W 86_64	64	6.6	6.3	6.3	—	6.6	6.6	6.5	5.9	—	7.1
	W 86_80	80	6.6	6.3	6.3	—	6.6	6.6	6.5	5.9	—	7.1
W 86_100	100	6.4	6.1	6.1	—	6.4	6.5	6.4	5.7	—	6.9	
WR 86	WR 86_21	21	—	—	—	1.5	1.5	2.4	—	—	—	2.2
	WR 86_30	30	—	—	—	1.4	1.3	2.3	—	—	—	1.3
	WR 86_45	45	—	—	—	1.3	1.3	2.2	—	—	—	1.2
	WR 86_60	60	—	—	—	1.2	1.2	2.1	—	—	—	1.2
	WR 86_69	69	—	—	—	1.2	1.2	2.1	—	—	—	1.1
	WR 86_90	90	—	—	—	1.2	1.2	2.2	—	—	—	1.2
	WR 86_120	120	—	—	—	1.2	1.2	2.1	—	—	—	1.1
	WR 86_138	138	—	—	—	1.2	1.2	2.1	—	—	—	1.1
	WR 86_168	168	—	—	—	1.2	1.2	2.1	—	—	—	1.1
	WR 86_192	192	—	—	—	1.2	1.1	2.1	—	—	—	1.1
	WR 86_240	240	—	—	—	1.2	1.1	2.1	—	—	—	1.1
WR 86_300	300	—	—	—	1.1	1.1	2.1	—	—	—	1.1	

		i	J ($\cdot 10^{-4}$) [kgm ²]
			 P90
WR 86_P90 B5	WR 86_15	15	6.9
	WR 86_22.5	22.5	6.6
	WR 86_30	30	6.3
	WR 86_34.5	34.5	6.2
	WR 86_45	45	6.4
	WR 86_60	60	6.2
	WR 86_69	69	6.1
WR 86_84	84	6.1	

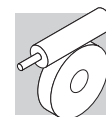

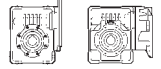

W 110 - WR 110

		i	J ($\cdot 10^{-4}$) [kgm ²]									HS
												
			S1	S2	S3	P63	P71	P80	P90	P100	P132	
W 110	W 110_7	7	—	22	22	—	—	23	23	23	28	23
	W 110_10	10	—	19	19	—	—	19	19	24	24	20
	W 110_15	15	—	17	17	—	—	17	17	22	22	17
	W 110_20	20	—	14	14	—	—	14	14	19	19	15
	W 110_23	23	—	14	14	—	—	14	14	19	19	15
	W 110_30	30	—	15	15	—	—	16	16	20	20	16
	W 110_40	40	—	13	13	—	—	14	14	19	19	14
	W 110_46	46	—	13	13	—	—	13	13	18	18	14
	W 110_56	56	—	13	13	—	—	13	13	18	18	14
	W 110_64	64	—	13	13	—	—	13	13	18	18	14
	W 110_80	80	—	13	13	—	—	13	13	18	18	14
W 110_100	100	—	13	13	—	—	13	13	18	18	14	
WR 110	WR 110_21	21	—	—	—	—	3.0	9.0	8.8	8.9	—	9.2
	WR 110_30	30	—	—	—	—	2.5	8.6	8.4	8.4	—	8.8
	WR 110_45	45	—	—	—	—	2.3	8.3	8.2	8.2	—	8.5
	WR 110_60	60	—	—	—	—	2.0	8.1	7.9	7.9	—	8.3
	WR 110_69	69	—	—	—	—	2.0	8.0	7.9	7.9	—	8.2
	WR 110_90	90	—	—	—	—	2.2	8.2	8.1	8.1	—	8.4
	WR 110_120	120	—	—	—	—	1.9	8.0	7.8	7.9	—	8.2
	WR 110_138	138	—	—	—	—	1.9	8.0	7.8	7.8	—	8.2
	WR 110_168	168	—	—	—	—	1.9	8.0	7.8	7.8	—	8.1
	WR 110_192	192	—	—	—	—	1.9	7.9	7.8	7.8	—	8.1
	WR 110_240	240	—	—	—	—	1.9	7.9	7.8	7.8	—	8.1
WR 110_300	300	—	—	—	—	1.9	7.9	7.8	7.8	—	8.1	



VF 130 - VFR 130

		i	J ($\cdot 10^{-4}$) [kgm ²]					HS
			P80	P90	 P100	 P112	P132	
VF 130	VF 130_7	7	—	—	36	36	35	31
	VF 130_10	10	—	—	27	27	25	22
	VF 130_15	15	—	—	20	20	18	15
	VF 130_20	20	—	—	17	17	15	11
	VF 130_23	23	—	—	16	16	14	11
	VF 130_30	30	—	—	17	17	15	12
	VF 130_40	40	—	—	15	15	14	9.9
	VF 130_46	46	—	14	14	—	—	8.2
	VF 130_56	56	—	13	13	—	—	7.8
	VF 130_64	64	—	13	13	—	—	7.4
	VF 130_80	80	—	13	12	—	—	7.0
	VF 130_100	100	—	13	—	—	—	8.9
VFR 130	VFR 130_30	30	5.3	5.3	5.2	5.2	—	5.7
	VFR 130_45	45	4.5	4.5	4.4	4.4	—	4.9
	VFR 130_60	60	4.2	4.1	4.1	4.1	—	4.6
	VFR 130_69	69	4.1	4.0	4.0	4.0	—	4.5
	VFR 130_90	90	4.2	4.1	4.1	4.1	—	4.6
	VFR 130_120	120	4.0	3.9	4.0	4.0	—	4.4
	VFR 130_138	138	3.8	3.8	3.7	3.7	—	4.2
	VFR 130_168	168	3.8	3.7	3.7	3.7	—	4.1
	VFR 130_192	192	3.7	3.7	3.6	3.6	—	4.1
	VFR 130_240	240	3.7	3.6	3.6	3.6	—	4.1
	VFR 130_300	300	3.9	3.8	3.8	3.8	—	4.3

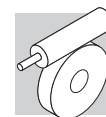



VF 150 - VFR 150

		i	J ($\cdot 10^{-4}$) [kgm ²]					HS
			P80	P90	 P100	P112	P132	
VF 150	VF 150_7	7	—	—	—	—	58	50
	VF 150_10	10	—	—	—	—	44	35
	VF 150_15	15	—	—	—	—	29	21
	VF 150_20	20	—	—	—	—	27	19
	VF 150_23	23	—	—	28	28	26	17
	VF 150_30	30	—	—	31	31	29	21
	VF 150_40	40	—	—	26	26	24	16
	VF 150_46	46	—	—	24	24	22	13
	VF 150_56	56	—	25	24	24	—	13
	VF 150_64	64	—	24	23	23	—	12
	VF 150_80	80	—	23	22	22	—	11
VF 150_100	100	—	23	22	22	—	11	
VFR 150	VFR 150_25	25	—	—	—	15	—	—
	VFR 150_30	30	10	10	10	—	—	11
	VFR 150_37.5	37.5	—	—	—	13	—	—
	VFR 150_45	45	8.8	8.8	8.8	—	—	9.7
	VFR 150_50	50	—	—	—	12	—	—
	VFR 150_60	60	8.4	8.3	8.3	—	—	9.2
	VFR 150_69	69	8.4	8.4	8.4	—	—	9.3
	VFR 150_90	90	8.3	8.7	8.7	—	—	9.7
	VFR 150_120	120	8.3	8.2	8.2	—	—	9.2
	VFR 150_138	138	8.0	7.9	7.9	—	—	8.9
	VFR 150_168	168	7.9	7.9	7.9	—	—	8.9
	VFR 150_192	192	7.9	7.8	7.8	—	—	8.8
	VFR 150_240	240	7.7	7.7	7.7	—	—	8.6
VFR 150_300	300	7.7	7.7	7.7	—	—	8.6	

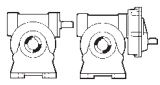

VF 185 - VFR 185

		i	J ($\cdot 10^{-4}$) [kgm ²]						
									
			P90	P100	P112	P132	P160	P180	HS
VF 185	VF 185_7	7	—	—	—	—	—	146	128
	VF 185_10	10	—	—	—	—	—	108	91
	VF 185_15	15	—	—	—	—	70	88	50
	VF 185_20	20	—	—	—	—	69	66	48
	VF 185_30	30	—	—	—	58	54	—	34
	VF 185_40	40	—	—	—	63	61	—	41
	VF 185_50	50	—	59	59	58	—	—	35
	VF 185_60	60	—	55	55	53	—	—	31
	VF 185_80	80	—	52	52	51	—	—	28
	VF 185_100	100	—	51	51	—	—	—	27
VFR 185	VFR 185_25	25	—	—	—	24	—	—	—
	VFR 185_37.5	37.5	—	—	—	17	—	—	—
	VFR 185_50	50	—	—	—	17	—	—	—
	VFR 185_75	75	—	—	—	15	—	—	—
	VFR 185_100	100	—	—	—	16	—	—	—
	VFR 185_30	30	17	17	17	—	—	—	18
	VFR 185_45	45	12	12	12	—	—	—	13
	VFR 185_60	60	12	12	12	—	—	—	13
	VFR 185_90	90	10	10	10	—	—	—	11
	VFR 185_120	120	11	11	11	—	—	—	12
	VFR 185_150	150	10	10	10	—	—	—	11
	VFR 185_180	180	9.9	9.9	9.9	—	—	—	11
	VFR 185_240	240	9.6	9.6	9.6	—	—	—	11
	VFR 185_300	300	9.5	9.4	9.4	—	—	—	10



VF 210 - VFR 210

		i	J ($\cdot 10^{-4}$) [kgm ²]							HS
			P100	P112	P132	P160	P180	P200	P225	
VF 210	VF 210_7	7	—	—	286	286	286	286	286	286
	VF 210_10	10	—	—	177	177	177	177	177	177
	VF 210_15	15	—	—	120	120	120	120	120	120
	VF 210_20	20	—	—	116	116	116	116	116	116
	VF 210_30	30	—	—	81	81	81	81	81	81
	VF 210_40	40	—	—	98	98	98	98	98	98
	VF 210_50	50	—	—	84	84	84	84	84	84
	VF 210_60	60	—	—	75	75	75	75	75	75
	VF 210_80	80	—	—	68	68	68	68	68	68
	VF 210_100	100	—	—	63	63	63	63	63	63
VFR 210	VFR 210_30	30	48	48	47	47	—	—	—	51
	VFR 210_45	45	41	41	41	41	—	—	—	45
	VFR 210_60	60	41	41	41	40	—	—	—	45
	VFR 210_90	90	37	37	37	36	—	—	—	41
	VFR 210_120	120	39	39	39	38	—	—	—	43
	VFR 210_150	150	37	37	37	37	—	—	—	41
	VFR 210_180	180	36	36	36	36	—	—	—	40
	VFR 210_240	240	36	36	36	35	—	—	—	39
	VFR 210_300	300	35	35	35	34	—	—	—	39



VF 250 - VFR 250



		i	J ($\cdot 10^{-4}$) [kgm ²]							
			P100	P112	P132	P160	P180	P200	P225	HS
VF 250	VF 250_7	7	—	—	620	620	620	620	620	620
	VF 250_10	10	—	—	387	387	387	387	387	387
	VF 250_15	15	—	—	266	266	266	266	266	266
	VF 250_20	20	—	—	242	242	242	242	242	242
	VF 250_30	30	—	—	184	184	184	184	184	184
	VF 250_40	40	—	—	241	241	241	241	241	241
	VF 250_50	50	—	—	240	240	240	240	240	240
	VF 250_60	60	—	—	158	158	158	158	158	158
	VF 250_80	80	—	—	160	160	160	160	160	160
	VF 250_100	100	—	—	149	149	149	149	149	149
VFR 250	VFR 250_30	30	71	71	71	70	—	—	—	75
	VFR 250_45	45	58	58	57	57	—	—	—	61
	VFR 250_60	60	55	55	55	54	—	—	—	58
	VFR 250_90	90	48	48	48	48	—	—	—	52
	VFR 250_120	120	55	55	54	54	—	—	—	58
	VFR 250_150	150	55	55	54	54	—	—	—	58
	VFR 250_180	180	46	46	45	45	—	—	—	49
	VFR 250_240	240	46	46	45	45	—	—	—	49
	VFR 250_300	300	45	45	44	44	—	—	—	48

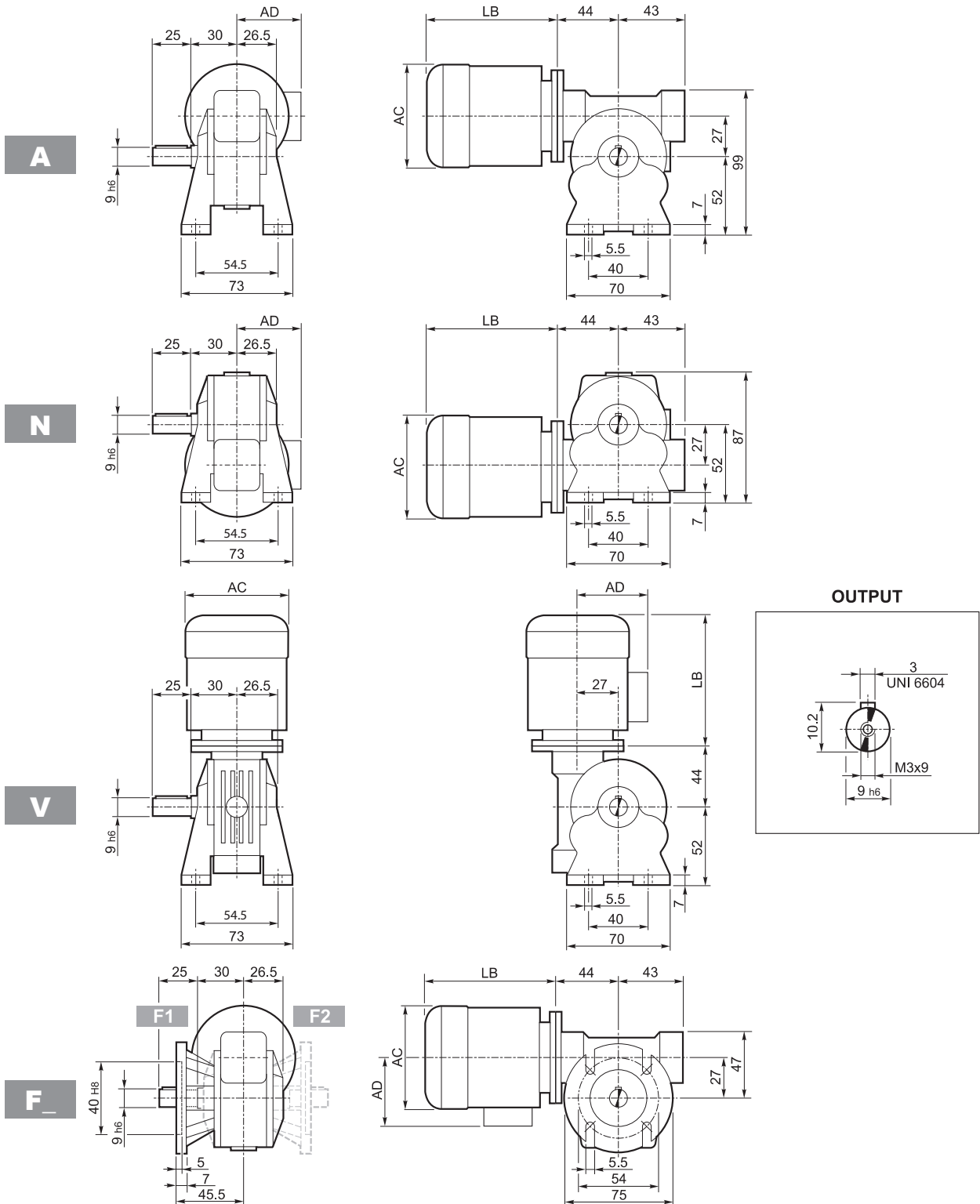

26 ABMESSUNGEN FÜR GETRIEBEMOTOREN UND GETRIEBEN VORBEREITET FÜR IEC-MOTOR

VF 27...BN27



	P_n kW	n min ⁻¹	M_n Nm	η %	$\text{COS}\phi$	I_n A (400V)	$\frac{I_s}{I_n}$	$\frac{M_s}{M_n}$	$\frac{M_a}{M_n}$	J_m ($\cdot 10^{-4}$) kgm ²	 Kg	LB	AC	AD
BN 27A4	0.04	1350	0.28	36	0.57	0.28	2.3	2.0	1.8	0.56	2.8	132	103	76
BN 27B4	0.06	1360	0.42	39	0.57	0.39	2.5	2.2	1.9	0.76	3.1	149	103	76
BN 27C4	0.09	1380	0.63	46	0.65	0.43	2.8	2.3	1.9	1.49	3.3	175	112	94

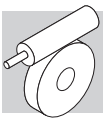

VF 30...P (IEC)

A

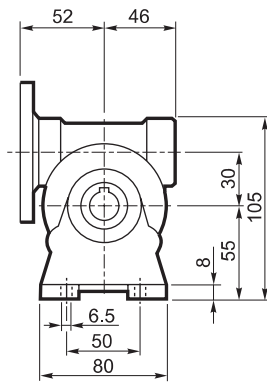
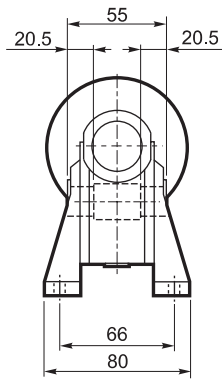

N

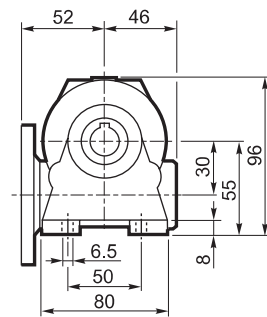
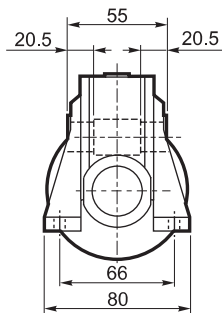

V

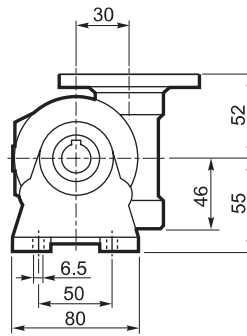
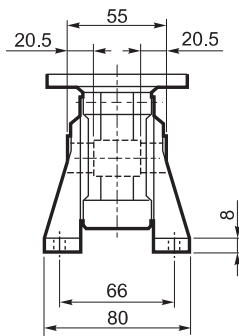

P

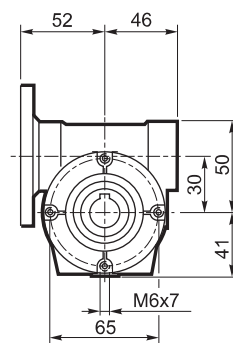
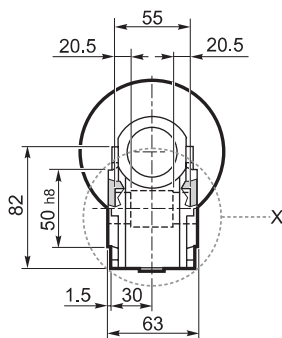

INPUT

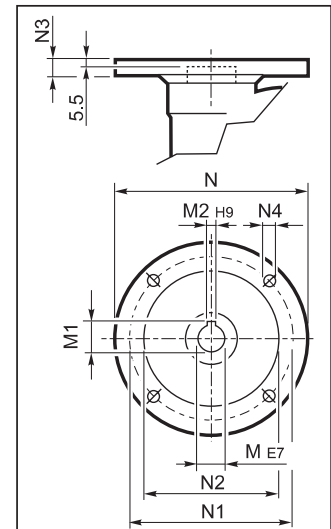

P56 B14

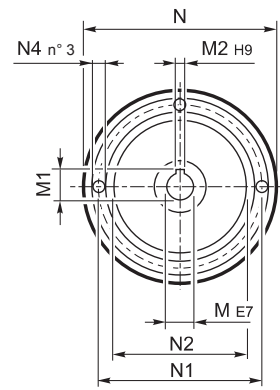

OUTPUT

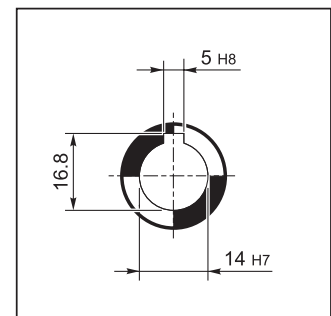

X

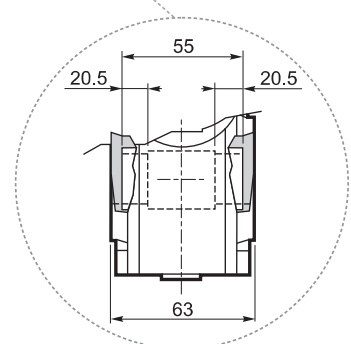

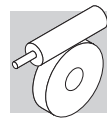

VF 30...P (IEC)

F

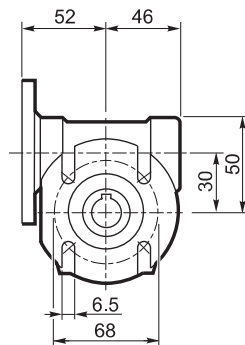
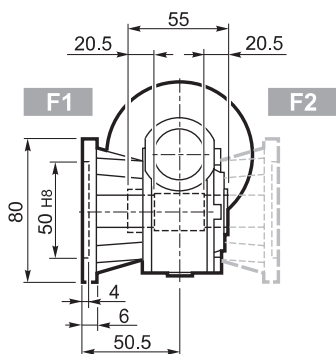

U

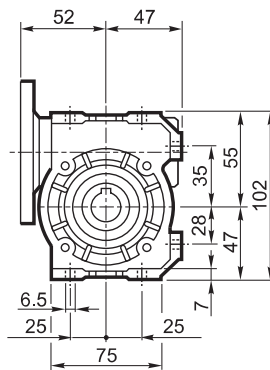
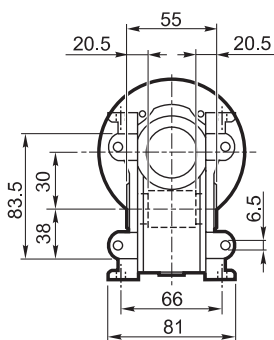

INPUT

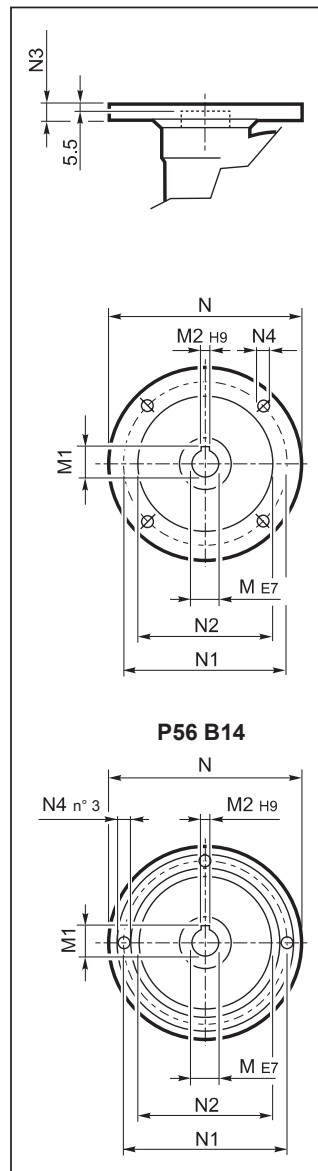

OUTPUT

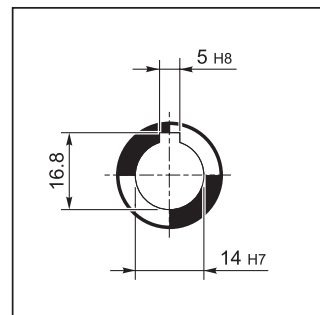

		M	M1	M2	N	N1	N2	N3	N4	
VF 30	P56 B5	9	10.4	3	120	100	80	7	7	1.1
VF 30	P56 B14	9	10.4	3	80	65	50	7	5.5	
VF 30	P63 B5	11	12.8	4	140	115	95	8	9.5	
VF 30	P63 B14	11	12.8	4	90	75	60	6	5.5	



VF 44...P (IEC)

A

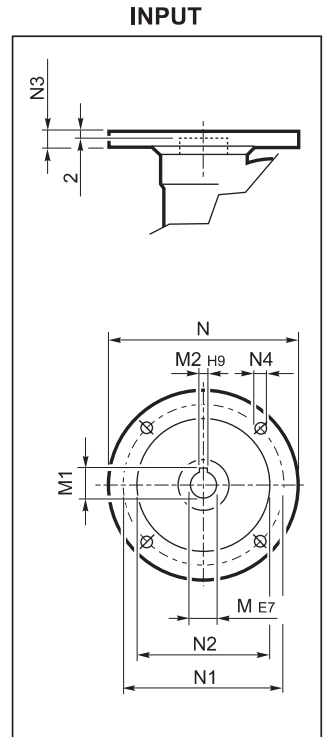
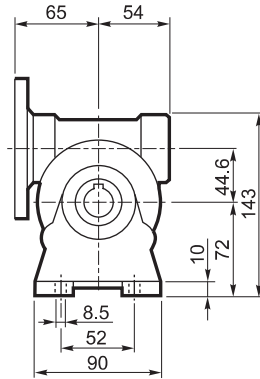
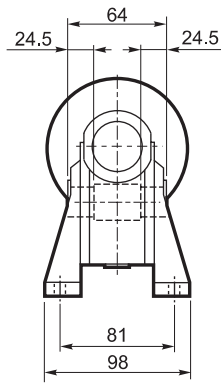

N

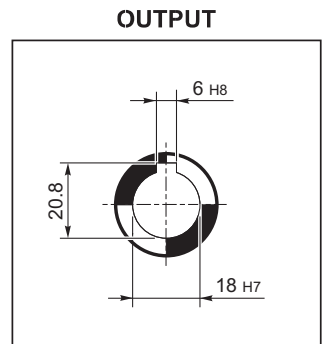
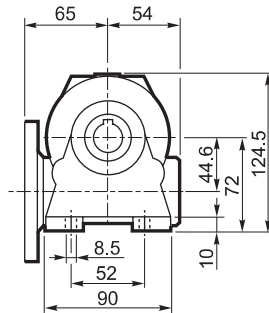
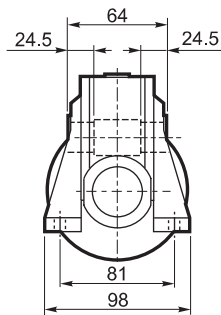

V

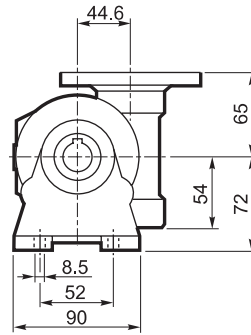
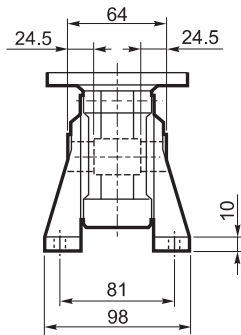

P

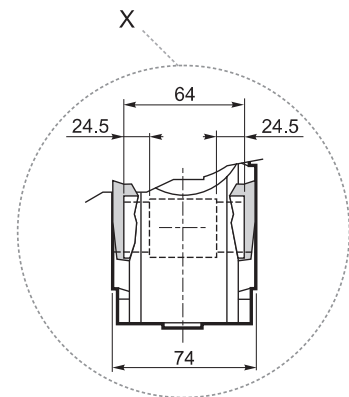
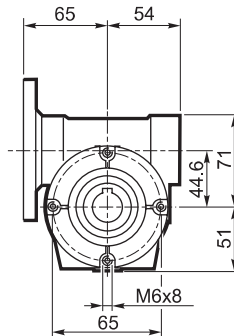
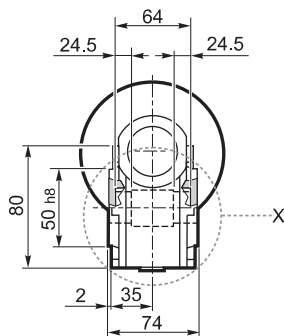



VF 44...P (IEC)

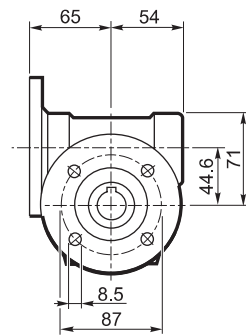
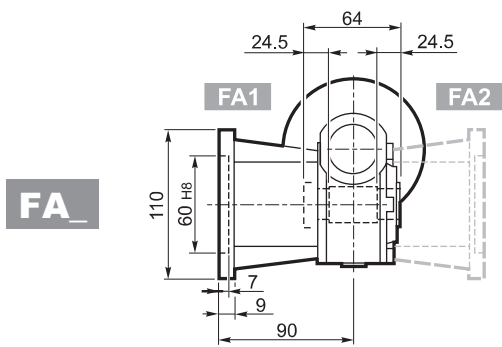
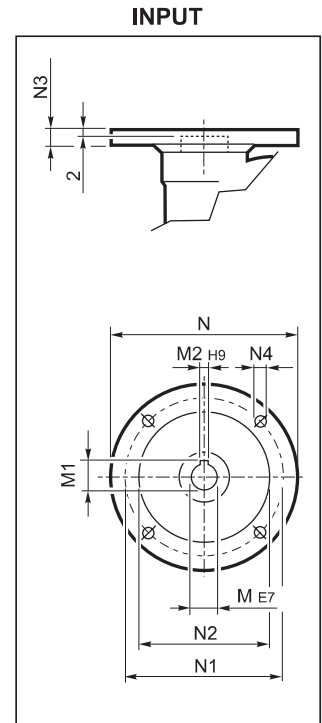
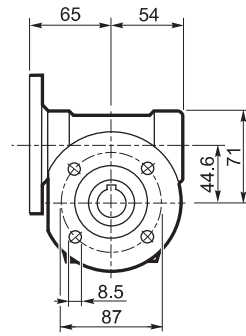
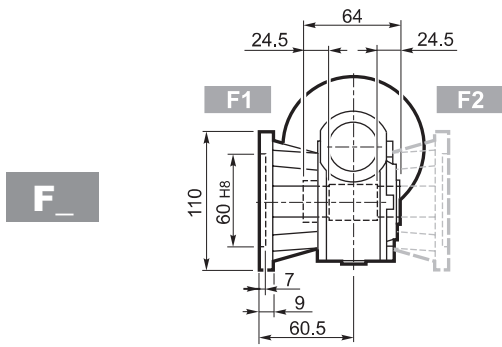

OUTPUT

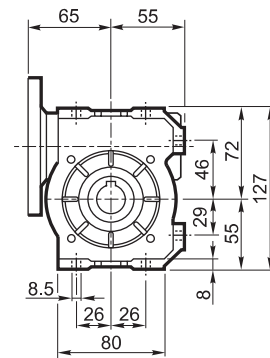
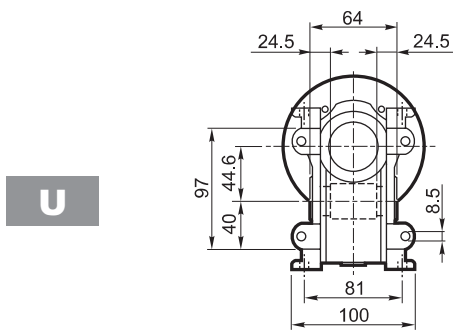
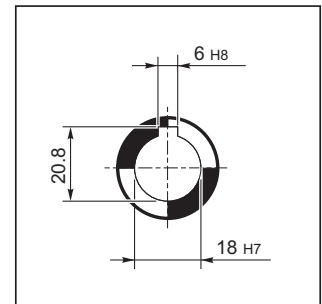

		M	M1	M2	N	N1	N2	N3	N4	
VF 44	P63 B5	11	12.8	4	140	115	95	10	9.5	2.0
VF 44	P71 B5	14	16.3	5	160	130	110	10	9.5	
VF 44	P63 B14	11	12.8	4	90	75	60	8	5.5	
VF 44	P71 B14	14	16.3	5	105	85	70	10	7	



VFR 44...BN 44

A

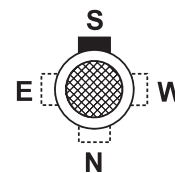
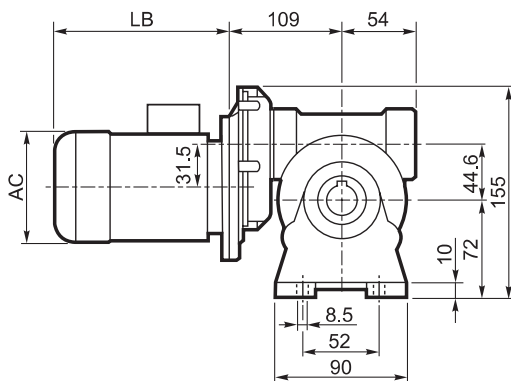
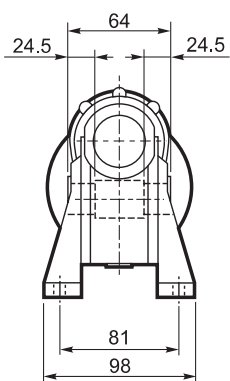

OUTPUT

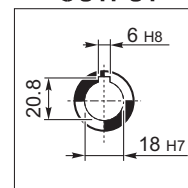

N

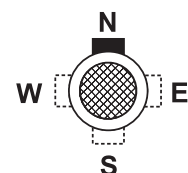
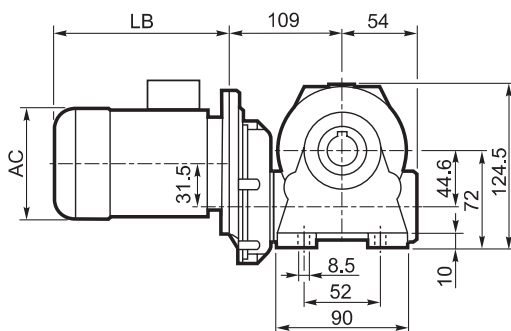
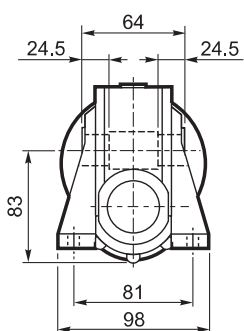

V

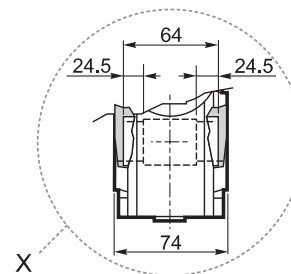
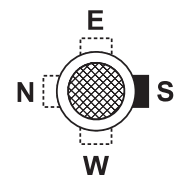
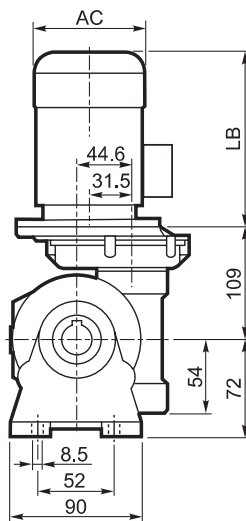
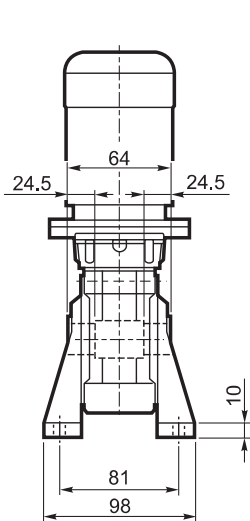

P

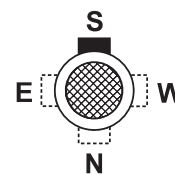
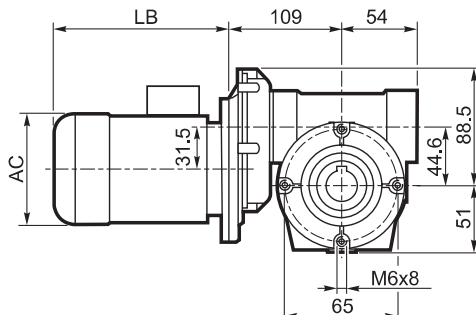
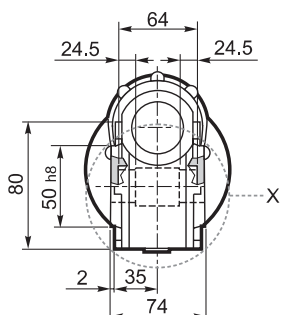



VFR 44...BN 44

F_

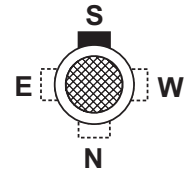
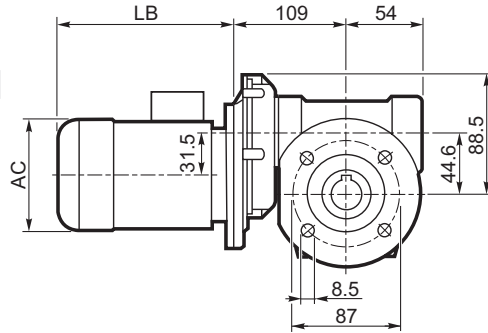
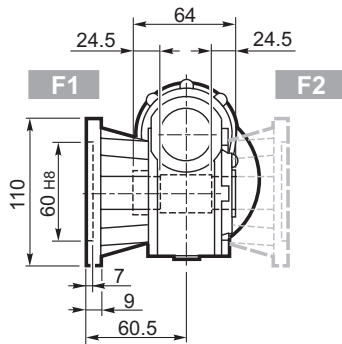

OUTPUT

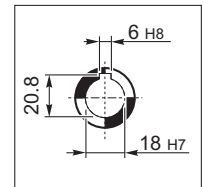

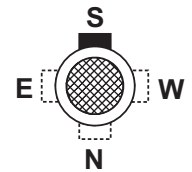
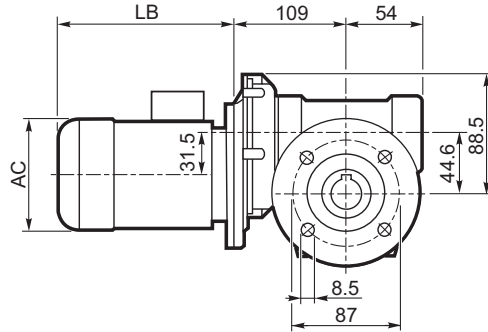
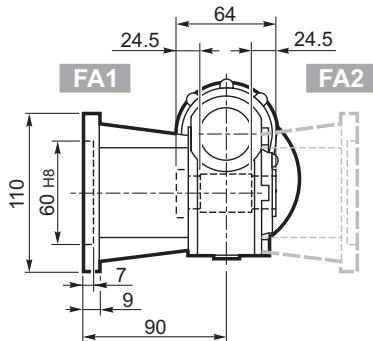

FA_

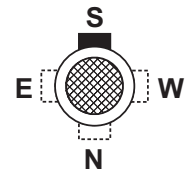
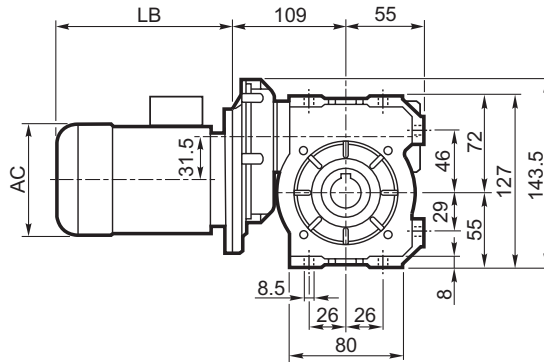
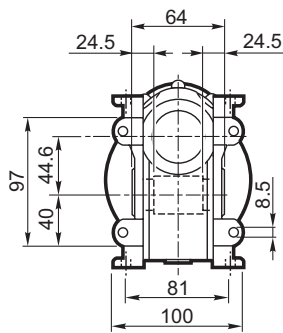

U



	P_n kW	n min ⁻¹	M_n Nm	η %	$\cos\phi$	I_n A (400V)	$\frac{I_s}{I_n}$	$\frac{M_s}{M_n}$	$\frac{M_a}{M_n}$	J_m ($\cdot 10^{-4}$) kgm ²		LB	AC	AD
BN 44B4	0.06	1380	0.42	40	0.58	0.38	2.4	2.3	1.9	1.22	4.7	168	112	94
BN 44C4	0.09	1380	0.63	46	0.65	0.43	2.8	2.3	2	1.49	4.6	168	112	94



VF/VF 30/44...P (IEC)

A

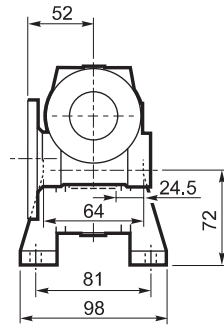
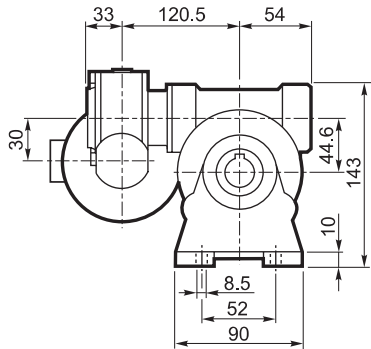

INPUT

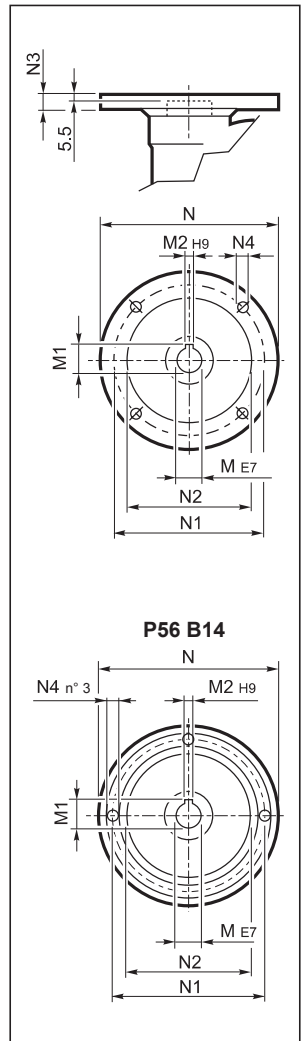

F

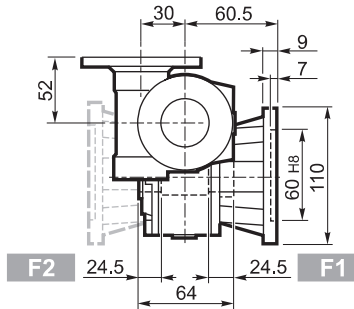
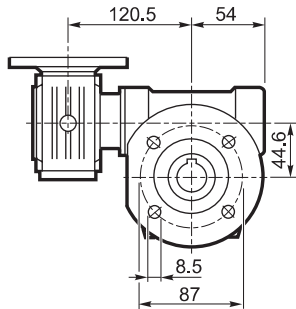

FA

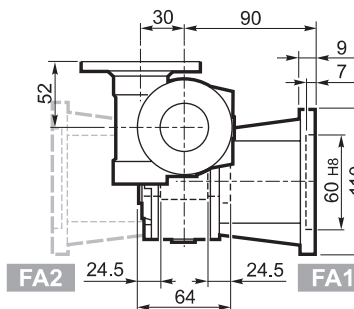
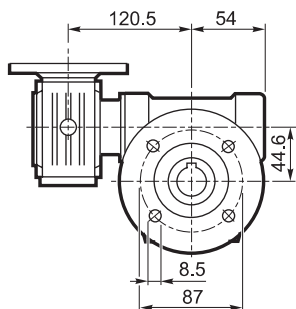

OUTPUT

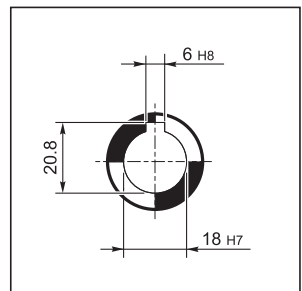



VF/VF 30/44...P (IEC)

P

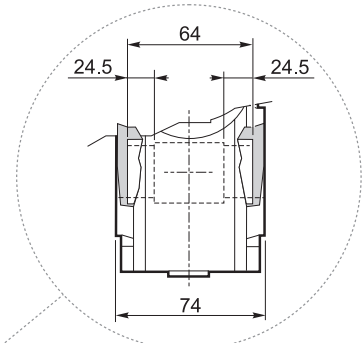
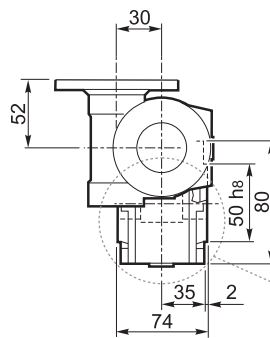
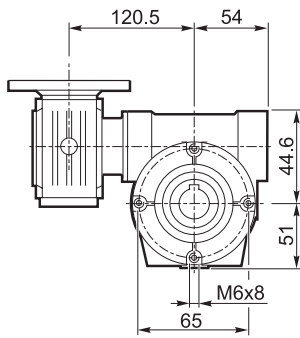

INPUT

U

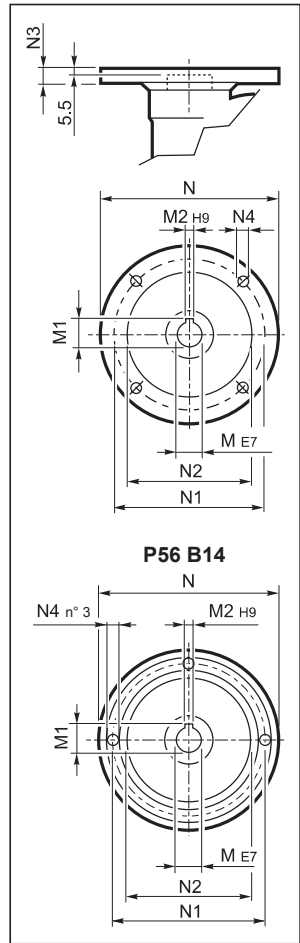
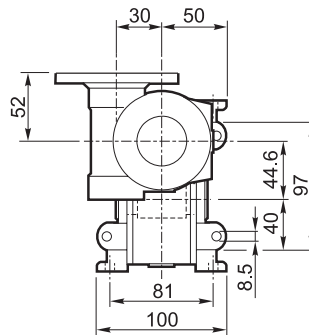
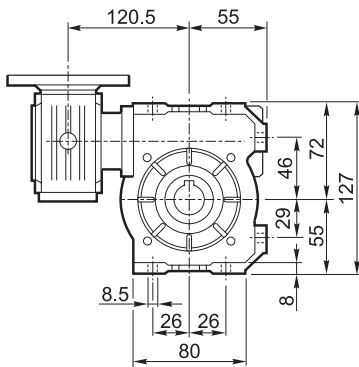

OUTPUT

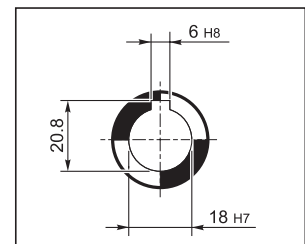

		M	M1	M2	N	N1	N2	N3	N4	
VF/VF 30/44	P56 B14	9	10.4	3	80	65	50	7	5.5	3.5
VF/VF 30/44	P63 B14	11	12.8	4	90	75	60	6	5.5	



VF 49...P (IEC)

A

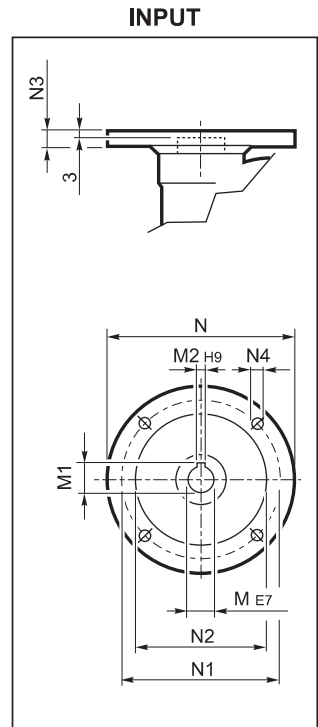
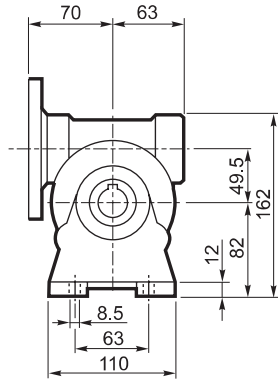
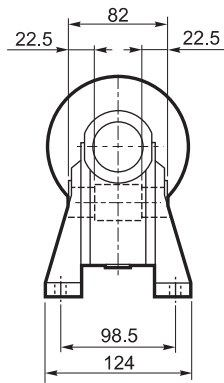

N

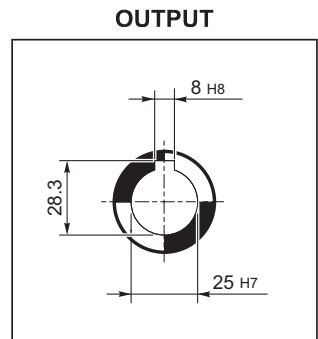
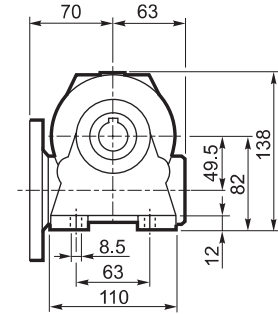
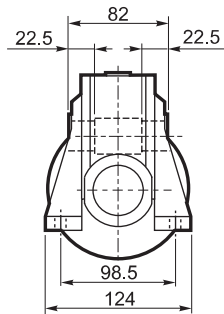

V

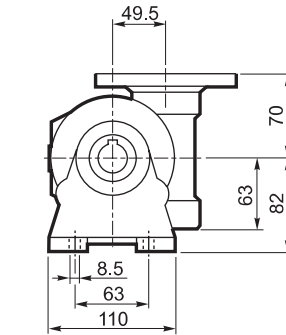
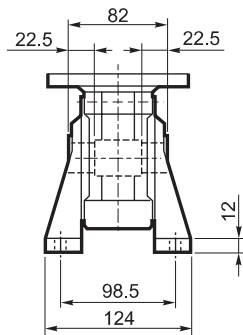

P

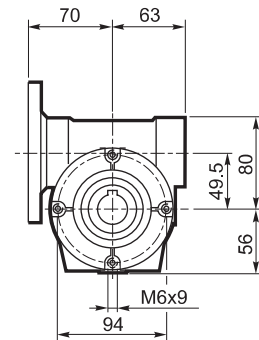
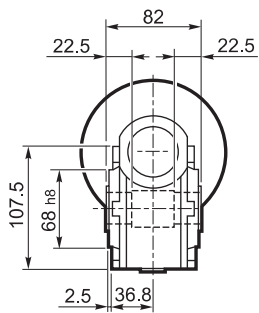



VF 49...P (IEC)

F_

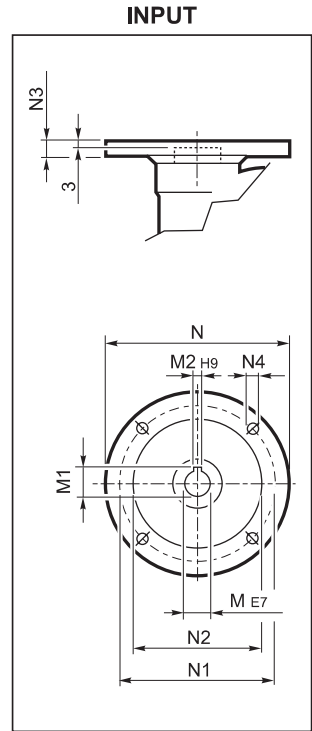
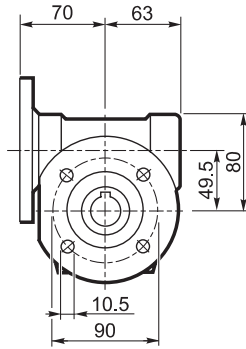
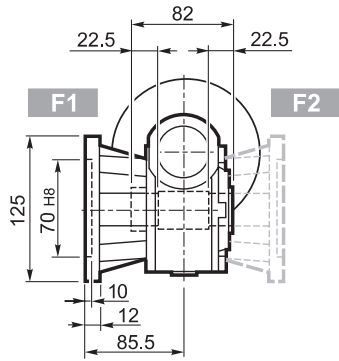

FA_

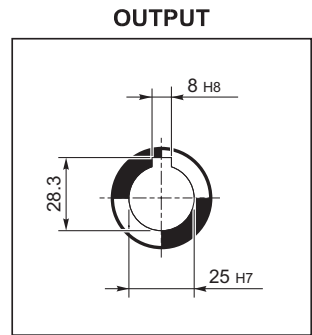
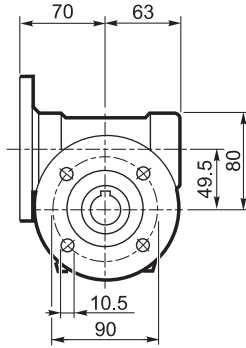
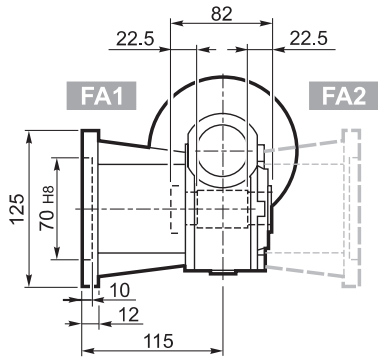

U

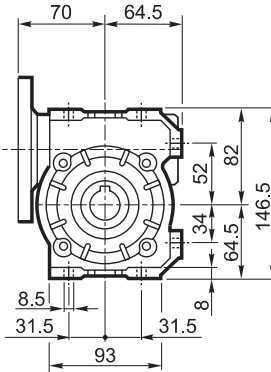
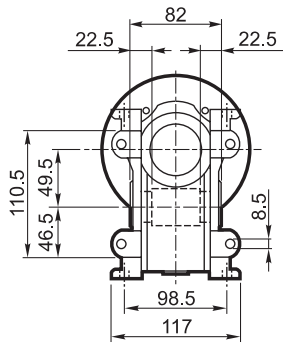

		M	M1	M2	N	N1	N2	N3	N4	
		11	12.8	4	140	115	95	10.5	9.5	3.0
VF 49	P71 B5	14	16.3	5	160	130	110	10.5	9.5	
VF 49	P80 B5	19	21.8	6	200	165	130	10	11.5	
VF 49	P63 B14	11	12.8	4	90	75	60	7	6	
VF 49	P71 B14	14	16.3	5	105	85	70	10.5	6.5	
VF 49	P80 B14	19	21.8	6	120	100	80	10	7	



VFR 49...P (IEC)

A

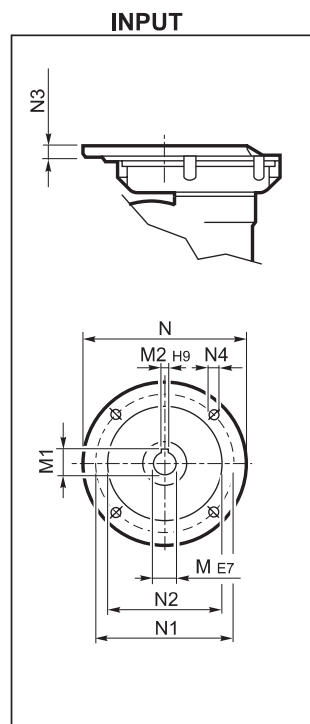
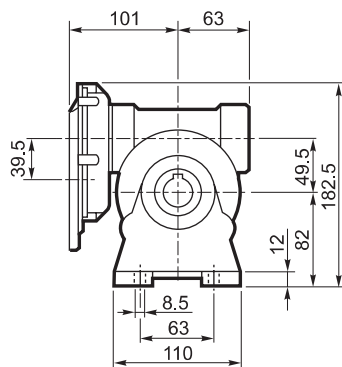
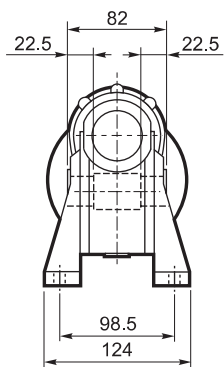

N

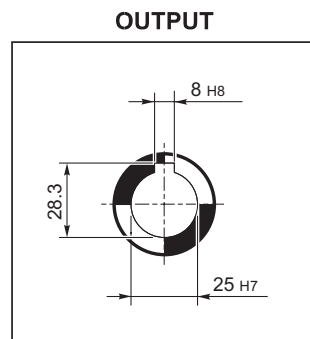
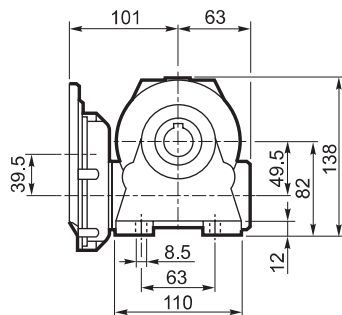
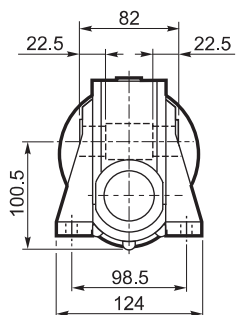

V

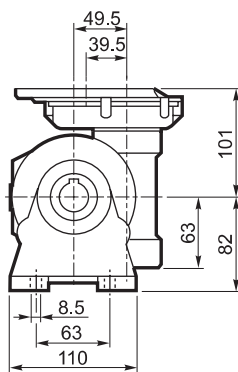
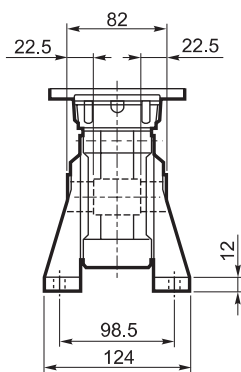

P

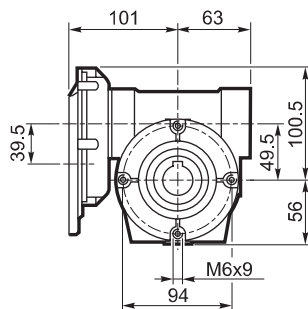
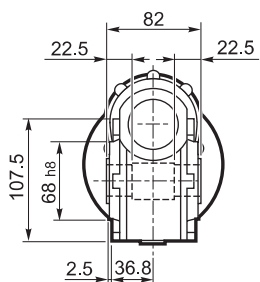



VFR 49...P (IEC)

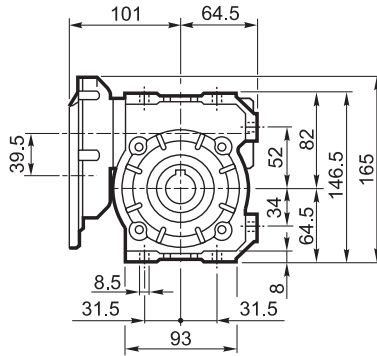
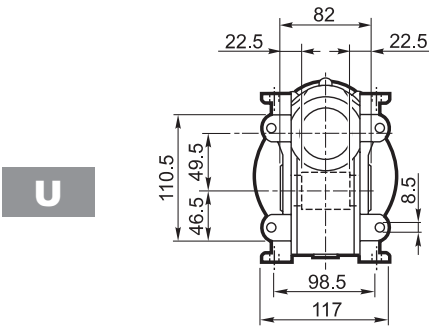
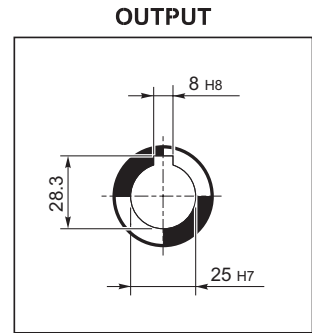
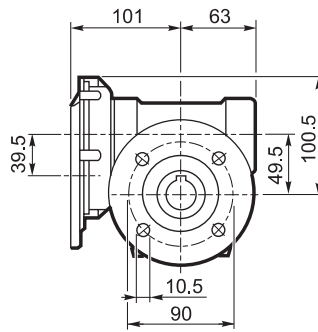
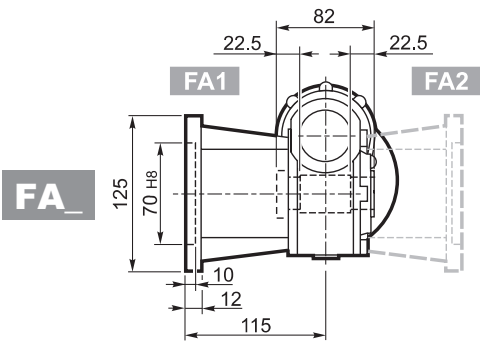
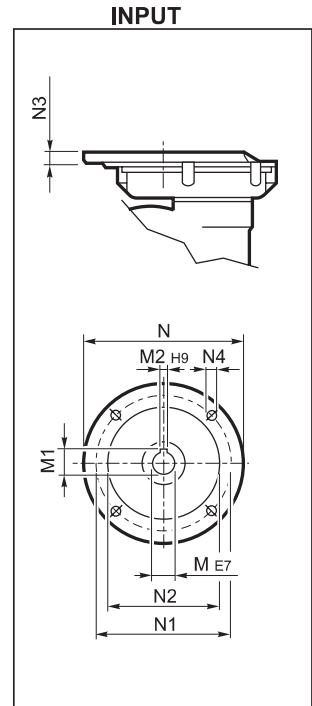
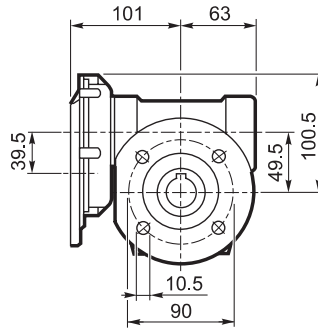
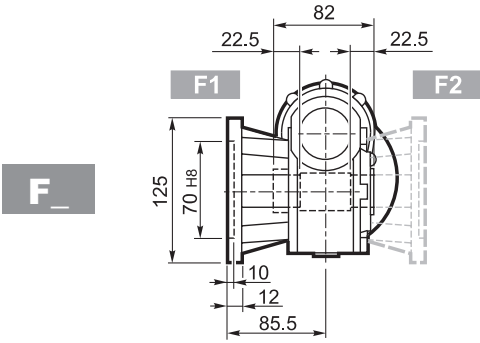

		M	M1	M2	N	N1	N2	N3	N4	
VFR 49	P63 B5	11	12.8	4	140	115	95	11	M8 x 19	5.0



VF/VF 30/49...P (IEC)

A

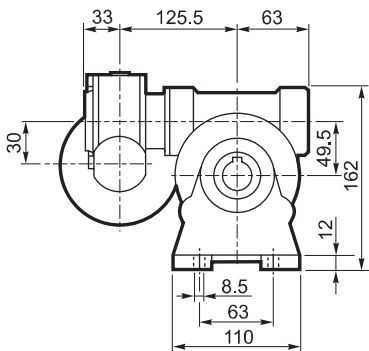

F

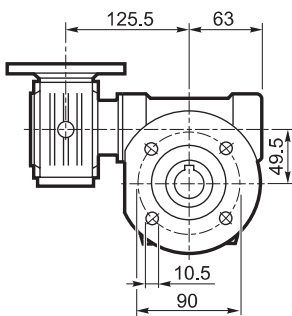

FA

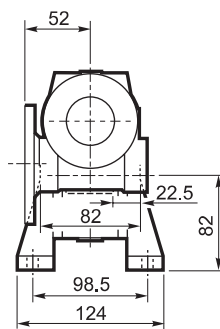
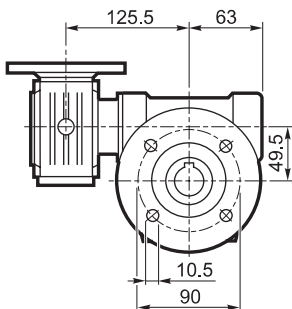

F2 **F1**

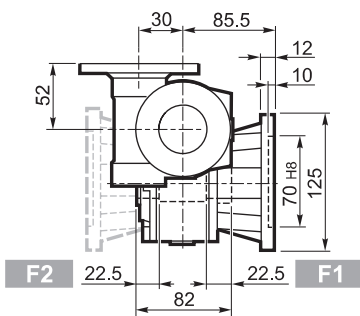

FA2 **FA1**

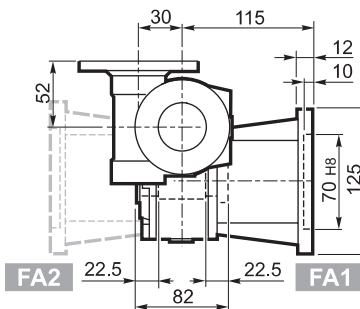

INPUT

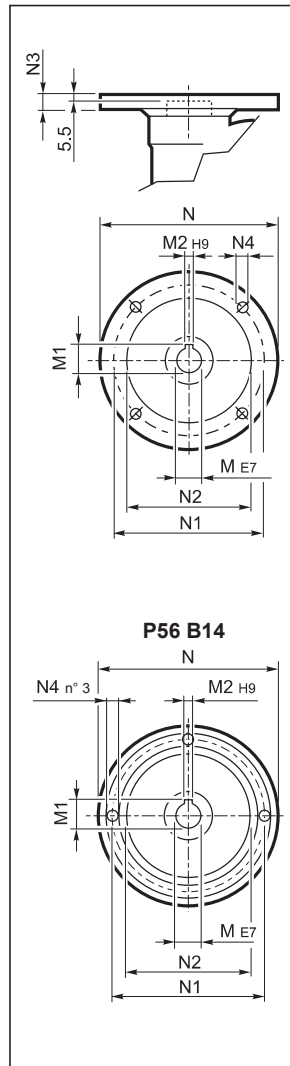

OUTPUT

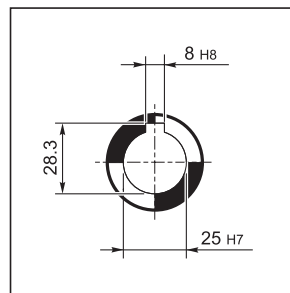



VF/VF 30/49...P (IEC)

P

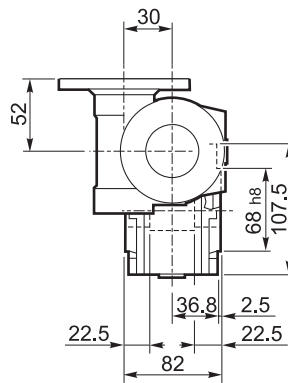
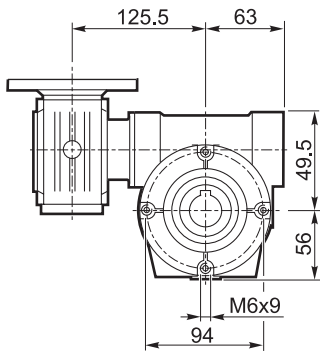

U

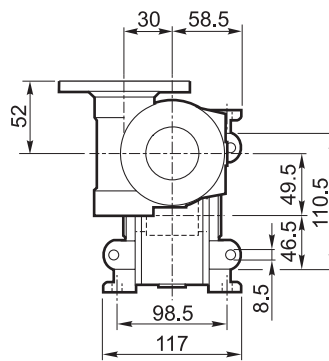
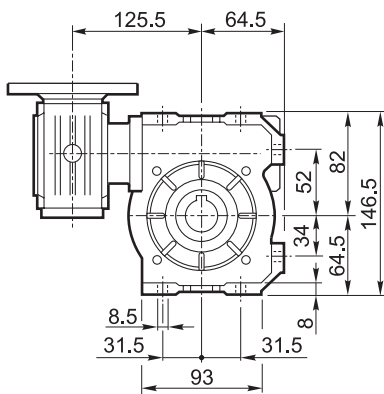

INPUT

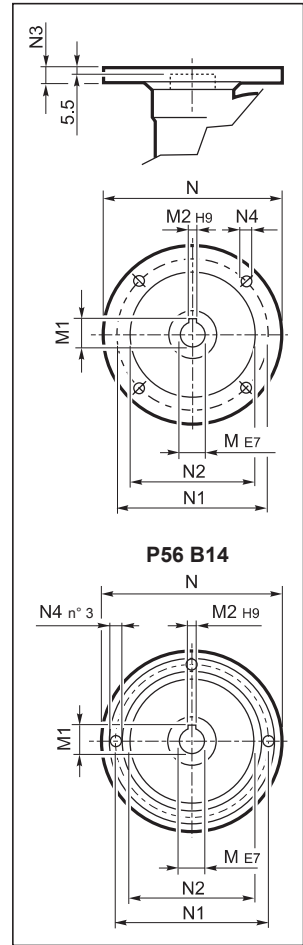

OUTPUT

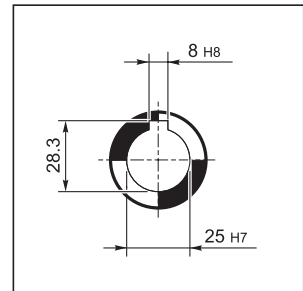

		M	M1	M2	N	N1	N2	N3	N4	
VF/VF 30/49	P56 B14	9	10.4	3	80	65	50	7	5.5	4.5
VF/VF 30/49	P63 B14	11	12.8	4	90	75	60	6	5.5	



W 63...M/ME

U

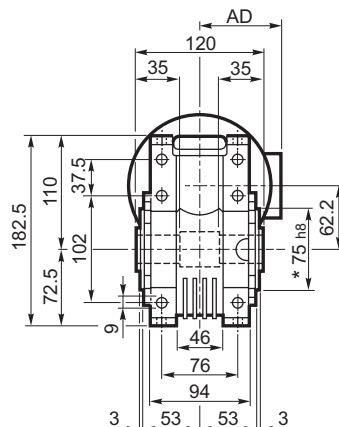
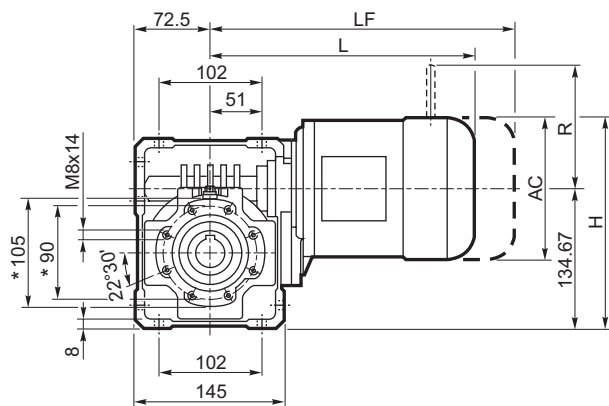

UF_

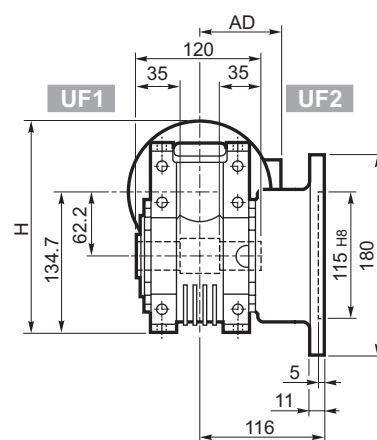
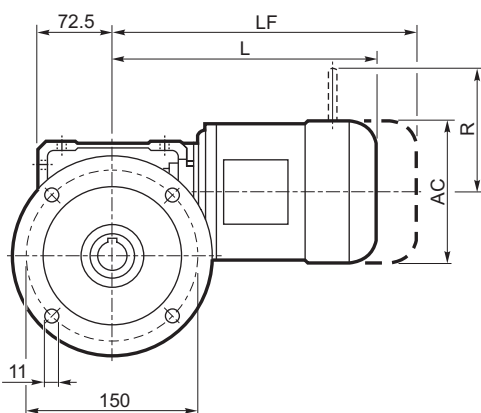

UFC_

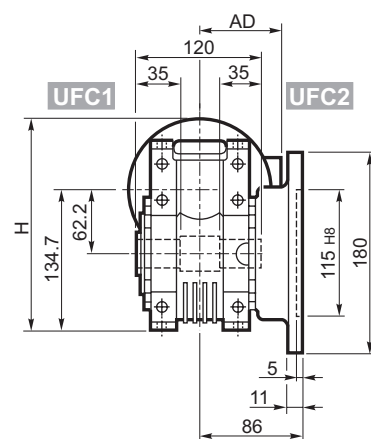
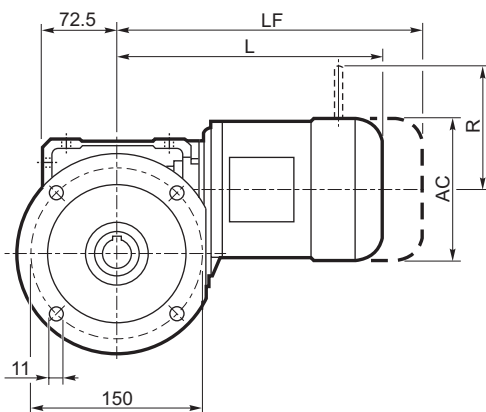

OUTPUT

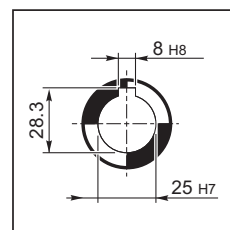

			M/ME				Kg	M...FD M...FA		M...FD		M...FA	
			AC	H	L	AD		LF	Kg	R	AD	R	AD
W 63	S1	M1	138	204	289	108	13	350	15	103	135	124	108
W 63	S2	M2S	156	213	317	119	17	393	20	129	146	134	119
W 63	S2	ME2S	156	213	317	119	17	—	—	—	—	—	—

* Auf beiden seiten



W 63...P (IEC)

U

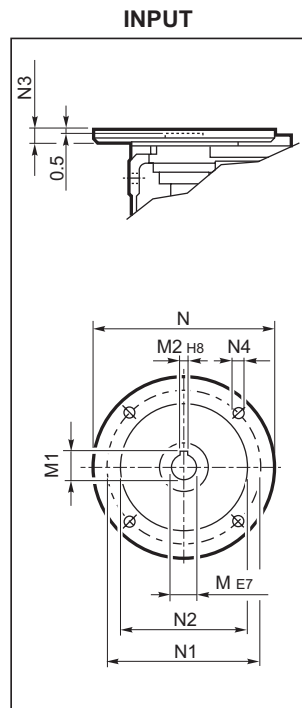
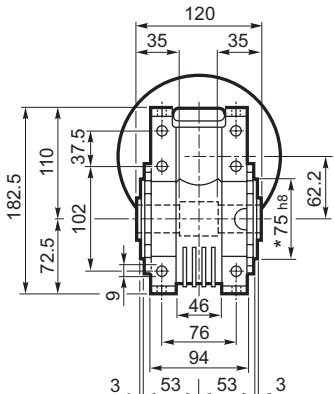
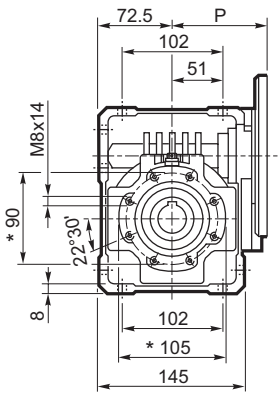

UF_

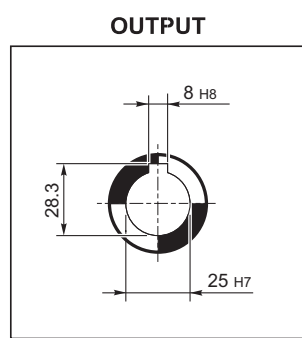
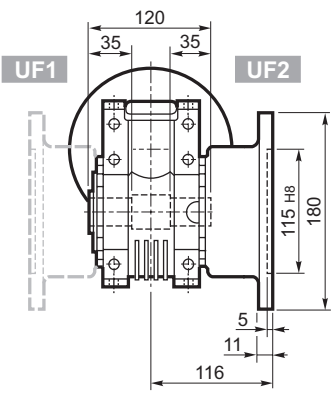
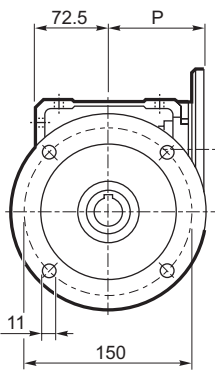

UFC_

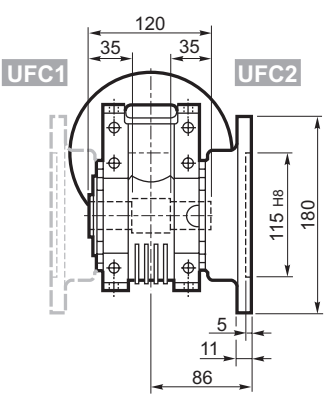
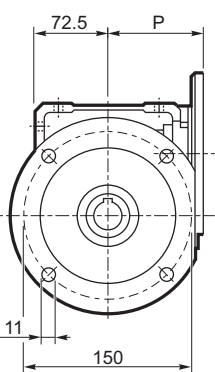

		M	M1	M2	N	N1	N2	N3	N4	P	Kg		
		W 63	P71 B5	14	16.3	5	160	130	110	11	9	95	6.3
		W 63	P80 B5	19	21.8	6	200	165	130	12	11.5	102	6.5
		W 63	P90 B5	24	27.3	8	200	165	130	12	11.5	102	6.4
		W 63	P71 B14	14	16.3	5	105	85	70	11	6.5	95	6.1
		W 63	P80 B14	19	21.8	6	120	100	80	11	6.5	102	6.3
		W 63	P90 B14	24	27.3	8	140	115	95	11	8.5	102	6.3



WR 63...P (IEC)

U

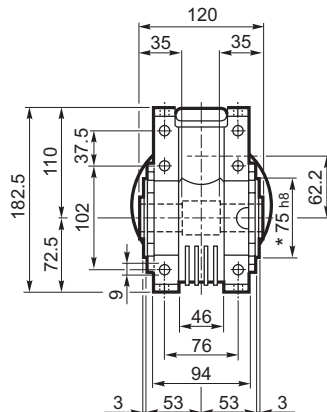
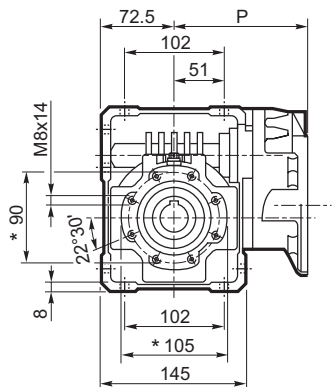

INPUT

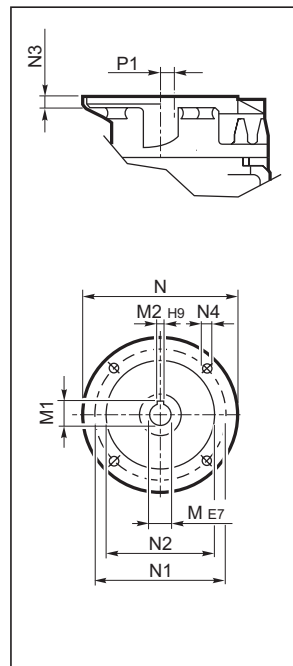

UF_

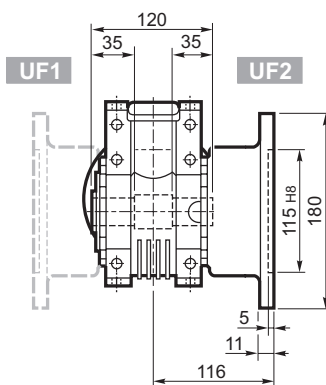
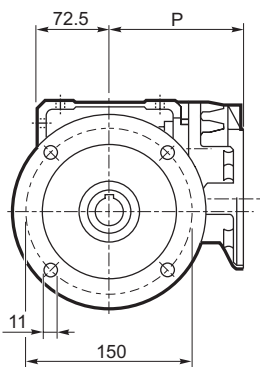

OUTPUT

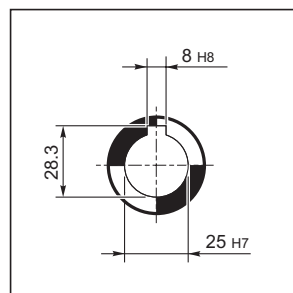

UFC_

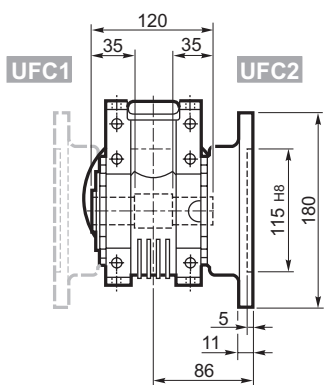
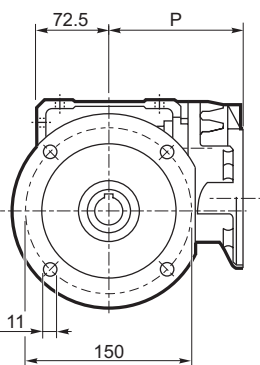

		M	M1	M2	N	N1	N2	N3	N4	P	P1	
WR 63	P63 B5	11	12.8	4	140	115	95	10	M8x10	133.5	11.42	7.1
WR 63	P71 B5	14	16.3	5	160	130	110	10	M8x10	133.5	11.42	

* Auf beiden seiten



VF/W 30/63...P (IEC)

U

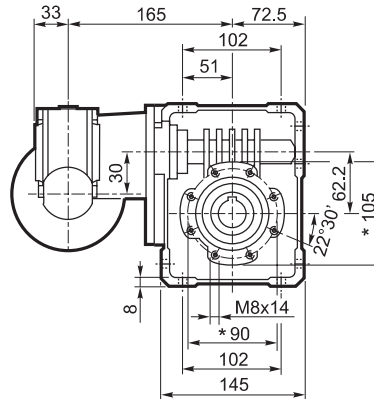
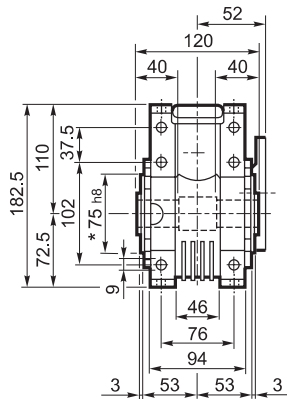

INPUT

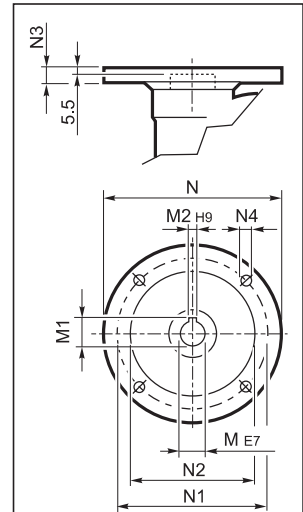

UF_

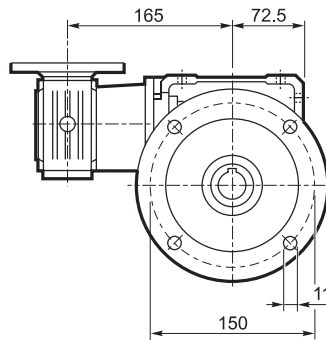
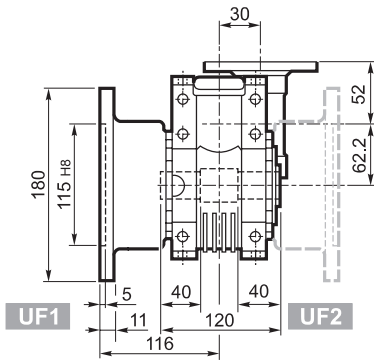

P56 B14

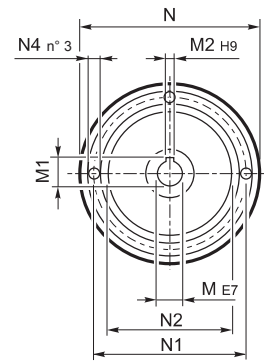

UFC_

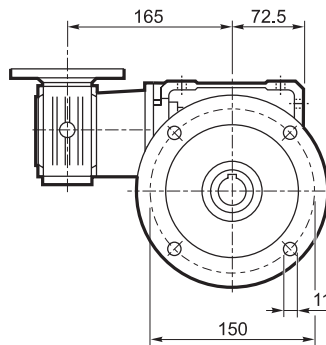
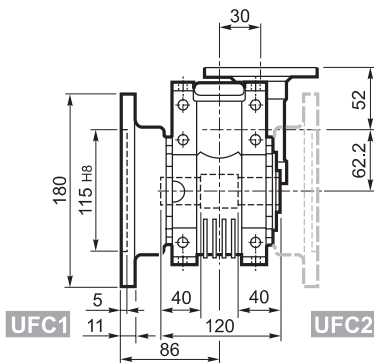

OUTPUT

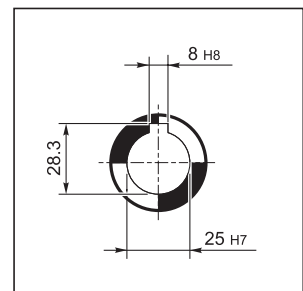

		M	M1	M2	N	N1	N2	N3	N4	
VF/W 30/63	P56 B5	9	10.4	3	120	100	80	7	7	8.0
VF/W 30/63	P63 B5	11	12.8	4	140	115	95	8	9.5	
VF/W 30/63	P56 B14	9	10.4	3	80	65	50	7	5.5	
VF/W 30/63	P63 B14	11	12.8	4	90	75	60	6	5.5	

* Auf beiden seiten



W 75...M/ME

U

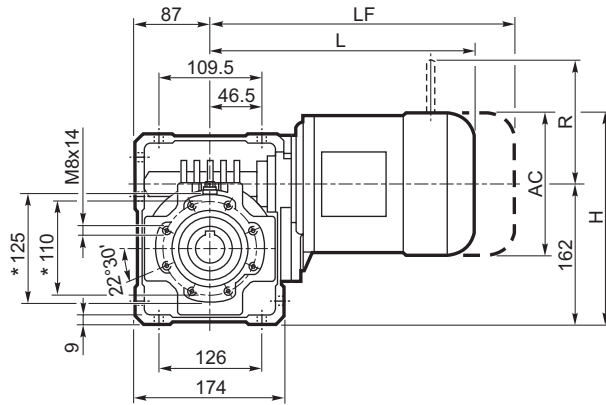

UF_

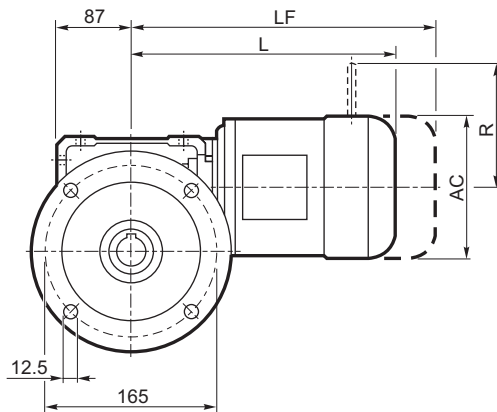

UFC_

UFCR_#

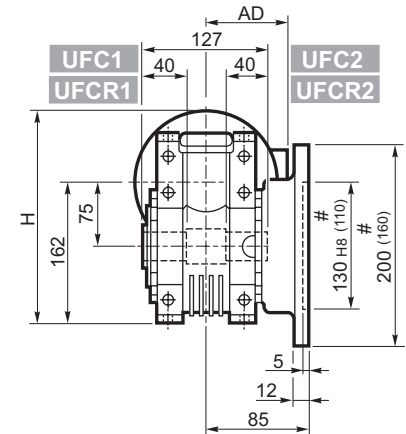
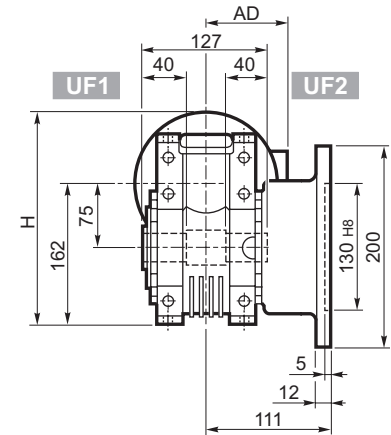
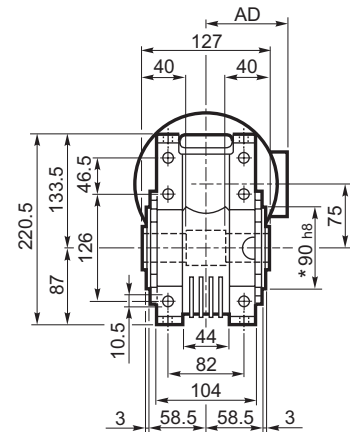
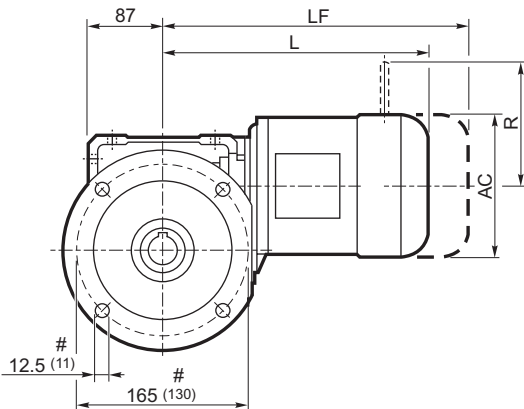

STANDARD OUTPUT

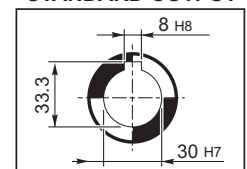

ON REQUEST OUTPUT

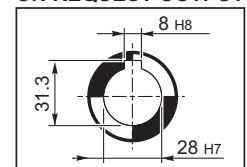

			M/ME				Kg	M...FD M...FA		Kg	M...FD		M...FA			
			AC	H	L	AD		LF	R		AD	R	AD			
			W 75	S1	M1	138	231	308	108	16.0	369	18.2	103	135	124	108
			W 75	S2	ME2S	153	240	333	119	18.5	—	—	—	—	—	—
			W 75	S3	ME3S	193	258.5	376	142	27.1	—	—	—	—	—	—
			W 75	S3	ME3L	193	258.5	408	142	32.6	—	—	—	—	—	—

* Auf beiden seiten

Verkürzte Flansch



W 75...P (IEC)

U

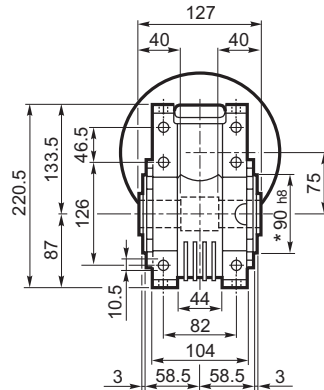
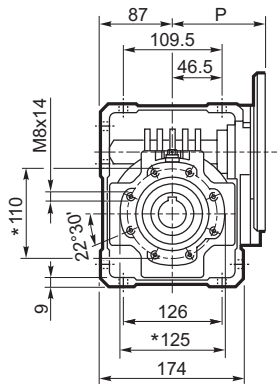

INPUT

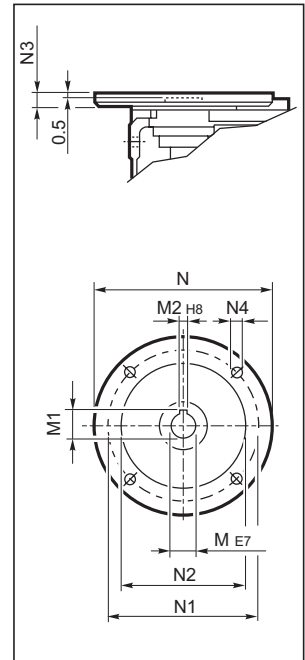

UF_

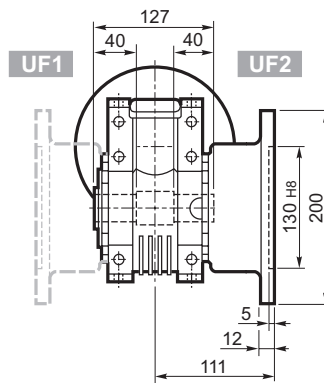
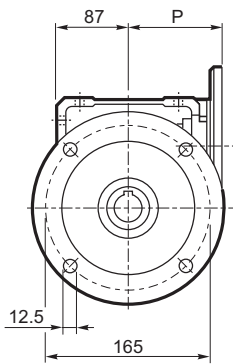

STANDARD OUTPUT

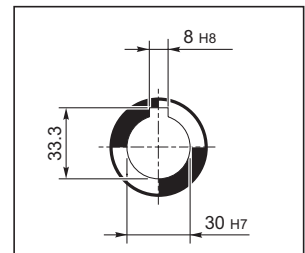



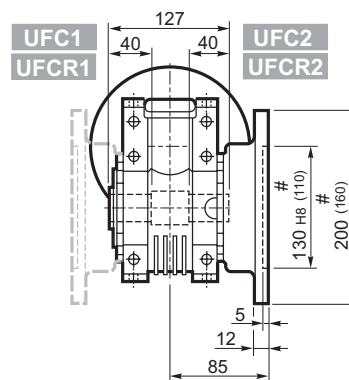
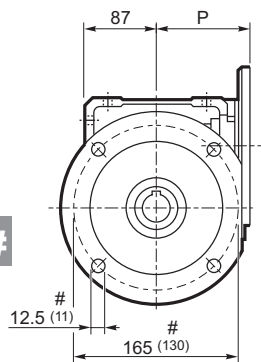

UFC_

UF CR #

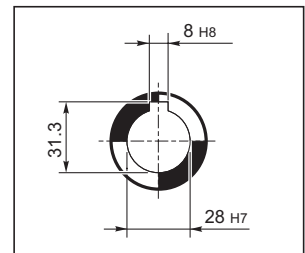

ON REQUEST OUTPUT



		M	M1	M2	N	N1	N2	N3	N4	P	 Kg
W 75	P71 B5	14	16.3	5	160	130	110	11	9	112	9.5
W 75	P80 B5	19	21.8	6	200	165	130	12	11.5	112	9.7
W 75	P90 B5	24	27.3	8	200	165	130	12	11.5	112	9.6
W 75	P100 B5	28	31.3	8	250	215	180	13	12.5	120	9.7
W 75	P112 B5	28	31.3	8	250	215	180	13	12.5	120	9.7
W 75	P80 B14	19	21.8	6	120	100	80	7.5	6.5	112	9.4
W 75	P90 B14	24	27.3	8	140	115	95	7.5	8.5	112	9.4
W 75	P100 B14	28	31.3	8	160	130	110	10	8.5	120	9.5
W 75	P112 B14	28	31.3	8	160	130	110	10	8.5	120	9.5

* Auf beiden Seiten

Verkürzte Flansch



WR 75...P (IEC)

U

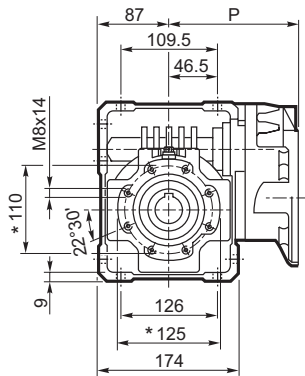

UF_

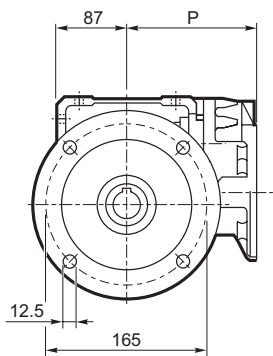

UFC_

UFCR_#

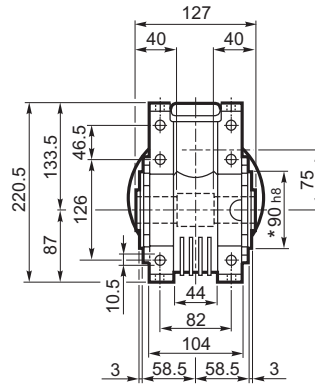
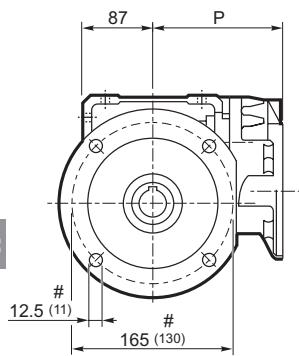

UF1

UF2

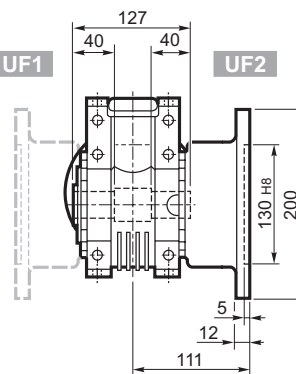

UFC1
UFCR1

UFC2
UFCR2

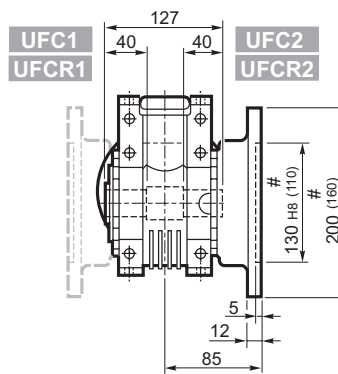

INPUT

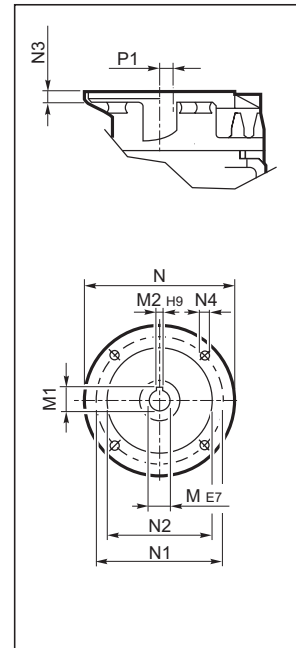

STANDARD OUTPUT

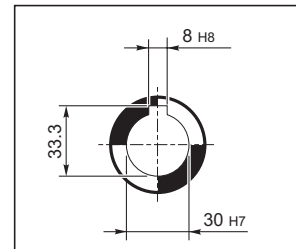

ON REQUEST OUTPUT

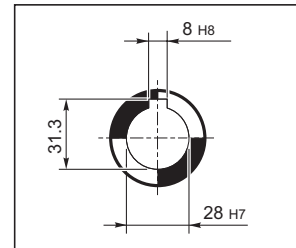

		M	M1	M2	N	N1	N2	N3	N4	P	P1	
WR 75	P63 B5	11	12.8	4	140	115	95	10	M8x10	152	23.53	10.6
WR 75	P71 B5	14	16.3	5	160	130	110	10	M8x10	152	23.53	10.7
WR 75	P80 B5	19	21.8	6	200	165	130	12	M10x13	163.5	11	11.5
WR 75	P90 B5	24	27.3	8	200	165	130	12	M10x13	163.5	11	11.6

* Auf beiden seiten

Verkürzte Flansch



VF/W 44/75...P (IEC)

U

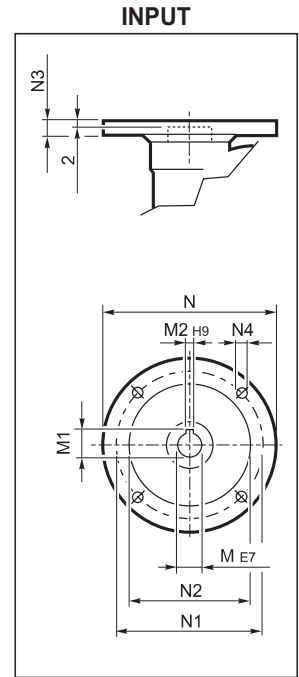
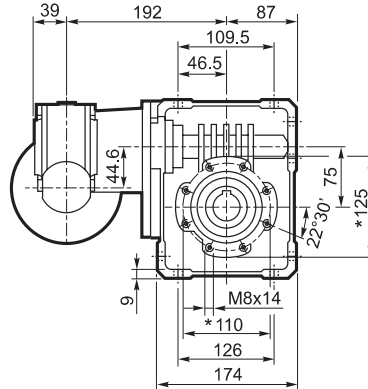
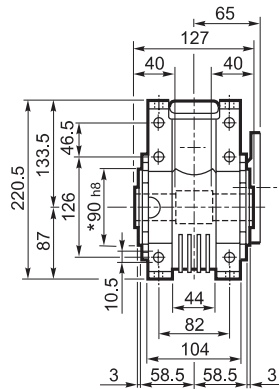

UF_

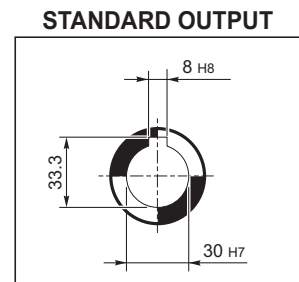
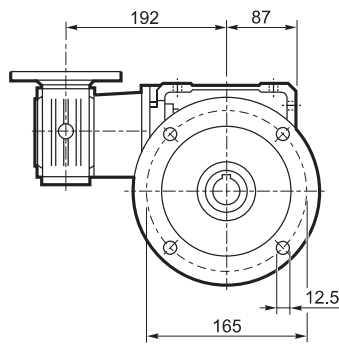
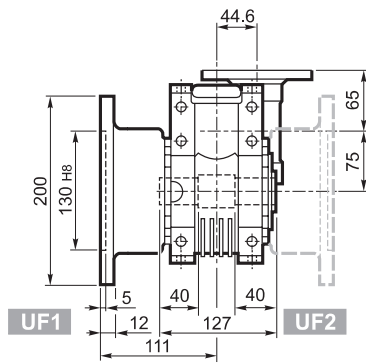

UFC_

UFCR_#

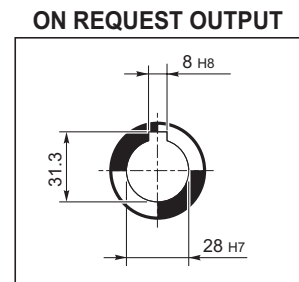
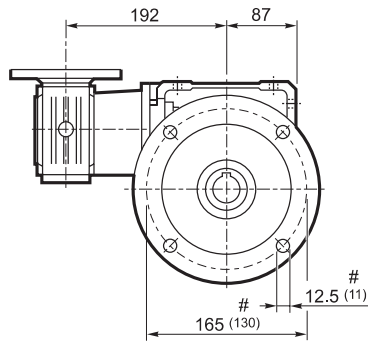
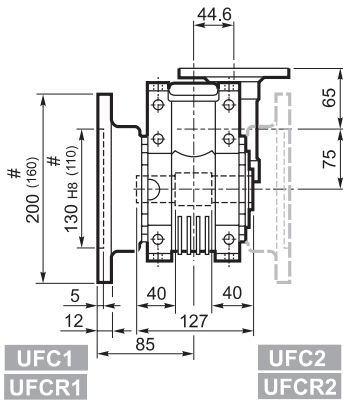

		M	M1	M2	N	N1	N2	N3	N4	kg
VF/W 44/75	P63 B5	11	12.8	4	140	115	95	10	9.5	12.5
VF/W 44/75	P71 B5	14	16.3	5	160	130	110	10	9.5	
VF/W 44/75	P63 B14	11	12.8	4	90	75	60	8	5.5	
VF/W 44/75	P71 B14	14	16.3	5	105	85	70	10	7	

* Auf beiden seiten

Verkürzte Flansch



W 86...M/ME

U

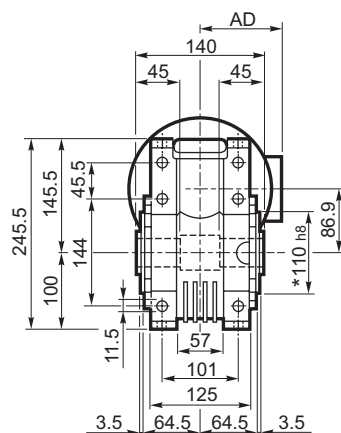
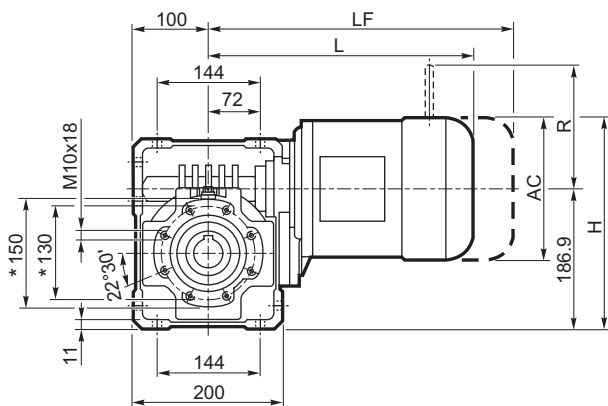

UF_

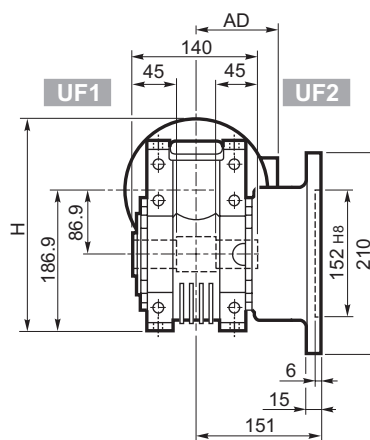
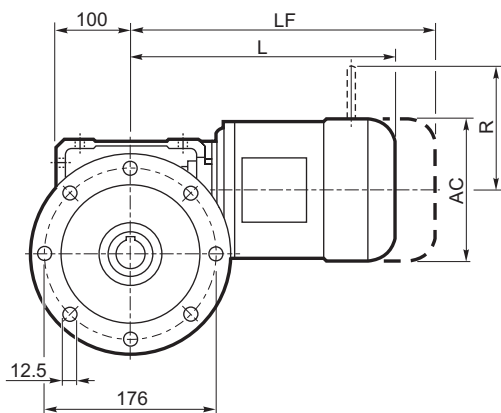

UFC_

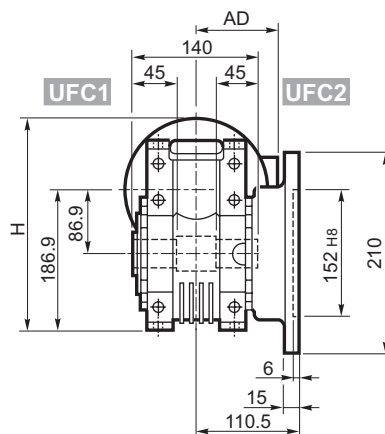
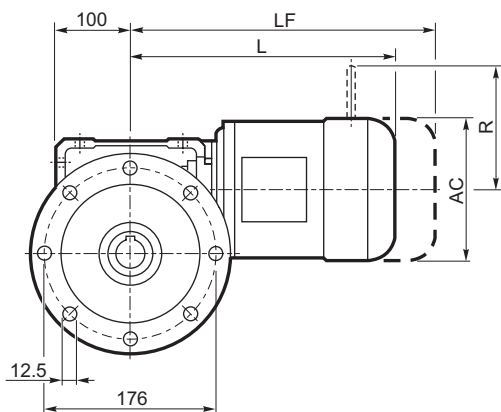

			M/ME				Kg	M...FD M...FA		M...FD		M...FA				
			AC	H	L	AD		LF	Kg	R	AD	R	AD			
			W 86	S1	M1	138	256	324	108	20.1	385	22.3	103	135	124	108
W 86	S2	M2S	156	265	349	119	22.6	425	25.7	129	146	134	119			
W 86	S2	ME2S	156	265	349	119	22.6	—	—	—	—	—	—			
W 86	S3	ME3S	193	283.5	392	142	31.2	—	—	—	—	—	—			
W 86	S3	ME3L	193	283.5	424	142	36.7	—	—	—	—	—	—			

OUTPUT

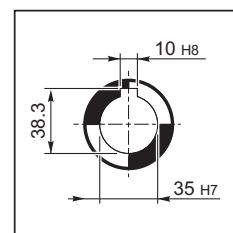

* Auf beiden seiten



W 86...P (IEC)

U

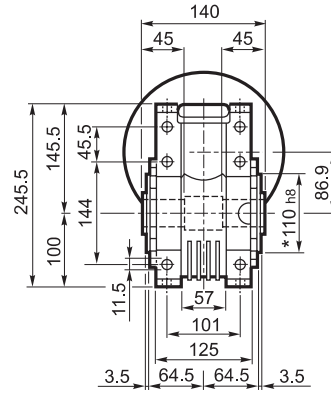
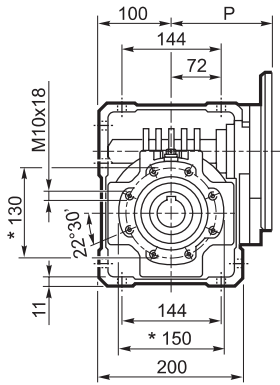

INPUT

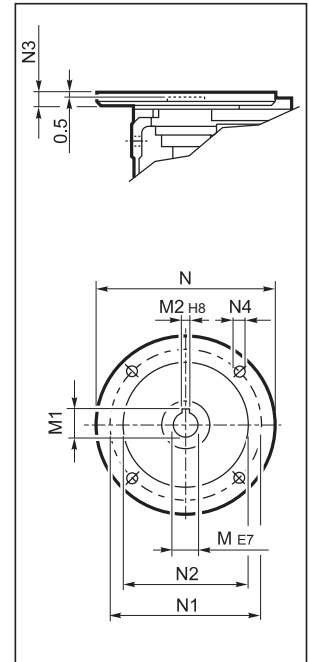

UF

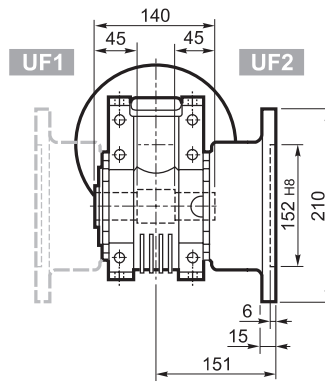
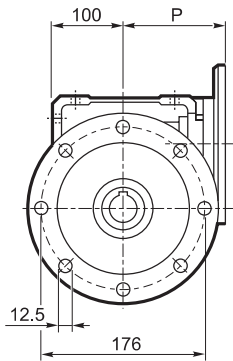

OUTPUT

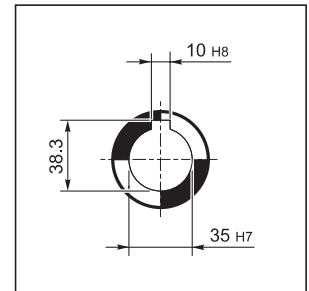

UFC

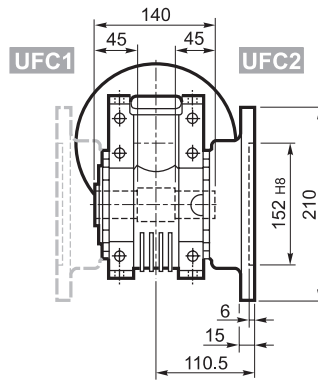
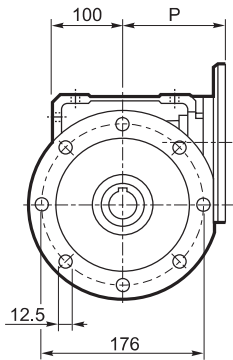

		M	M1	M2	N	N1	N2	N3	N4	P	
W 86	P71 B5	14	16.3	5	160	130	110	11	9	128	13.6
W 86	P80 B5	19	21.8	6	200	165	130	12	11.5	128	13.8
W 86	P90 B5	24	27.3	8	200	165	130	12	11.5	128	13.7
W 86	P100 B5	28	31.3	8	250	215	180	13	12.5	136	13.8
W 86	P112 B5	28	31.3	8	250	215	180	13	12.5	136	13.8
W 86	P80 B14	19	21.8	6	120	100	80	7.5	6.5	128	13.5
W 86	P90 B14	24	27.3	8	140	115	95	7.5	8.5	128	13.5
W 86	P100 B14	28	31.3	8	160	130	110	10	8.5	136	13.6
W 86	P112 B14	28	31.3	8	160	130	110	10	8.5	136	13.6

* Auf beiden Seiten



WR 86...P (IEC)

U

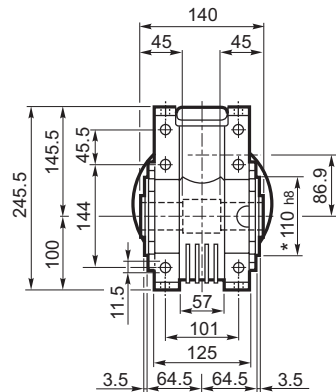
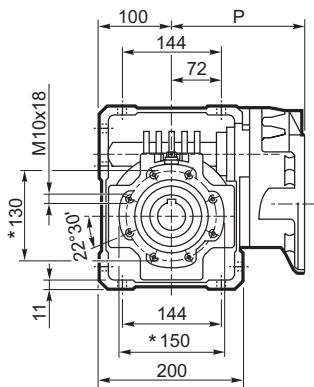

INPUT

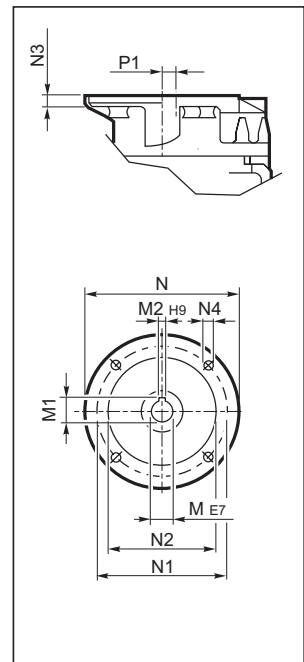

UF

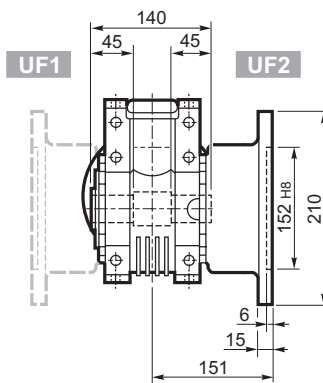
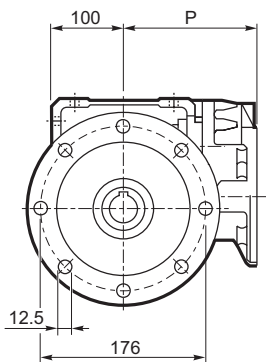

OUTPUT

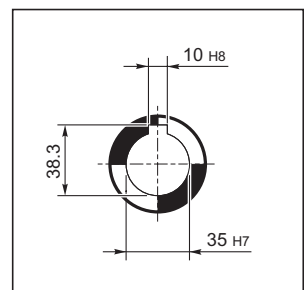

UFC

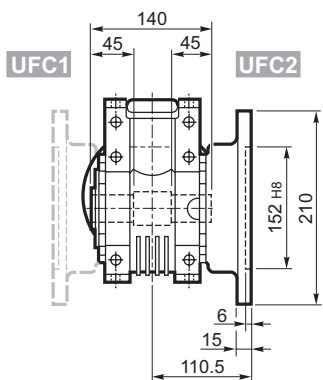
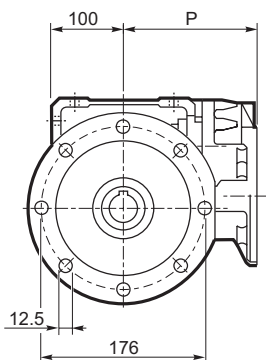

		M	M1	M2	N	N1	N2	N3	N4	P	P1	
WR 86	P63 B5	11	12.8	4	140	115	95	10	M8x10	168	35.4	14.3
WR 86	P71 B5	14	16.3	5	160	130	110	10	M8x10	168	35.4	14.4
WR 86	P80 B5	19	21.8	6	200	165	130	12	M10x13	179.5	22.9	15.2
WR 86	P90 B5	24	27.3	8	200	165	130	12	M10x13	179.5	22.9	15.3

* Auf beiden seiten



VF/W 44/86... P (IEC)

U

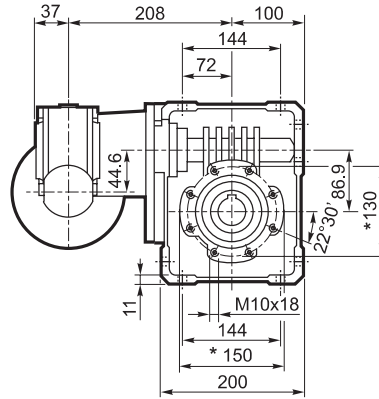
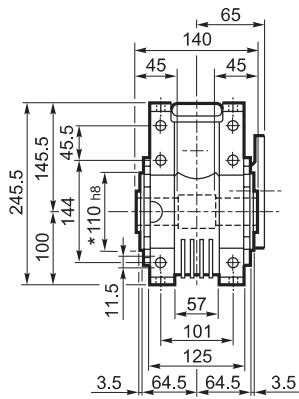

INPUT

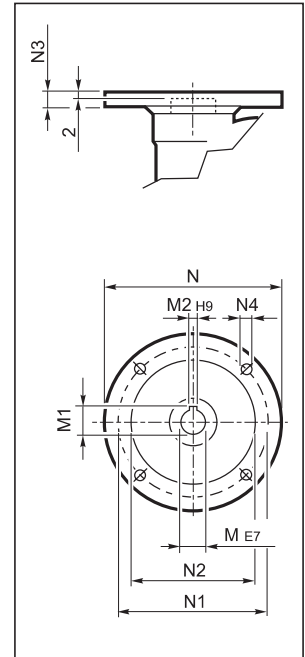

UF_

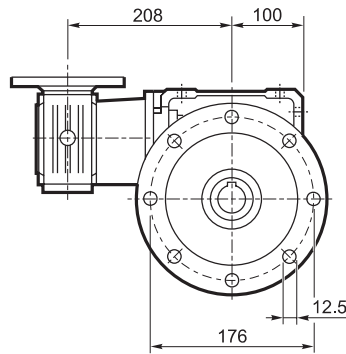
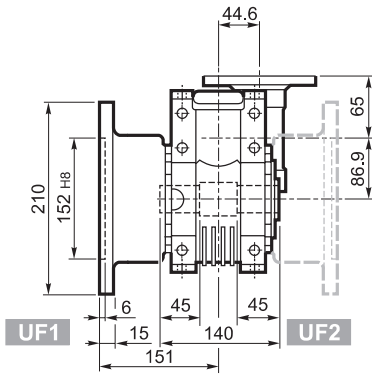

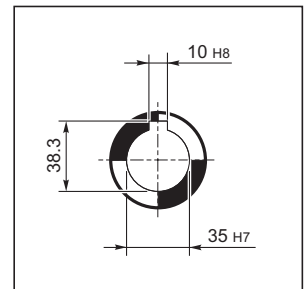

OUTPUT

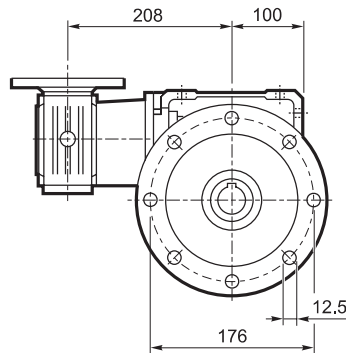
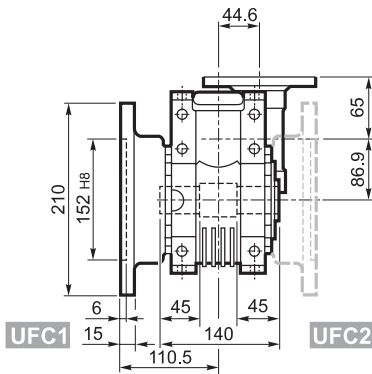

UFC_



		M	M1	M2	N	N1	N2	N3	N4	
VF/W 44/86	P63 B5	11	12.8	4	140	115	95	10	9.5	16.6
VF/W 44/86	P71 B5	14	16.3	5	160	130	110	10	9.5	
VF/W 44/86	P63 B14	11	12.8	4	90	75	60	8	5.5	
VF/W 44/86	P71 B14	14	16.3	5	105	85	70	10	7	

* Auf beiden seiten



W 110...M/ME

U

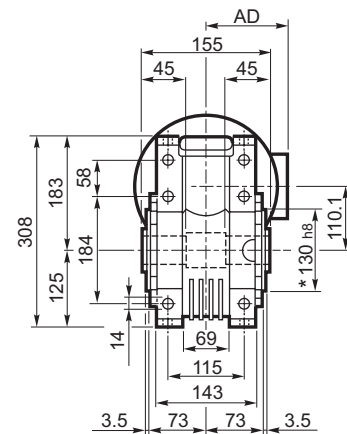
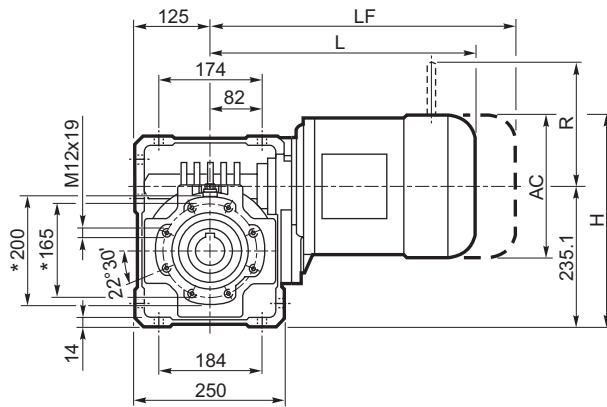

UF

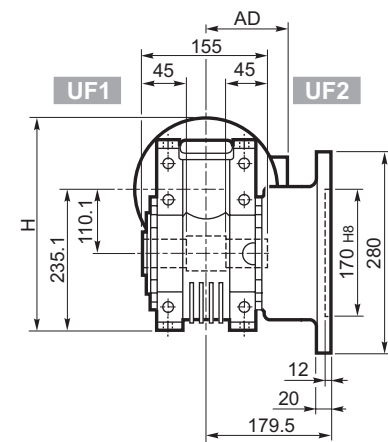
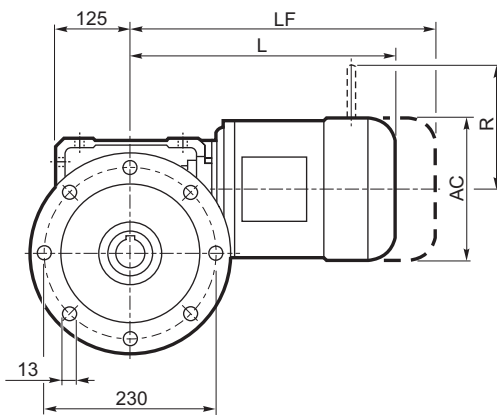

UFC

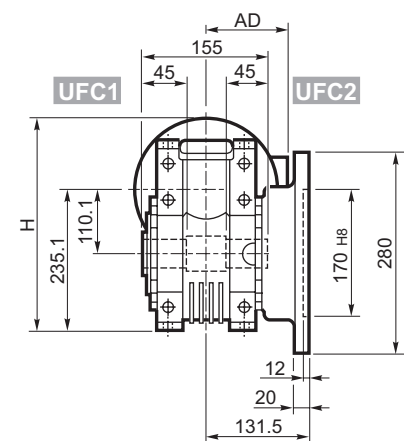
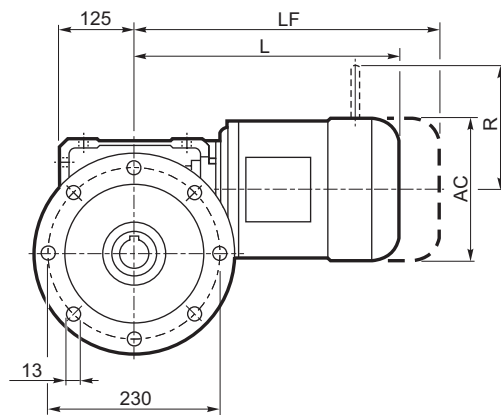

			M/ME				Kg	M...FD M...FA		Kg	M...FD		M...FA			
			AC	H	L	AD		LF	R		AD	R	AD			
			W 110	S2	M2S	156	313	364	119	38	440	41	129	146	134	119
W 110	S2	ME2S	156	313	364	119	38	—	—	—	—	—	—	—	—	
W 110	S3	ME3S	193	332	407	142	47.5	—	—	—	—	—	—	—	—	
W 110	S3	ME3L	193	332	439	142	53	—	—	—	—	—	—	—	—	

OUTPUT

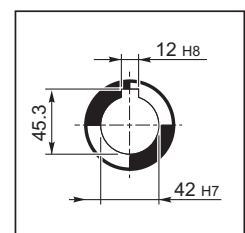

* Auf beiden Seiten



W 110...P (IEC)

U

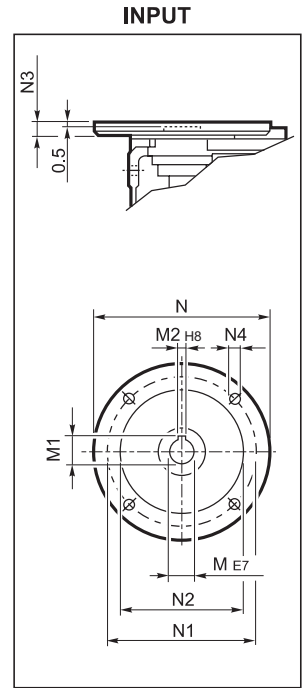
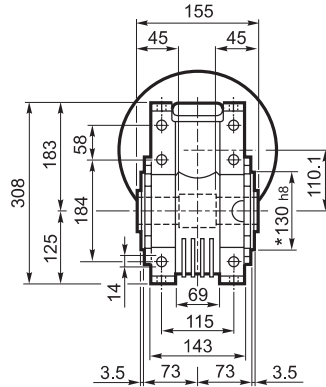
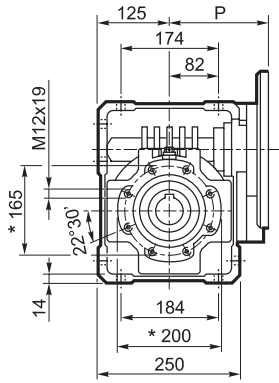

UF_

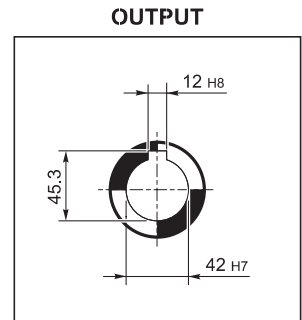
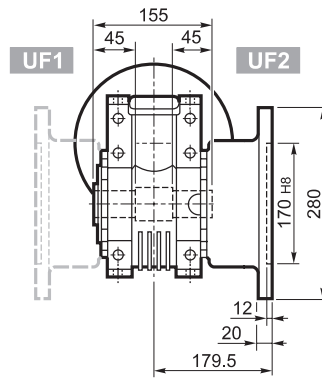
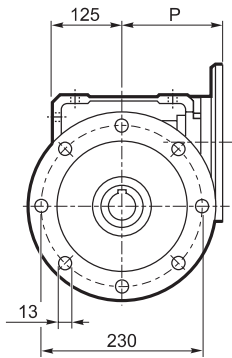

UFC_

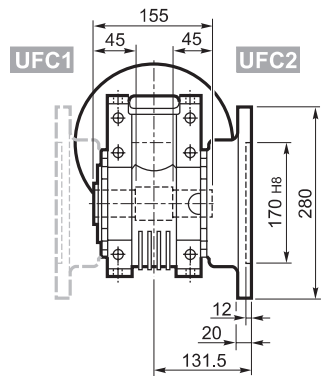
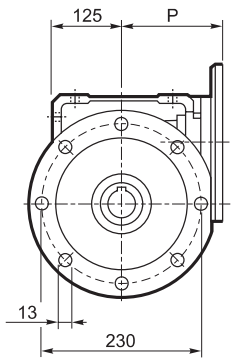

		M	M1	M2	N	N1	N2	N3	N4	P	
W 110	P80 B5	19	21.8	6	200	165	130	—	M10x12	143	28
W 110	P90 B5	24	27.3	8	200	165	130	—	M10x12	143	28
W 110	P100 B5	28	31.3	8	250	215	180	13	13	151	29
W 110	P112 B5	28	31.3	8	250	215	180	13	13	151	29
W 110	P132 B5	38	41.3	10	300	265	230	16	14	226	31
W 110	P80 B14	19	21.8	6	120	100	80	7.5	7	143	27.5
W 110	P90 B14	24	27.3	8	140	115	95	6.5	9	143	27.5
W 110	P100 B14	28	31.3	8	160	130	110	13	9	151	27
W 110	P112 B14	28	31.3	8	160	130	110	13	9	151	27

* Auf beiden seiten



WR 110...P (IEC)

U

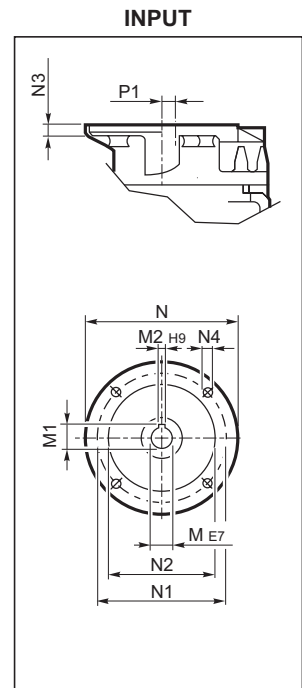
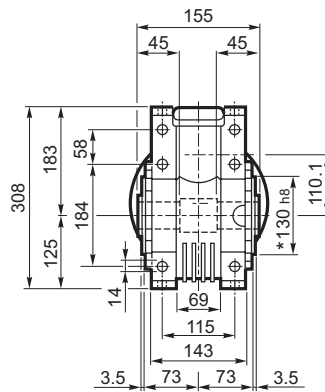
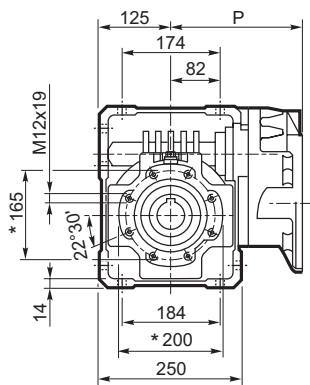

UF_

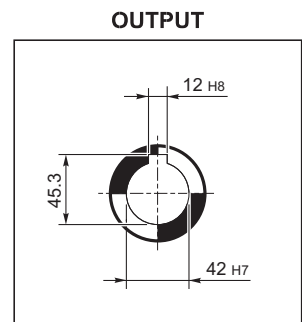
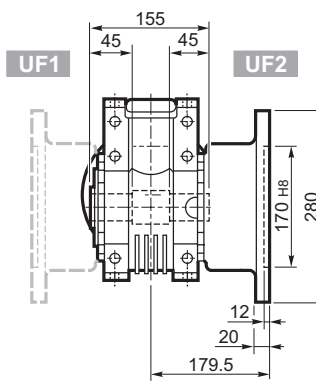
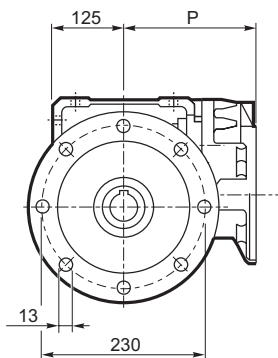

UFC_

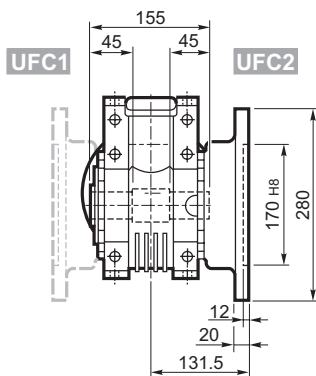
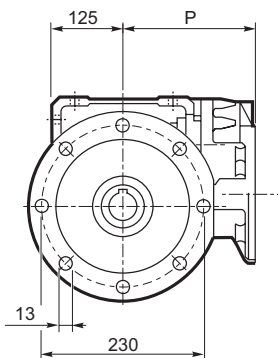

		M	M1	M2	N	N1	N2	N3	N4	P	P1	
WR 110	P71 B5	14	16.3	5	160	130	110	10	M8x14	185	58.6	30.5
WR 110	P80 B5	19	21.8	6	200	165	130	14	M10x15	204	21.1	31
WR 110	P90 B5	24	27.3	8	200	165	130	14	M10x15	204	21.1	31
WR 110	P100 B5	28	31.3	8	250	215	180	14	M12x13	213	21.1	32
WR 110	P112 B5	28	31.3	8	250	215	180	14	M12x13	213	21.1	32

* Auf beiden seiten

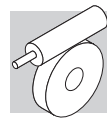

VF/W 49/110...P (IEC)

U

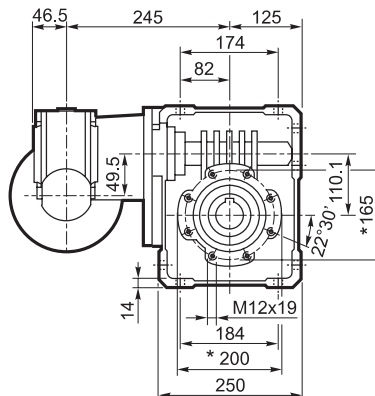
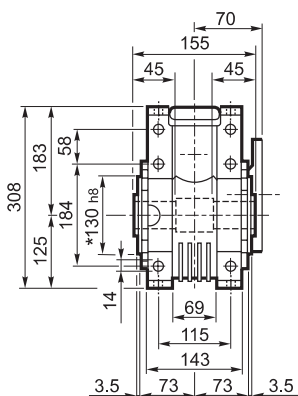

INPUT

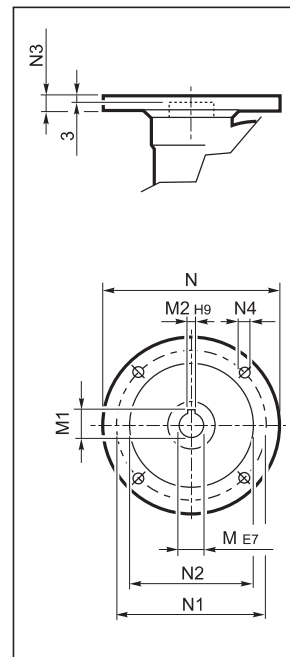

UF

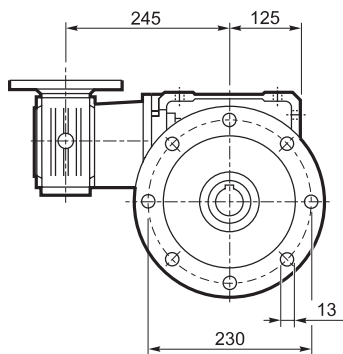
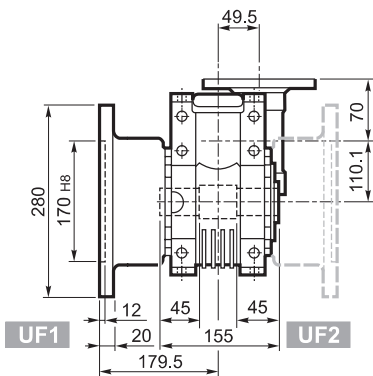

OUTPUT

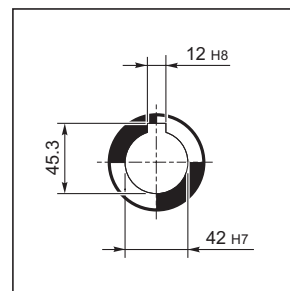

UFC

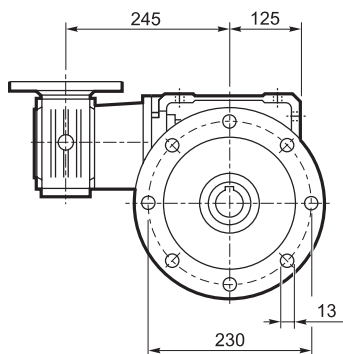
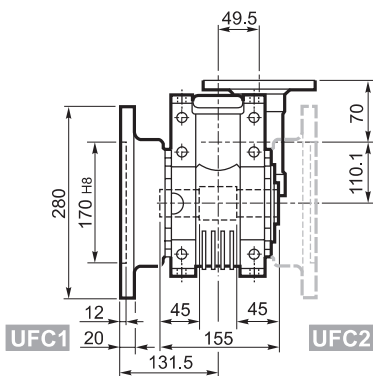

		M	M1	M2	N	N1	N2	N3	N4	Kg
		11	12.8	4	140	115	95	10.5	9.5	33
VF/W 49/110	P63 B5	14	16.3	5	160	130	110	10.5	9.5	
VF/W 49/110	P71 B5	19	21.8	6	200	165	130	10	11.5	
VF/W 49/110	P63 B14	11	12.8	4	90	75	60	7	6	
VF/W 49/110	P71 B14	14	16.3	5	105	85	70	10.5	6.5	
VF/W 49/110	P80 B14	19	21.8	6	120	100	80	10	7	

* Auf beiden seiten



VF 130...P (IEC)

A

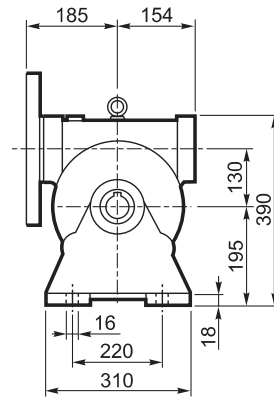
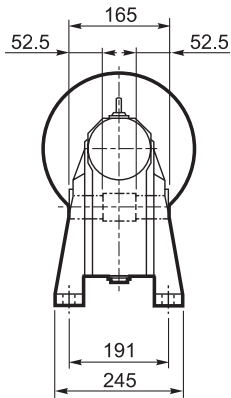

N

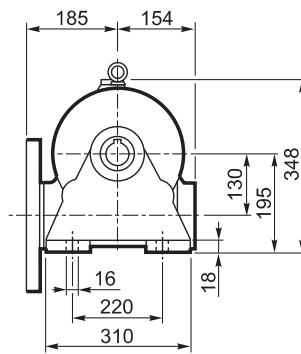
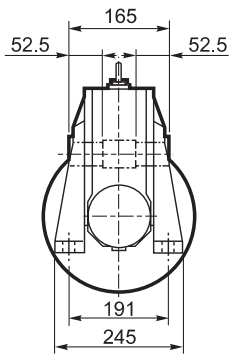

V

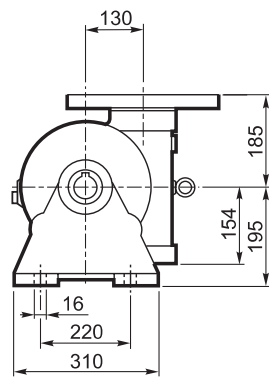
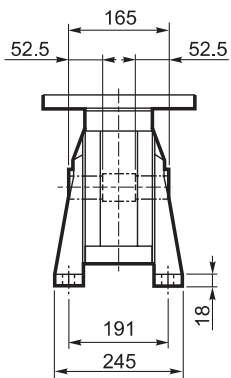

INPUT

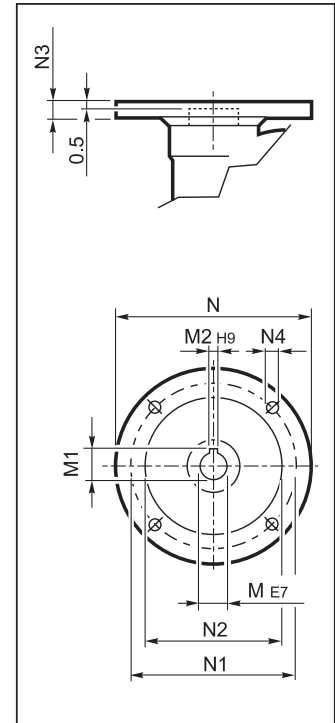

OUTPUT

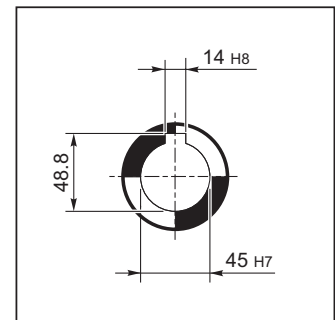



VF 130...P (IEC)

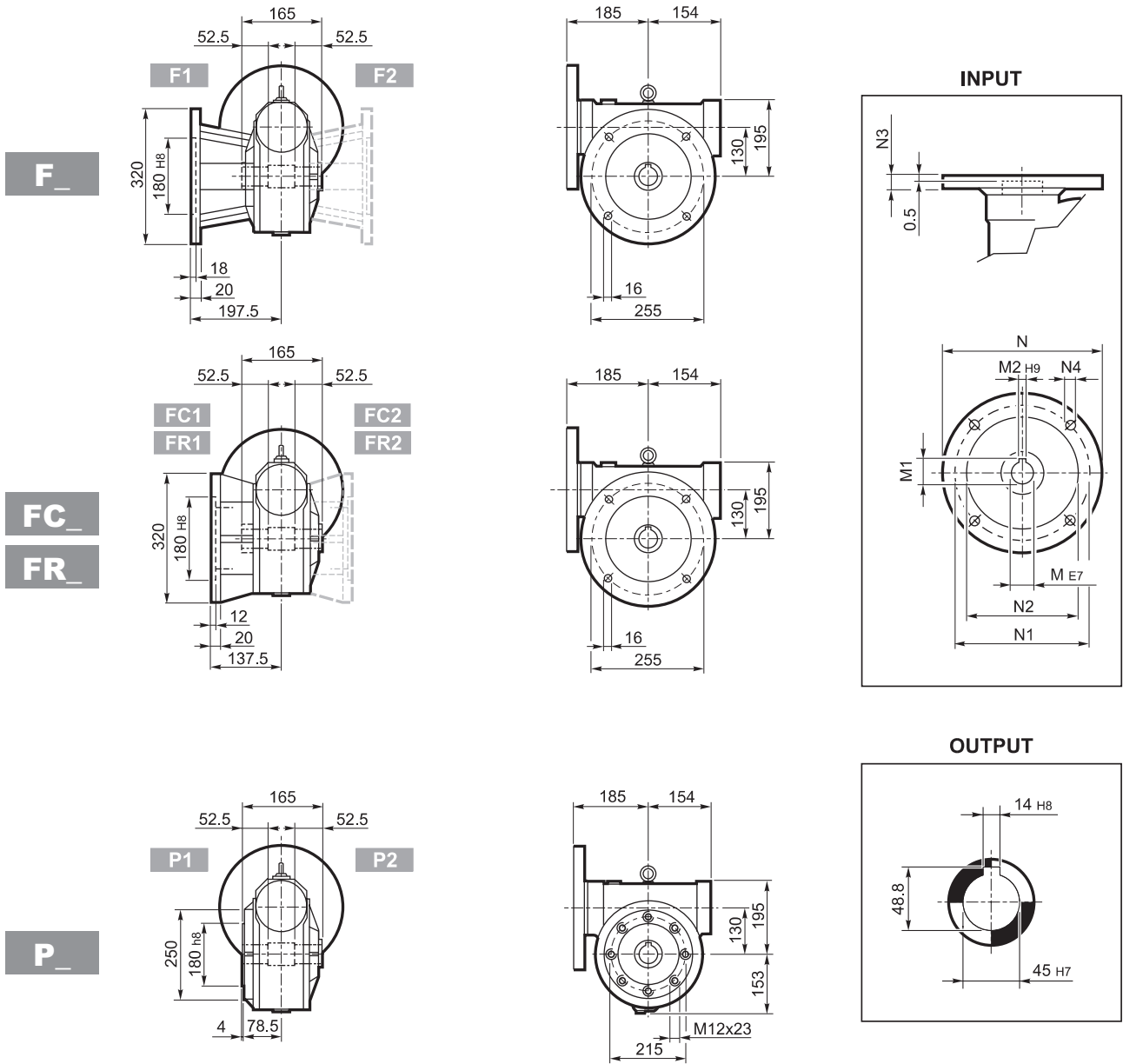

		M	M1	M2	N	N1	N2	N3	N4	
VF130	P90 B5	24	27.3	8	200	165	130	17	11	49
VF130	P100 B5	28	31.3	8	250	215	180	17	13	
VF130	P112 B5	28	31.3	8	250	215	180	17	13	
VF130	P132 B5	38	40.1#	10	300	265	230	17	13	

Verkleinertes Paßfeder



VFR 130...P (IEC)

A

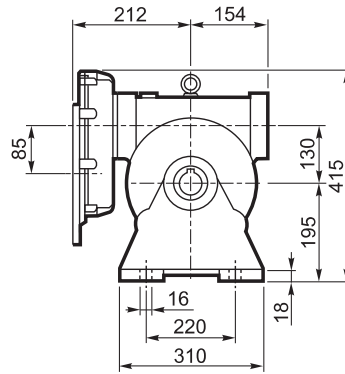
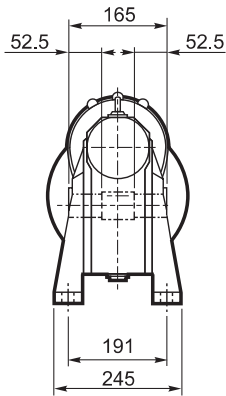

INPUT

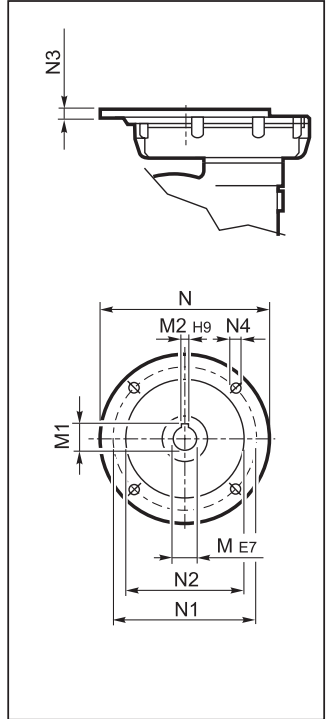

N

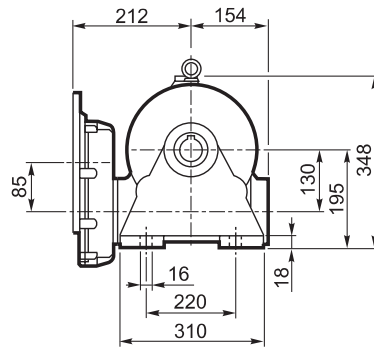
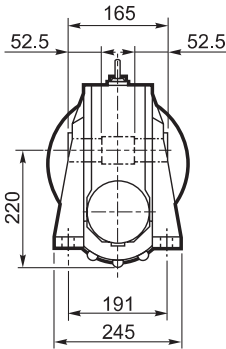

OUTPUT

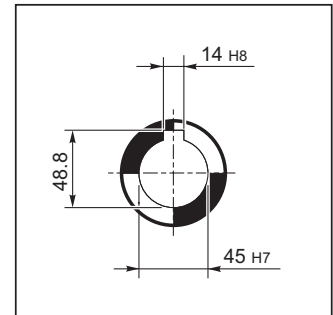



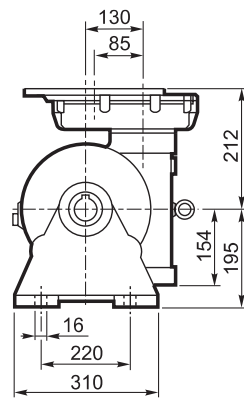
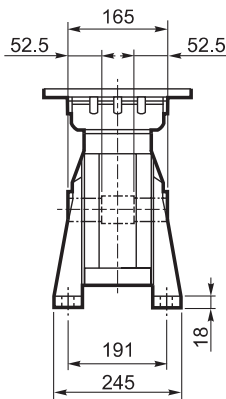

V



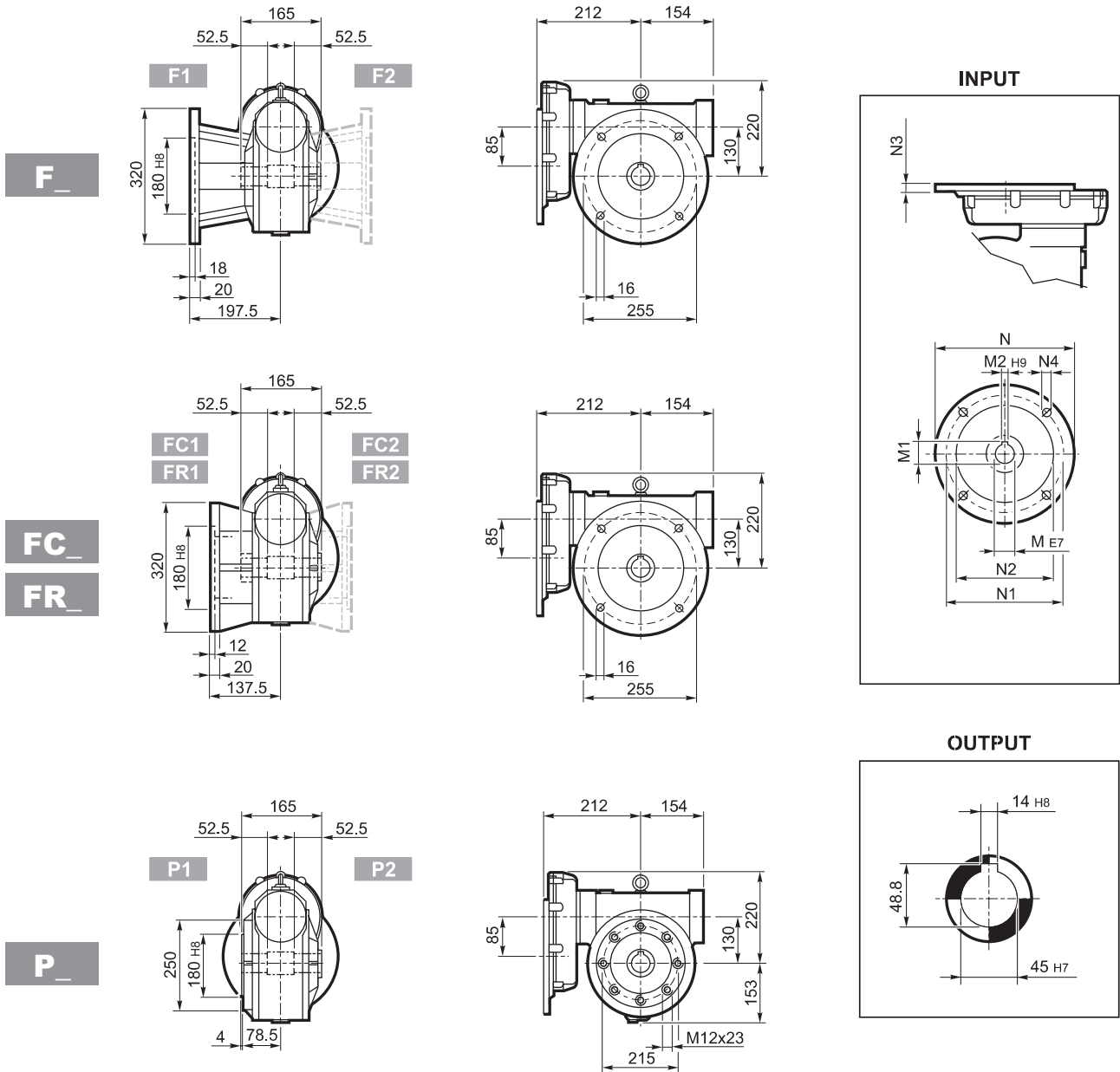

VFR 130...P (IEC)



		M	M1	M2	N	N1	N2	N3	N4	
VFR 130	P80 B5	19 K6	21.8	6	200	165	130	12	M10x25	57
VFR 130	P90 B5	24 K6	27.3	8	200	165	130	12	M10x25	
VRF 130	P100 B5	28 J6	29.1#	8	250	215	180	13	M12x35	
VRF 130	P112 B5	28 J6	29.1#	8	250	215	180	13	M12x35	

Verkleinertes Paßfeder



W/VF 63/130...M/ME

A

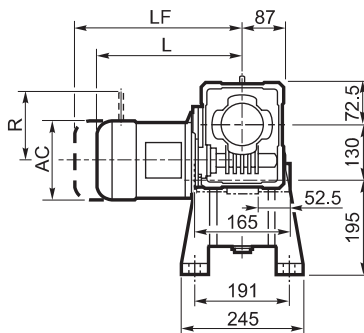
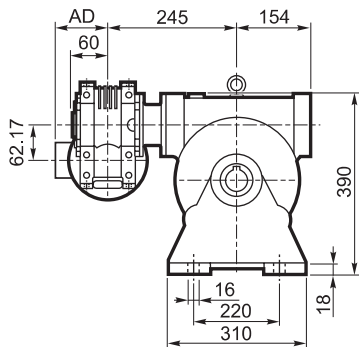

F_

FC_

FR_

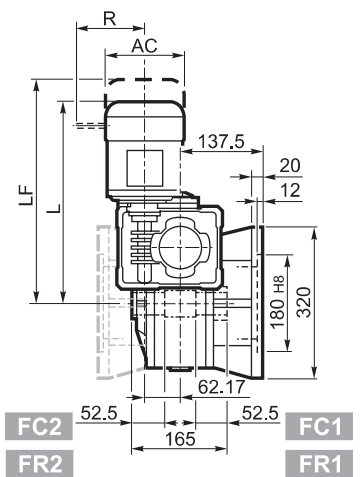
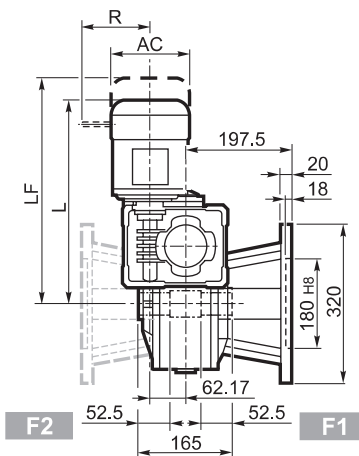
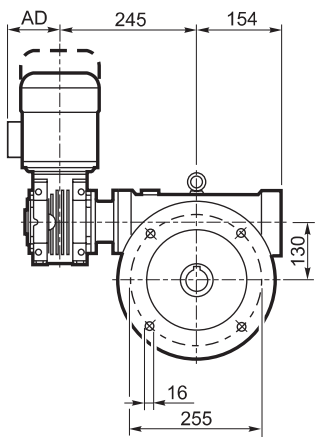

P_

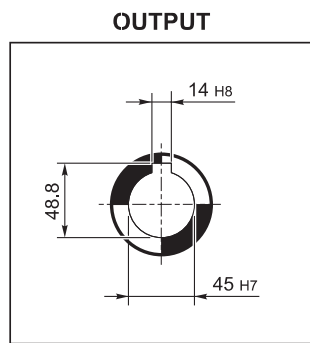
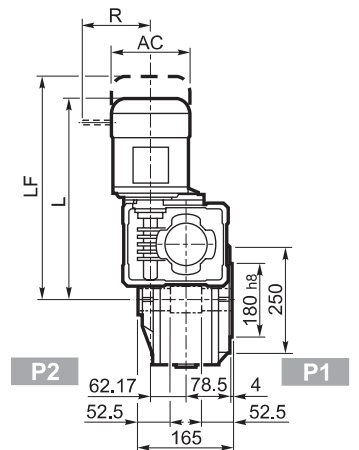
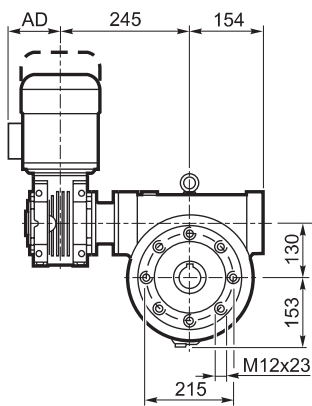

			M/ME				M...FD M...FA		M...FD		M...FA	
			AC	L	AD	Kg	LF	Kg	R	AD	R	AD
			138	419	108	63	480	65	103	135	124	108
W/VF 63/130	S1	M1	156	447	119	68	—	—	—	—	—	—
W/VF 63/130	S2	ME2S										



W/VF 63/130...P (IEC)

A

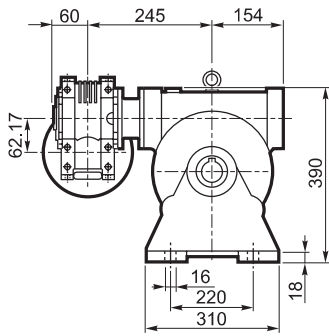

F_

FC_

FR_

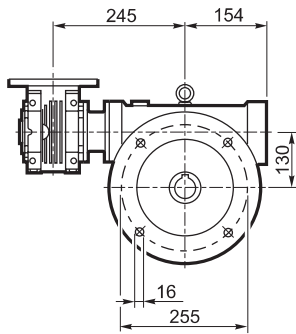

F2

F1

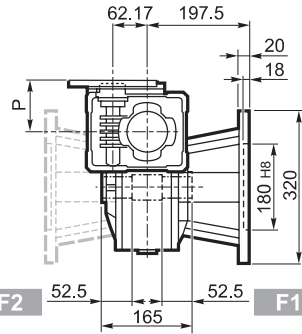

FC2

FC1

FR2

FR1

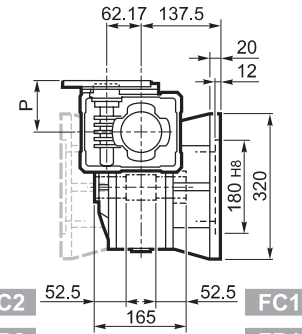

P_

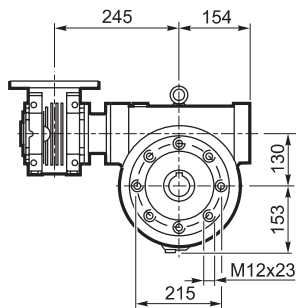

P2

P1

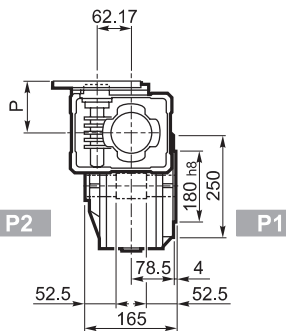

OUTPUT

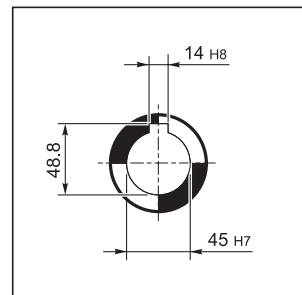

INPUT

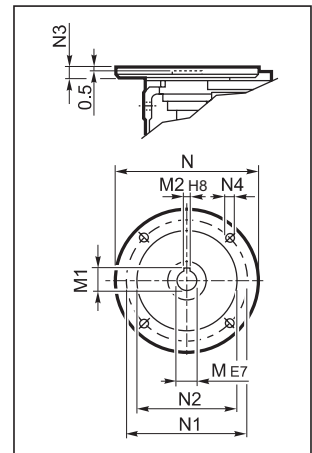

		M	M1	M2	N	N1	N2	N3	N4	P	
W/VF 63/130	P71 B5	14	16.3	5	160	130	110	11	9	95	57
W/VF 63/130	P80 B5	19	21.8	6	200	165	130	12	11.5	102	
W/VF 63/130	P90 B5	24	27.3	8	200	165	130	12	11.5	102	
W/VF 63/130	P71 B14	14	16.3	5	105	85	70	11	6.5	95	
W/VF 63/130	P80 B14	19	21.8	6	120	100	80	11	6.5	102	
W/VF 63/130	P90 B14	24	27.3	8	140	115	95	11	8.5	102	



VF 150...P (IEC)

A

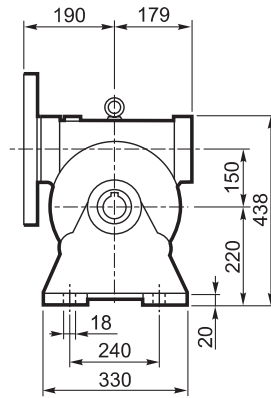
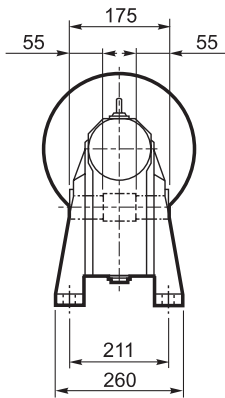

INPUT

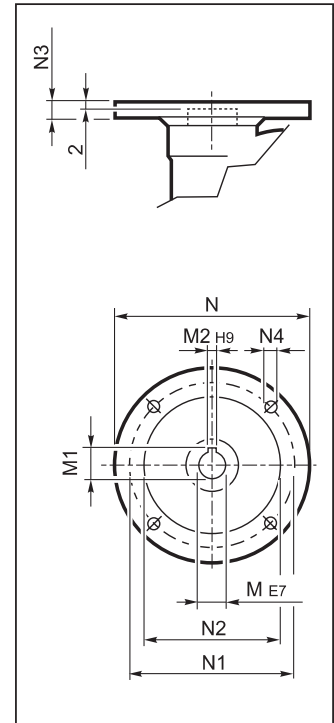

N

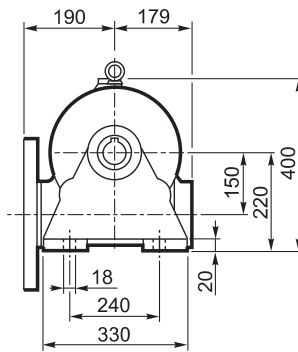
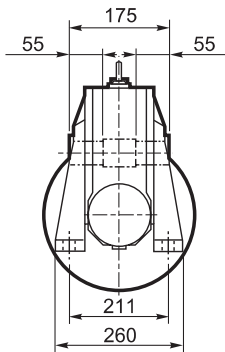

OUTPUT

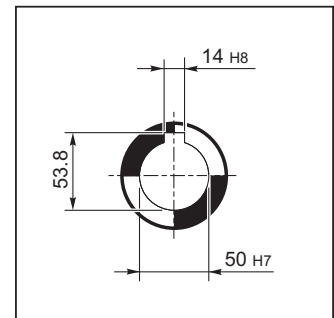

V

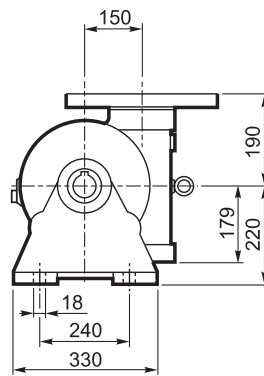
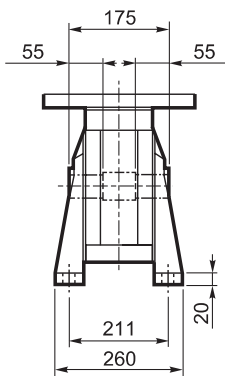



VF 150...P (IEC)

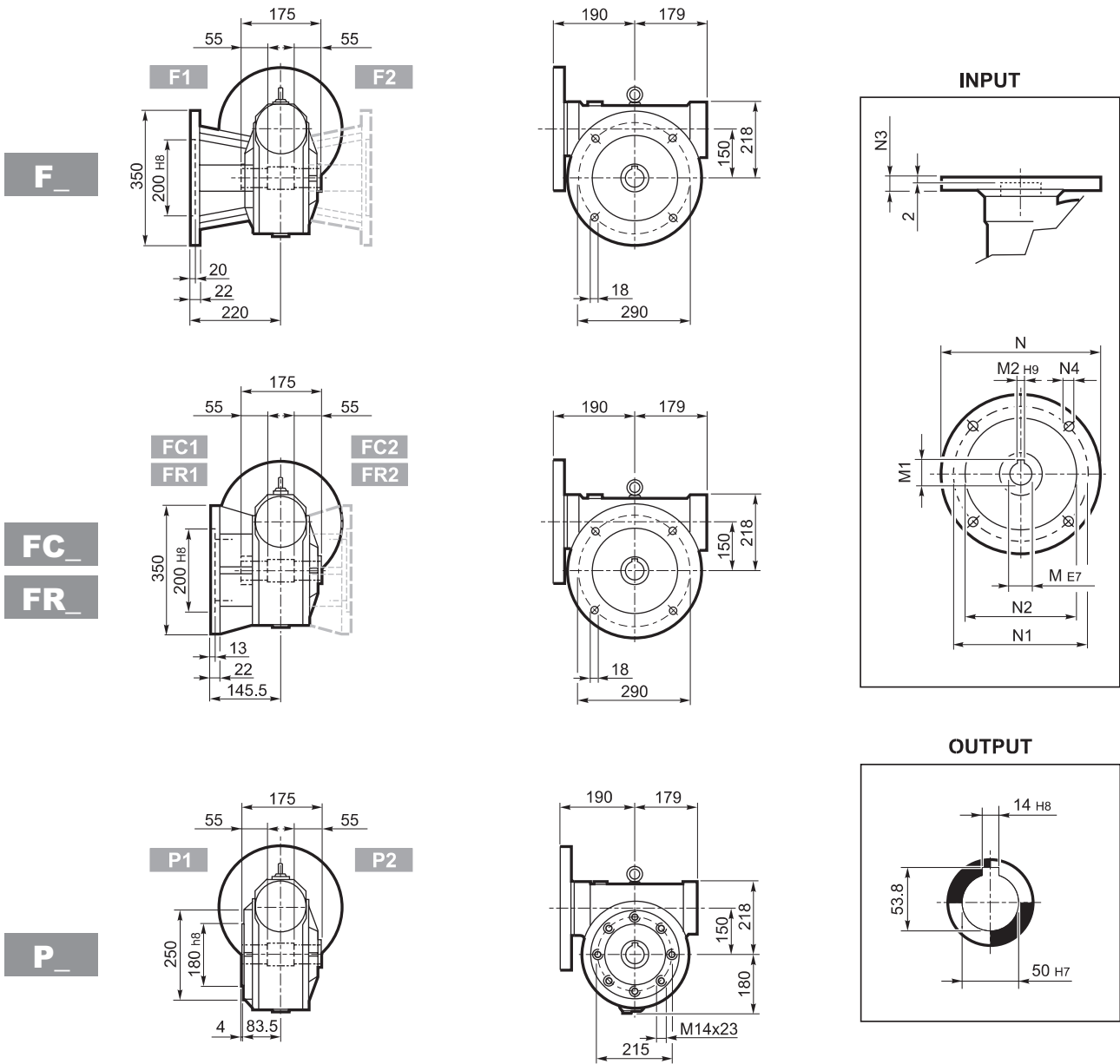

		M	M1	M2	N	N1	N2	N3	N4	
VF 150	P100 B5	28	31.3	8	250	215	180	11	13	60
VF 150	P112 B5	28	31.3	8	250	215	180	11	13	
VF 150	P132 B5	38	41.3	10	300	265	230	16	13	
VF 150	P160 B5	42	44.6#	12	350	300	250	18	18	

Verkleinertes Paßfeder



VFR 150...P (IEC)

A

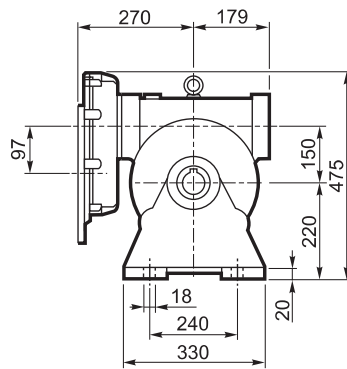
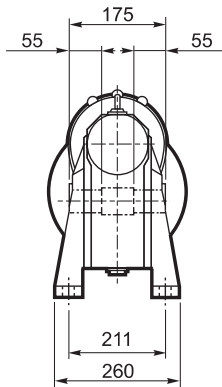

INPUT

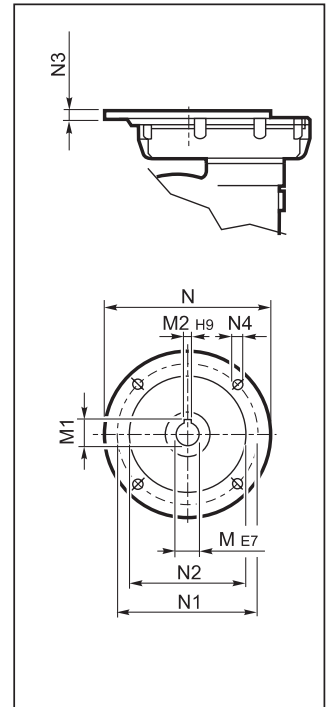

N

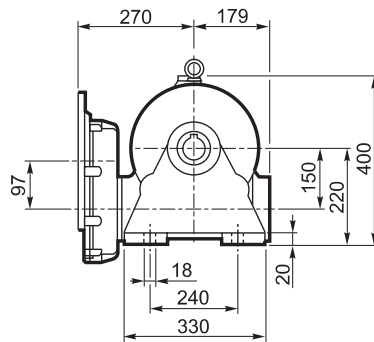
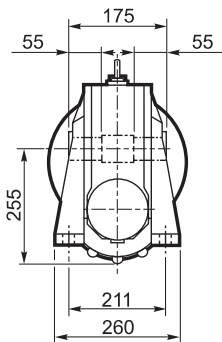

OUTPUT

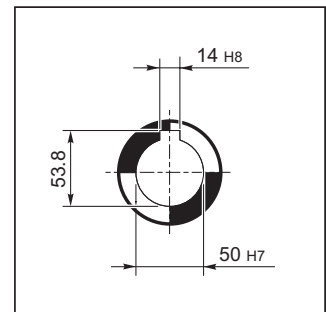

V

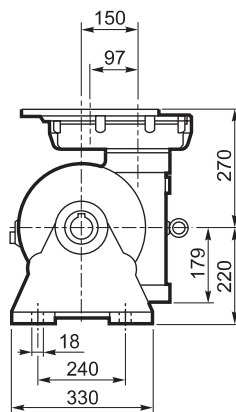
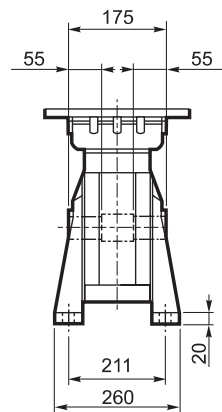

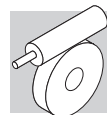

VFR 150...P (IEC)

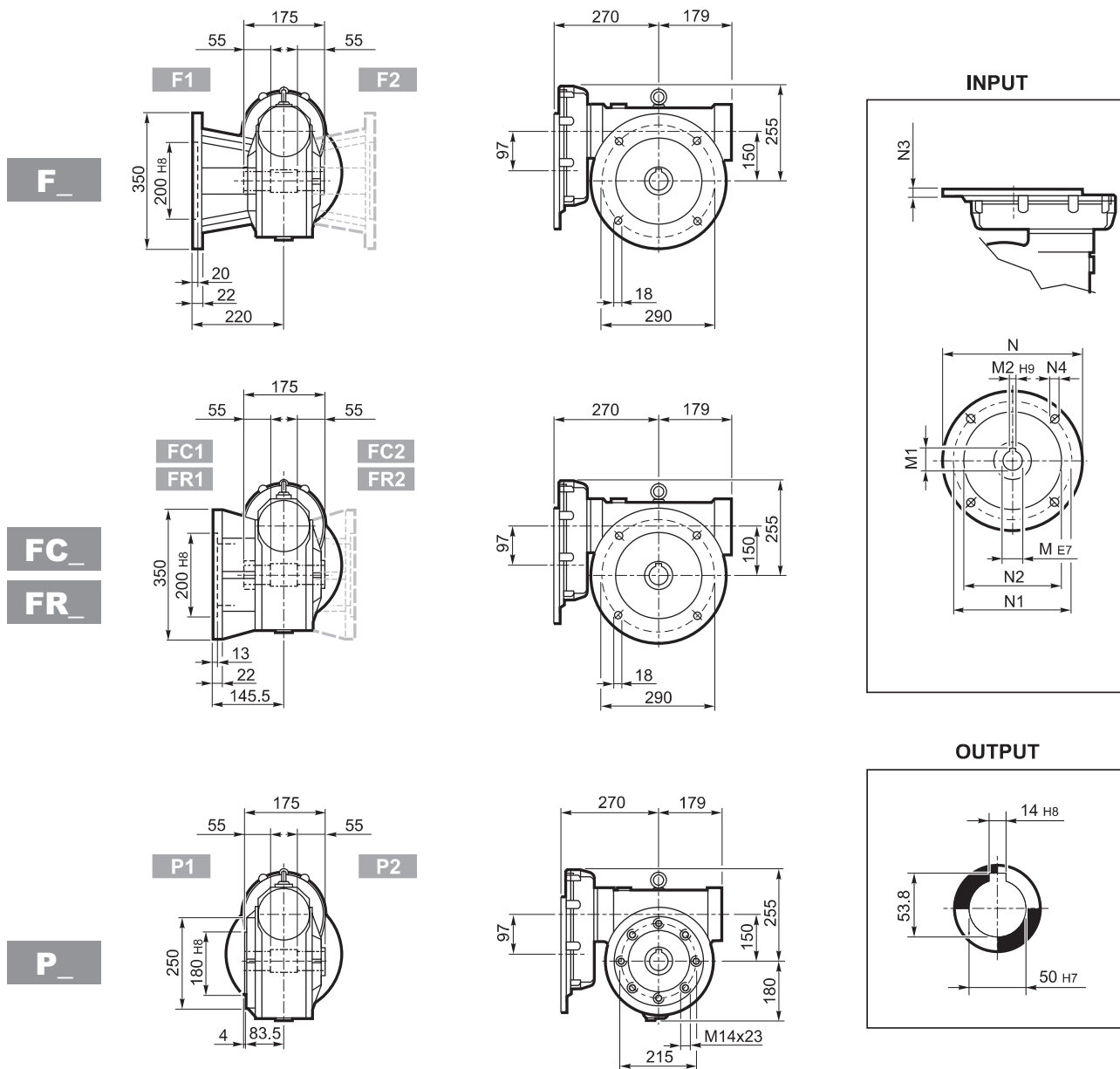

		M	M1	M2	N	N1	N2	N3	N4	
VFR 150	P90 B5	24 K6	27.3	8	200	165	130	13	M10x25	71
VRF 150	P100 B5	28 K6	31.3	8	250	215	180	13	M12x35	
VRF 150	P112 B5	28 J6	31.3	8	250	215	180	13	M12x35	
VFR 150	P132 B5	38 J6	39.6#	10	300	265	230	13	M12x35	

Verkleinertes Paßfeder



W/VF 86/150...M/ME

A

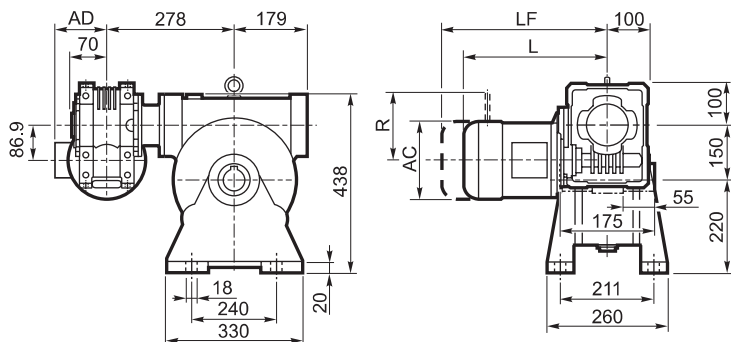

F_

FC_

FR_

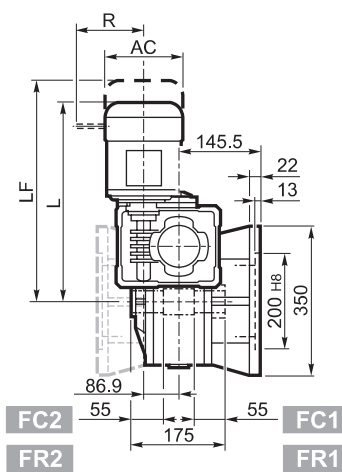
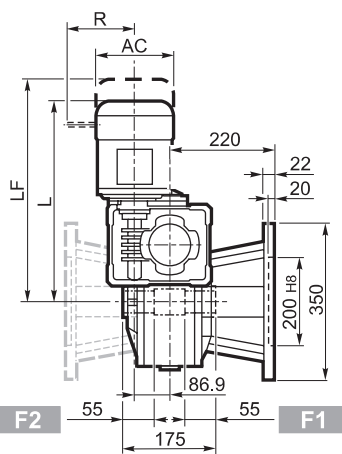
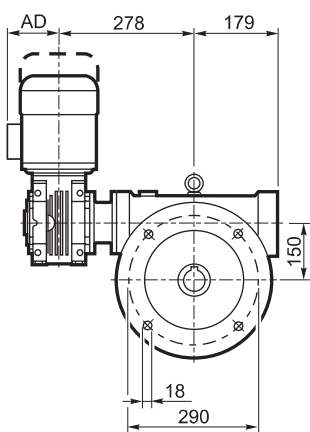

P_

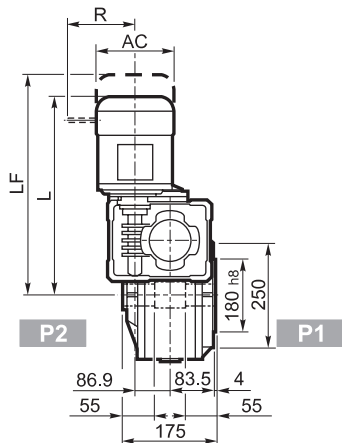
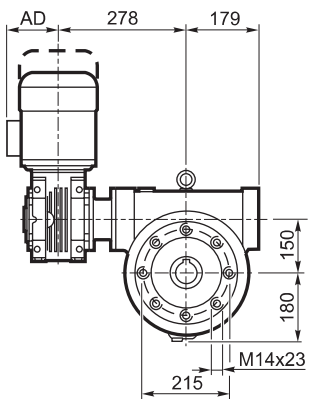

OUTPUT

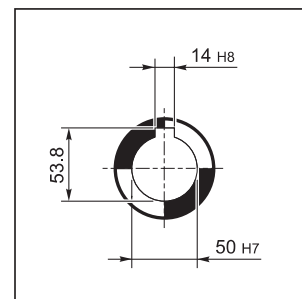

			M/ME				M...FD M...FA		M...FD		M...FA	
			AC	L	AD	Kg	LF	Kg	R	AD	R	AD
W/VF 86/150	S1	M1	138	474	108	82	385	84	103	135	124	108
W/VF 86/150	S2	ME2S	156	499	119	86	—	—	—	—	—	—
W/VF 86/150	S3	ME3S	193	542	142	92.5	—	—	—	—	—	—
W/VF 86/150	S3	ME3L	193	574	142	98	—	—	—	—	—	—



W/VF 86/150...P (IEC)

INPUT

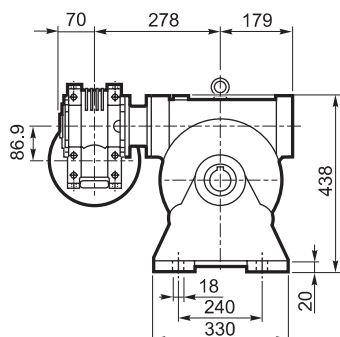

A

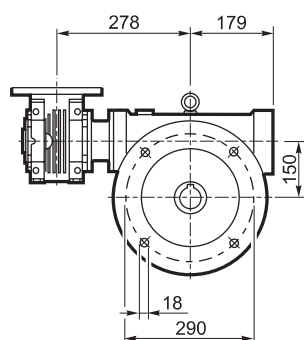
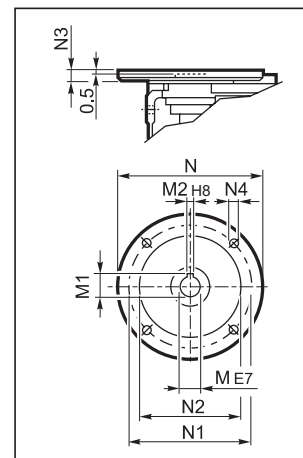
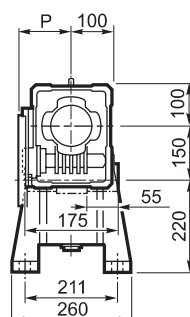

F

FC

FR

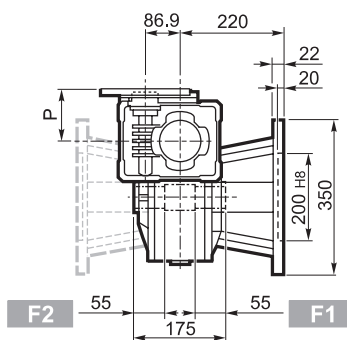

F2

F1

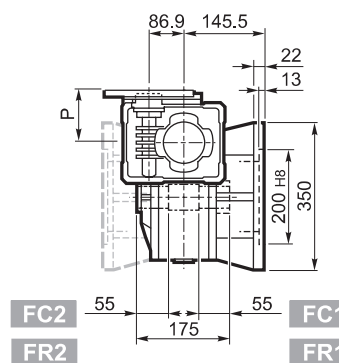

FC2

FC1

FR2

FR1

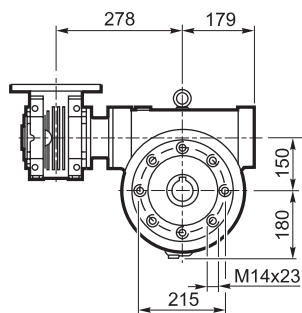

P

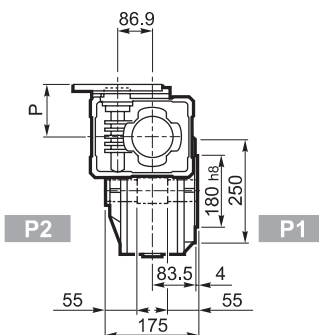

P2

P1

OUTPUT

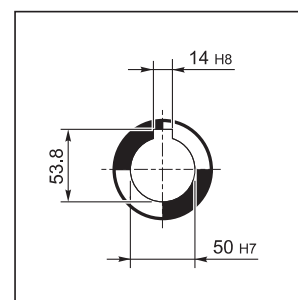

		M	M1	M2	N	N1	N2	N3	N4	P	
W/VF 86/150	P71 B5	14	16.3	5	160	130	110	11	9	128	75
W/VF 86/150	P80 B5	19	21.8	6	200	165	130	12	11.5	128	
W/VF 86/150	P90 B5	24	27.3	8	200	165	130	12	11.5	128	
W/VF 86/150	P100 B5	28	31.3	8	250	215	180	13	12.5	136	
W/VF 86/150	P112 B5	28	31.3	8	250	215	180	13	12.5	136	
W/VF 86/150	P80 B14	19	21.8	6	120	100	80	7.5	6.5	128	
W/VF 86/150	P90 B14	24	27.3	8	140	115	95	7.5	8.5	128	
W/VF 86/150	P100 B14	28	31.3	8	160	130	110	10	8.5	136	
W/VF 86/150	P112 B14	28	31.3	8	160	130	110	10	8.5	136	



VF 185...P (IEC)

A

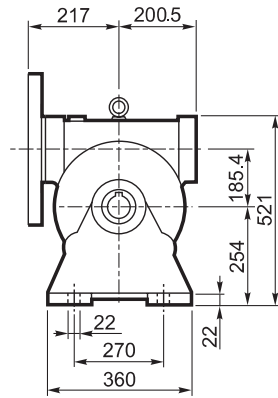
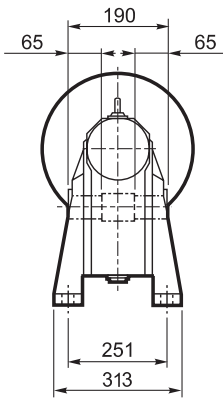

N

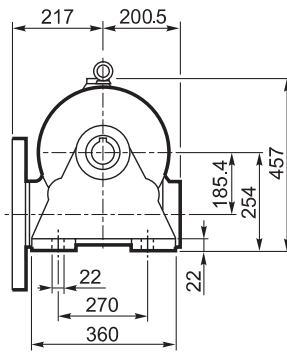
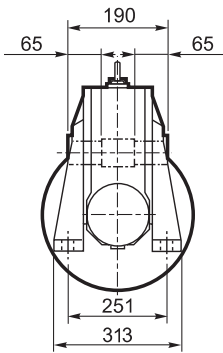

V

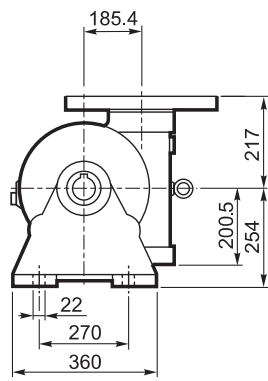
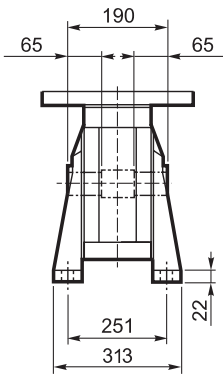

INPUT

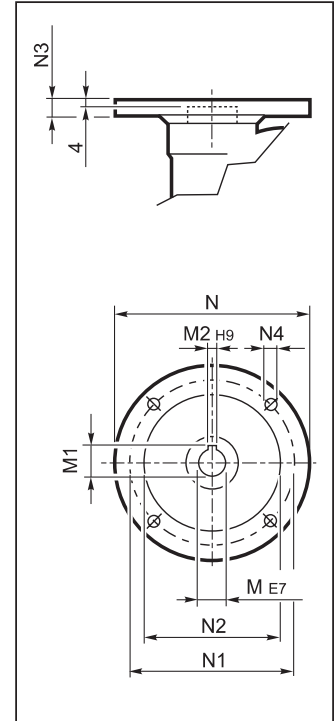

OUTPUT

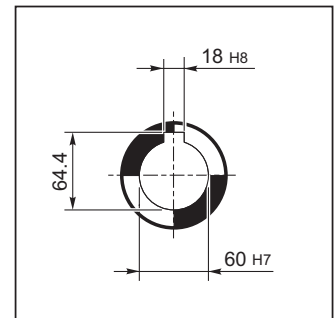



VF 185...P (IEC)

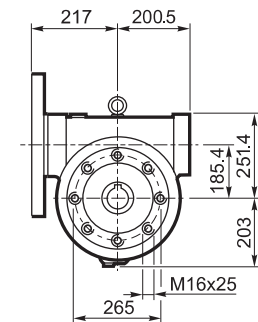
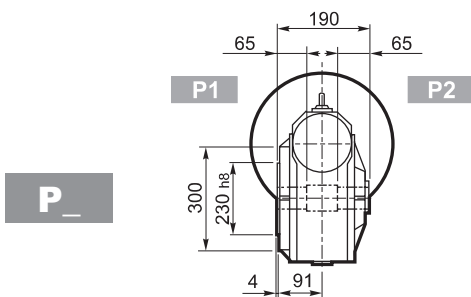
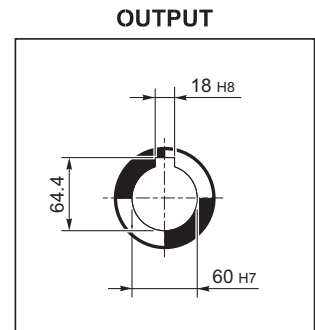
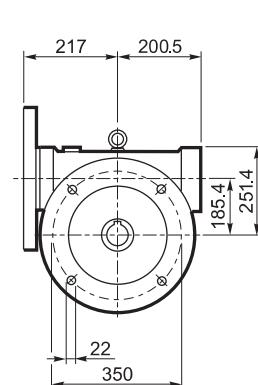
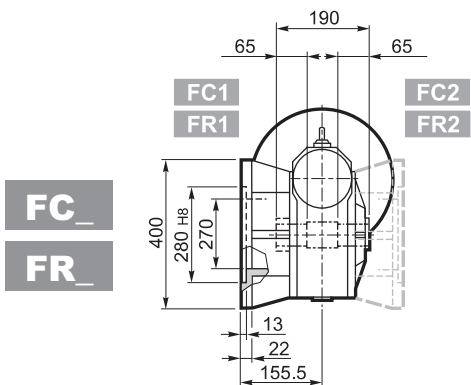
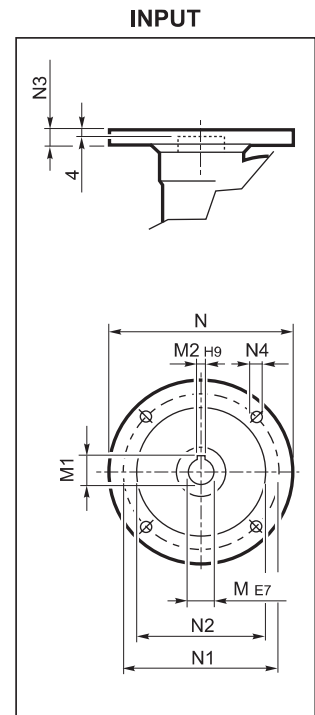
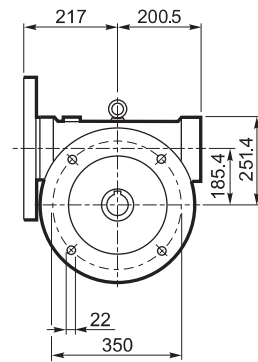
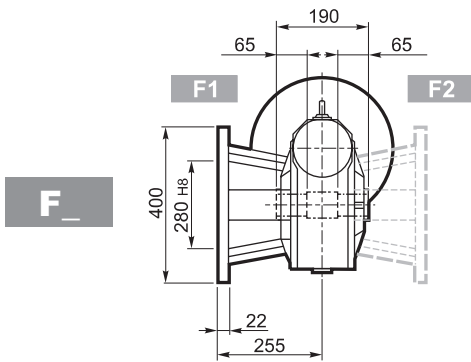

		M	M1	M2	N	N1	N2	N3	N4	Kg
VF 185	P100 B5	28	31.3	8	250	215	180	16	13	94
VF 185	P112 B5	28	31.3	8	250	215	180	16	13	
VF 185	P132 B5	38	41.3	10	300	265	230	16	13	
VF 185	P160 B5	42	45.3	12	350	300	250	18	18	
VF 185	P180 B5	48	51.2#	14	350	300	250	18	18	

Verkleinertes Paßfeder



VFR 185...P (IEC)

A

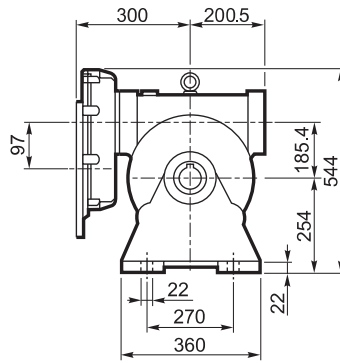
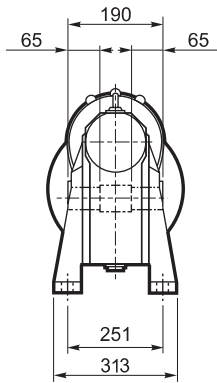

N

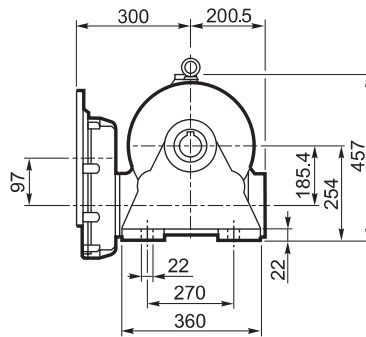
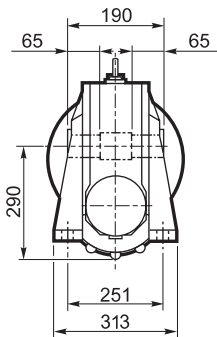

V

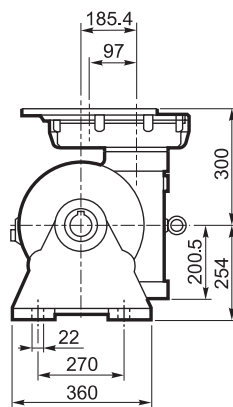
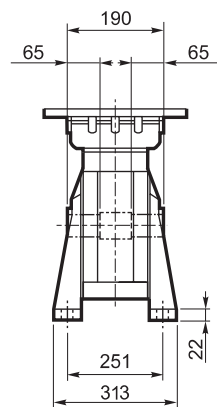

INPUT

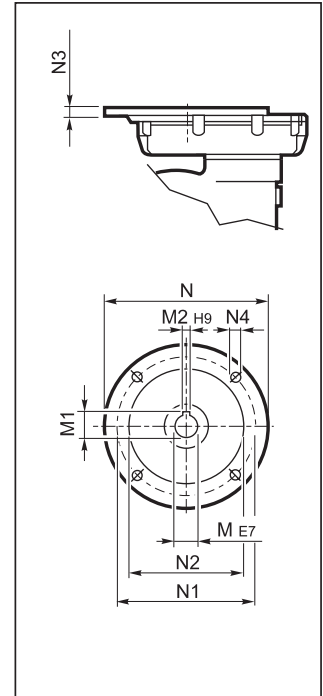

OUTPUT

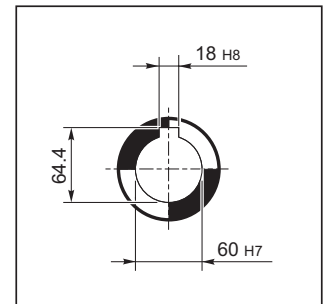



VFR 185...P (IEC)

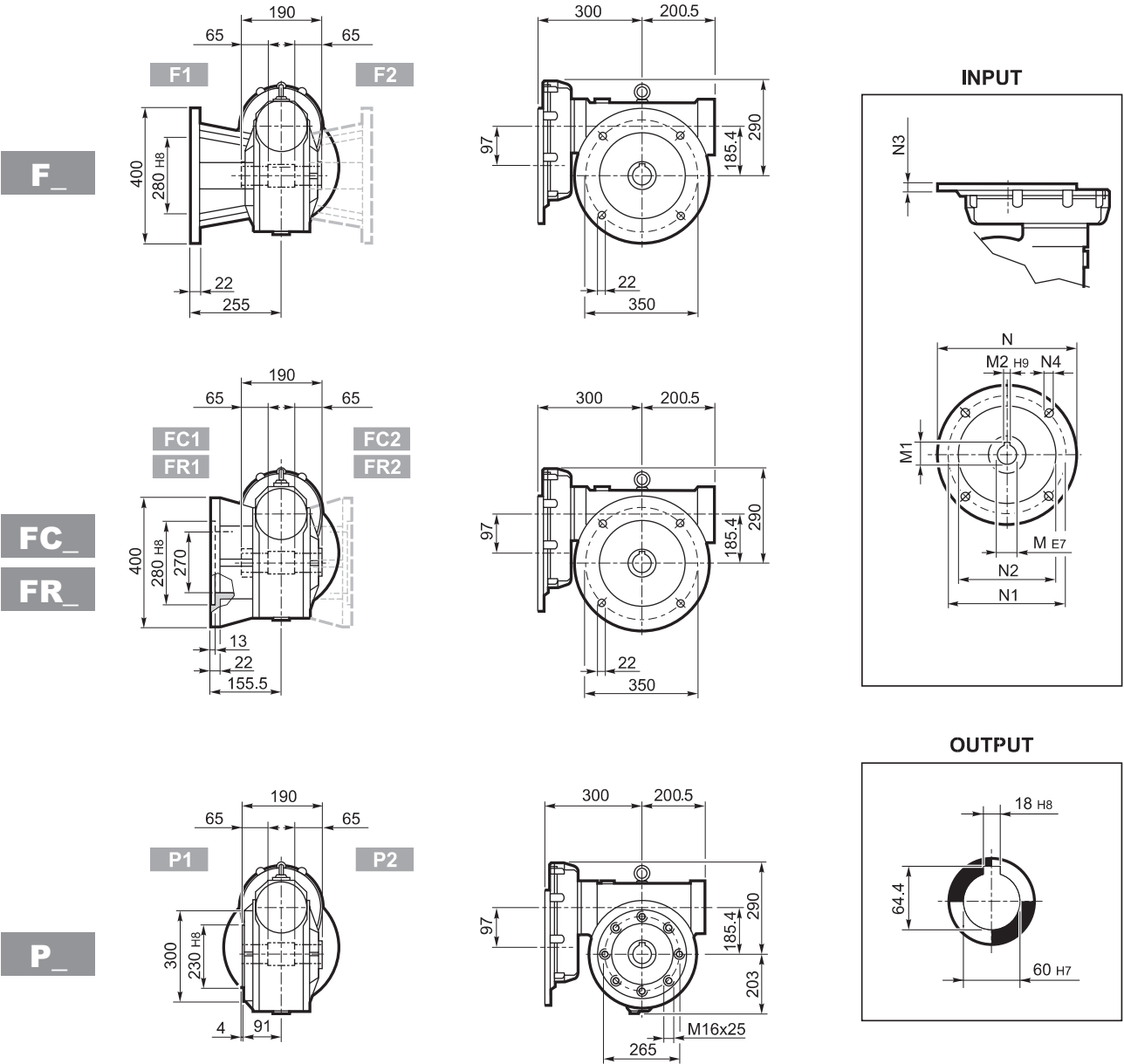

		M	M1	M2	N	N1	N2	N3	N4	
VFR 185	P90 B5	24 K6	27.3	8	200	165	130	13	M10x25	110
VRF 185	P100 B5	28 K6	31.3	8	250	215	180	13	M12x35	
VRF 185	P112 B5	28 K6	31.3	8	250	215	180	13	M12x35	
VFR 185	P132 B5	38 J6	39.6#	10	300	265	230	13	M12x35	

Verkleinertes Paßfeder



W/VF 86/185...M/ME

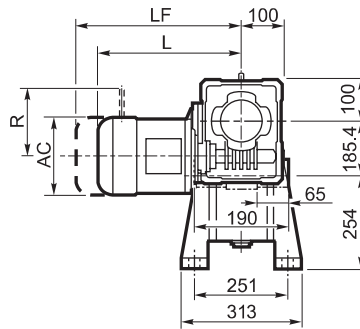
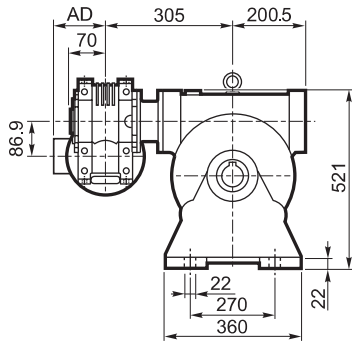

A

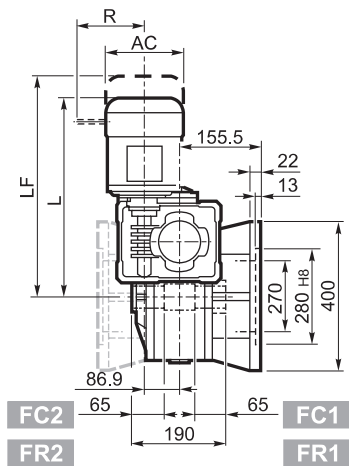
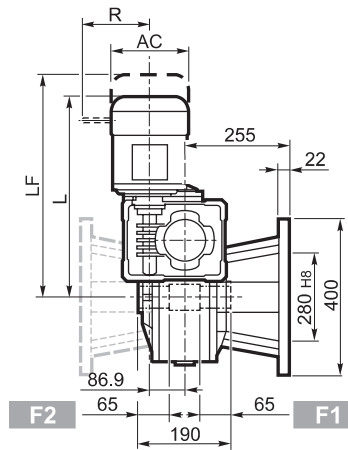
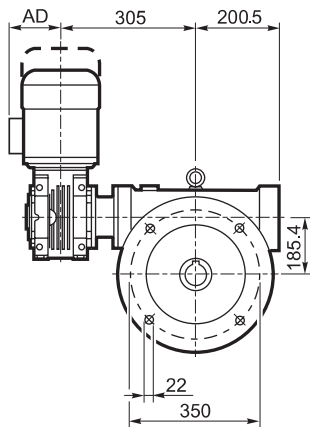

F_

FC_

FR_

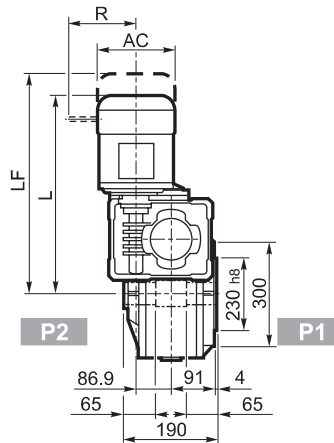
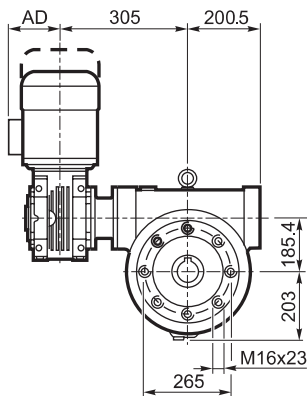

P_

OUTPUT

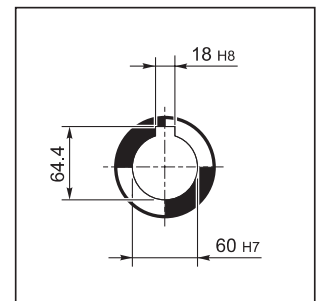

			M/ME				M...FD M...FA		M...FD		M...FA	
			AC	L	AD	Kg	LF	Kg	R	AD	R	AD
W/VF 86/185	S1	M1	138	509	108	116	570	118	103	135	124	108
W/VF 86/185	S2	ME2S	156	534	119	120	—	—	—	—	—	—
W/VF 86/185	S3	ME3S	193	577	142	126.5	—	—	—	—	—	—
W/VF 86/185	S3	ME3L	193	609	142	132	—	—	—	—	—	—



W/VF 86/185...P (IEC)

A

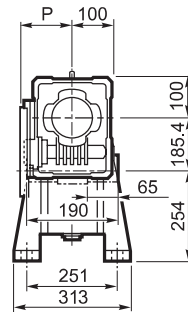
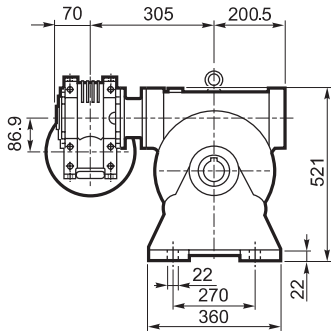

INPUT

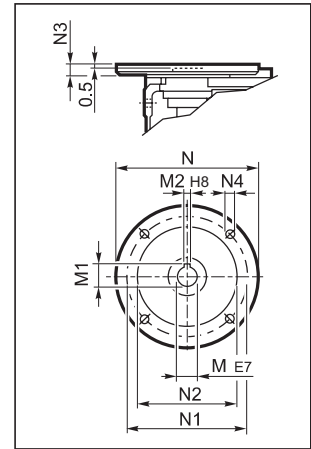

F_

FC_

FR_

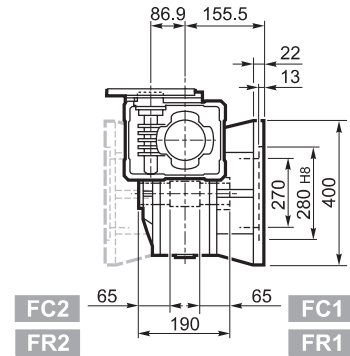
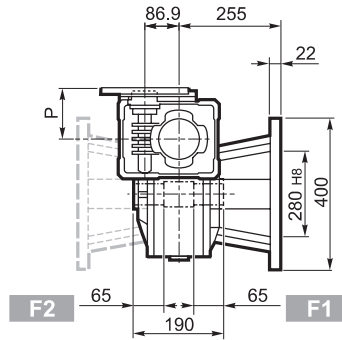
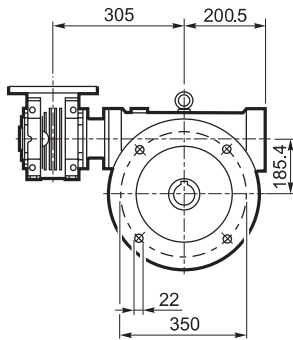

P_

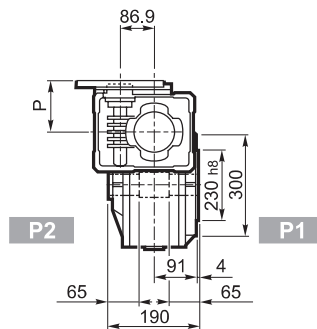
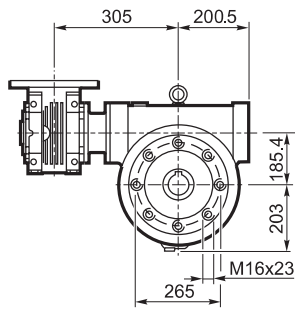

OUTPUT

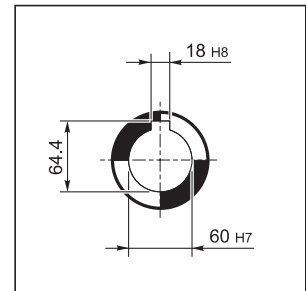

		M	M1	M2	N	N1	N2	N3	N4	P	
W/VF 86/185	P71 B5	14	16.3	5	160	130	110	11	9	128	109
W/VF 86/185	P80 B5	19	21.8	6	200	165	130	12	11.5	128	
W/VF 86/185	P90 B5	24	27.3	8	200	165	130	12	11.5	128	
W/VF 86/185	P100 B5	28	31.3	8	250	215	180	13	12.5	136	
W/VF 86/185	P112 B5	28	31.3	8	250	215	180	13	12.5	136	
W/VF 86/185	P80 B14	19	21.8	6	120	100	80	7.5	6.5	128	
W/VF 86/185	P90 B14	24	27.3	8	140	115	95	7.5	8.5	128	
W/VF 86/185	P100 B14	28	31.3	8	160	130	110	10	8.5	136	
W/VF 86/185	P112 B14	28	31.3	8	160	130	110	10	8.5	136	



VF 210...P (IEC)

A

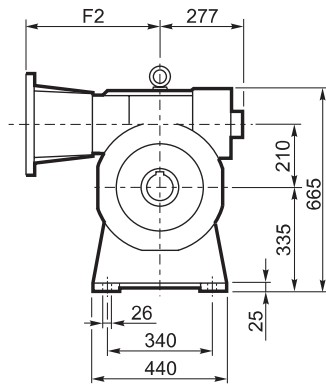
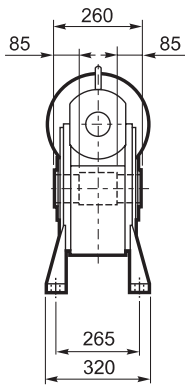

N

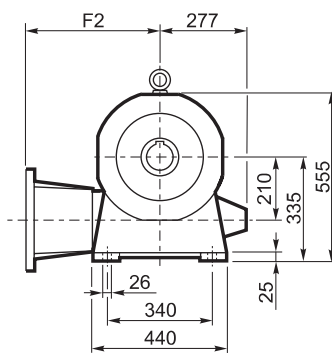
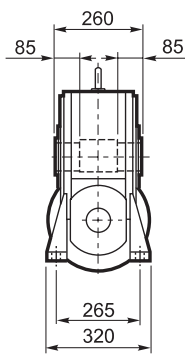

INPUT

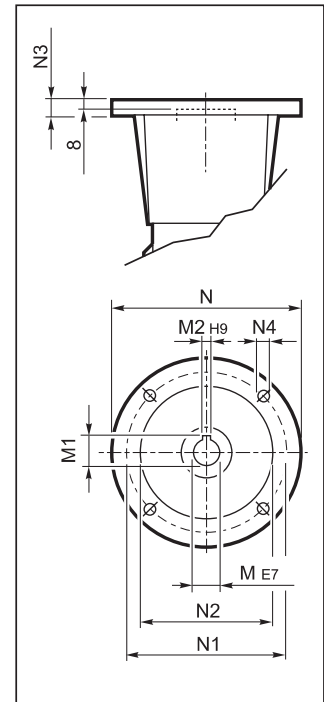

OUTPUT

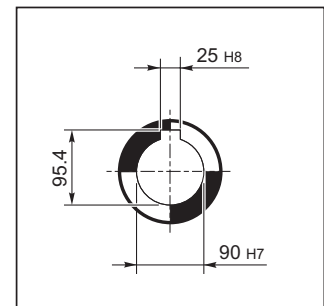

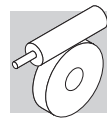

VF 210...P (IEC)

V

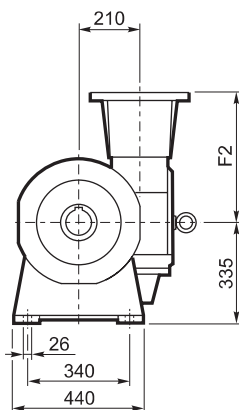
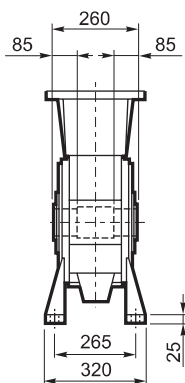

P

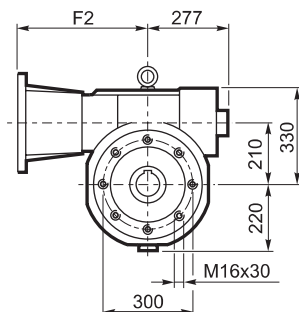
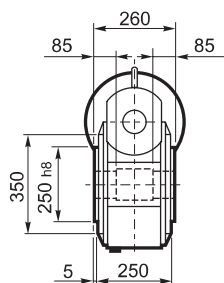

INPUT

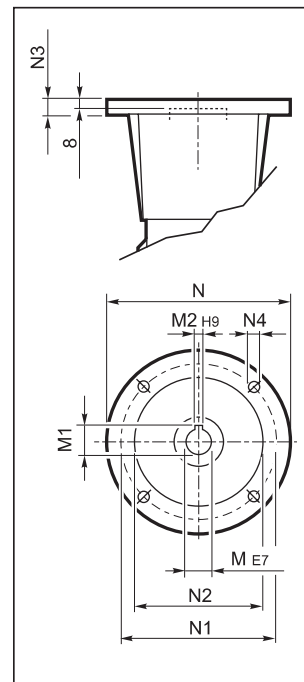

OUTPUT

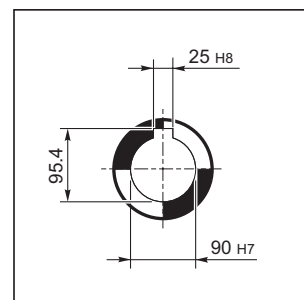

In den Ausführungen A und P wird das Lüferrad eingebaut.
Die Motorflansch-Ausführung wird serienmäßig mit kompletter Motorkupplung geliefert.

		F2	M	M1	M2	N	N1	N2	N3	N4	
VF 210	P132 B5	485	38	41.3	10	300	265	230	25	M12	210
VF 210	P160 B5	460	42	45.3	12	350	300	250	22	18	
VF 210	P180 B5	460	48	51.8	14	350	300	250	22	18	
VF 210	P200 B5	485	55	59.3	16	400	350	300	25	M16	
VF 210	P225 B5	490	60	64.4	18	450	400	350	22	18 #	

N. 8 Bohrungen 45°



VFR 210...P (IEC)

A

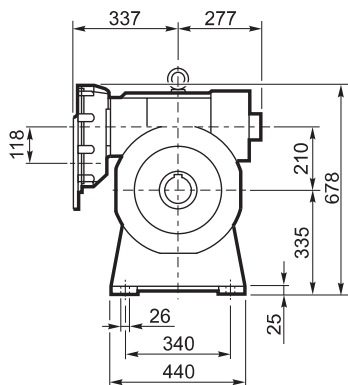
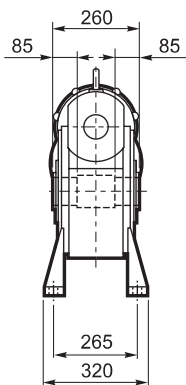

N

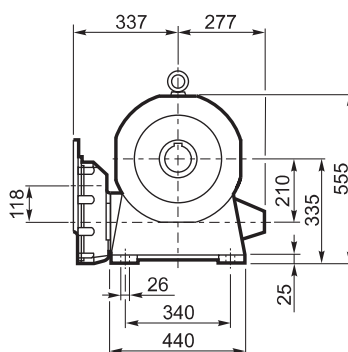
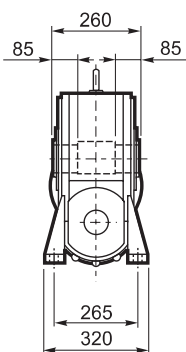

INPUT

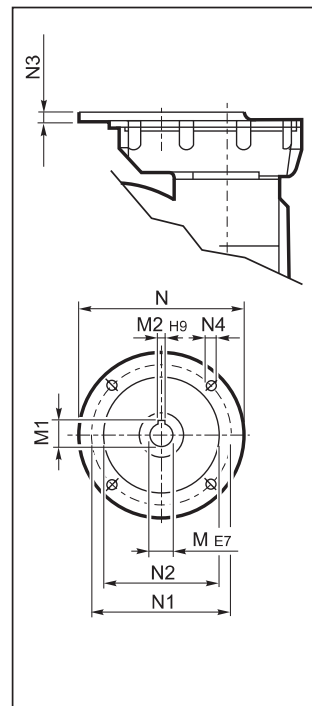

OUTPUT

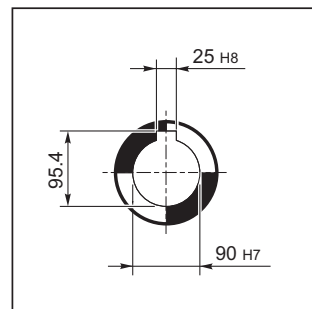



VFR 210...P (IEC)

V

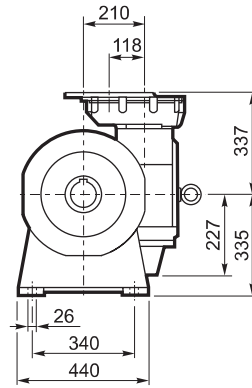
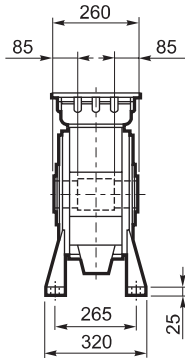

P

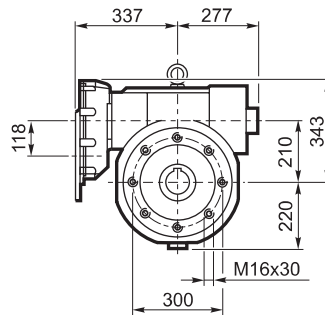
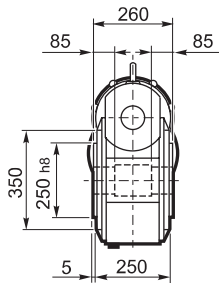

INPUT

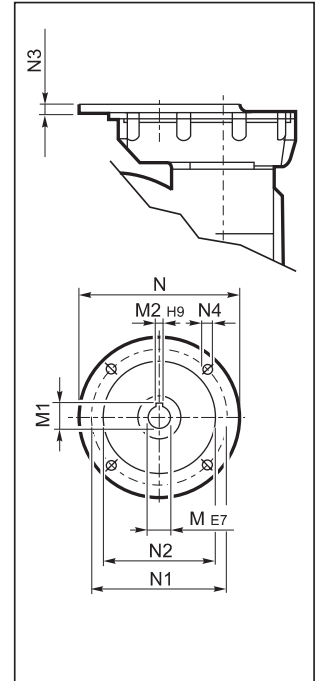

OUTPUT

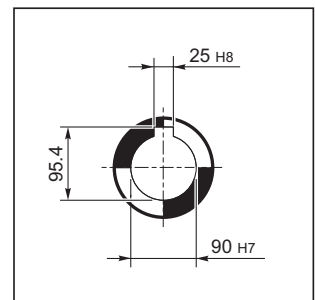

In den Ausführungen A und P wird das Lüfterrad eingebaut.

		M	M1	M2	N	N1	N2	N3	N4	Kg
VRF 210	P100 B5	28 K6	31.3	8	250	215	180	13	M12x35	185
VRF 210	P112 B5	28 K6	31.3	8	250	215	180	13	M12x35	
VFR 210	P132 B5	38 J6	41.3	10	300	265	230	13	M12x35	
VFR 210	P160 B5	42 J6	44.3#	12	350	300	250	18	M16x60	

Verkleinertes Paßfeder



VF/VF 130/210...P (IEC)

A

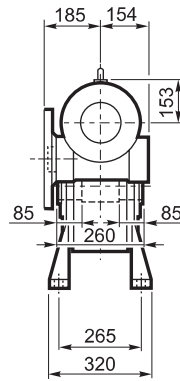
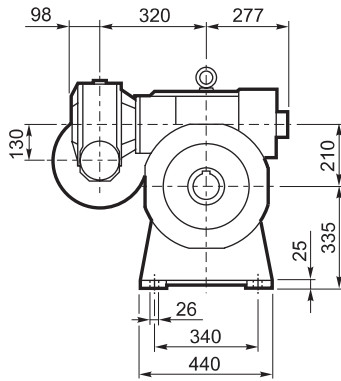

P

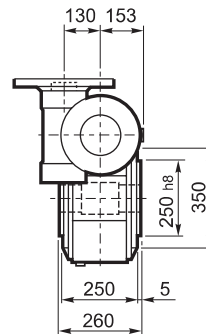
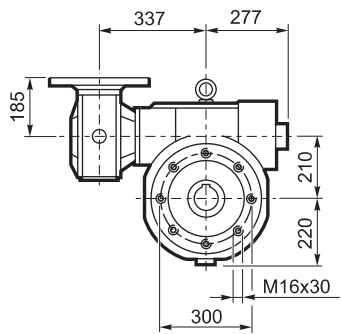

INPUT

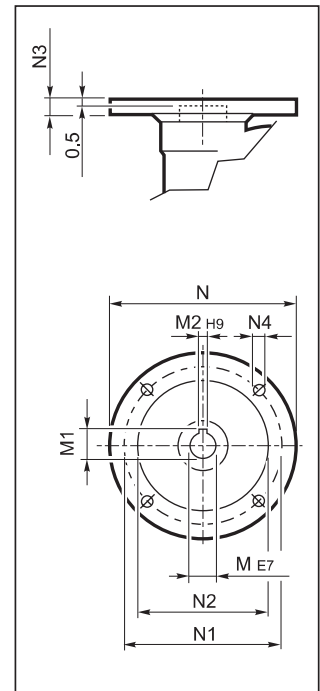

OUTPUT

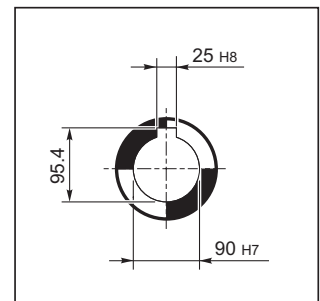

In den Ausführungen A und P wird das Lüfterrad eingebaut.

		M	M1	M2	N	N1	N2	N3	N4	
VF/VF 130/210	P90 B5	24	27.3	8	200	165	130	17	11	225
VF/VF 130/210	P100 B5	28	31.3	8	250	215	180	17	13	
VF/VF 130/210	P112 B5	28	31.3	8	250	215	180	17	13	
VF/VF 130/210	P132 B5	38	40.1#	10	300	265	230	17	13	

Verkleinertes Paßfeder

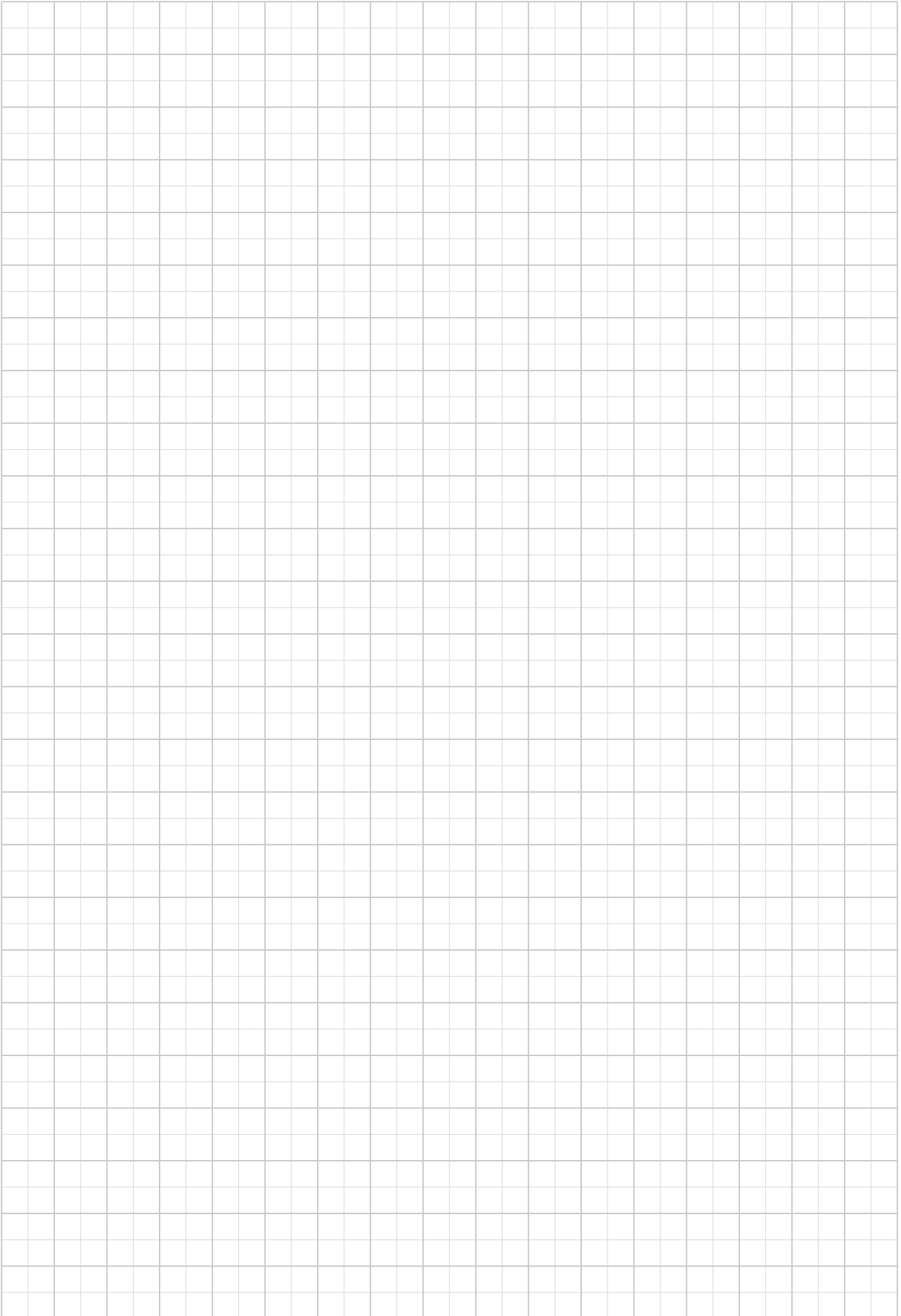
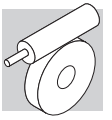



VF 250...P (IEC)

A

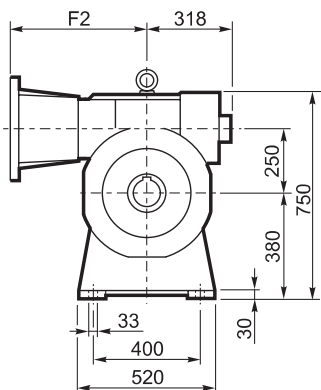
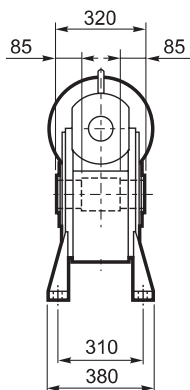

N

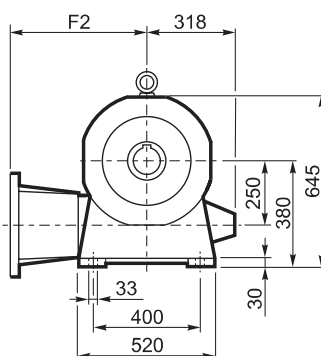
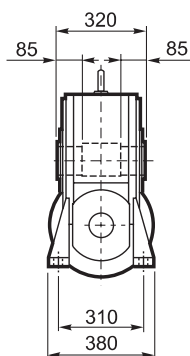

INPUT

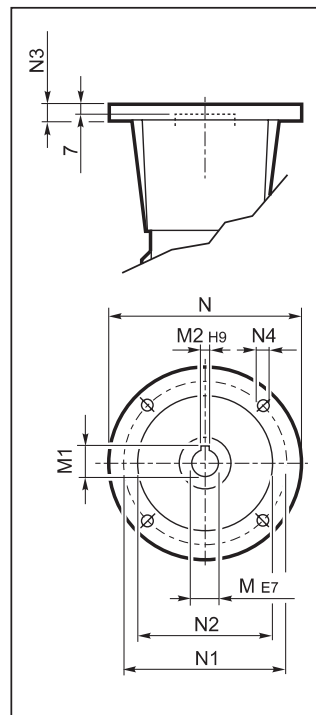

OUTPUT

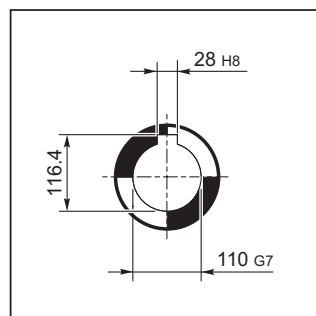

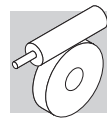

VF 250...P (IEC)

V

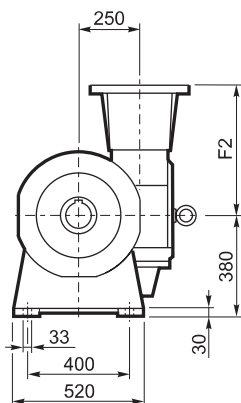
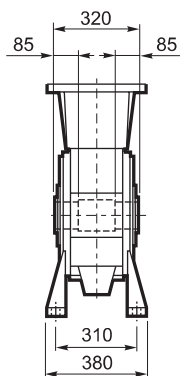

P

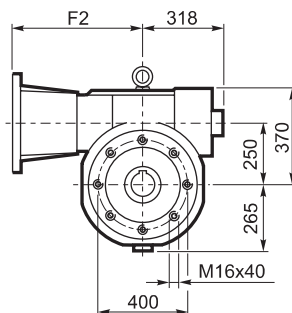
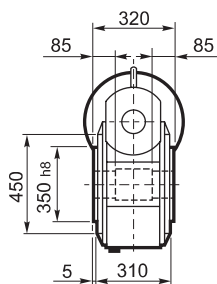

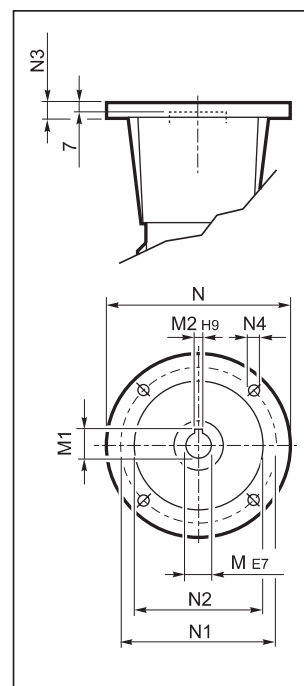

INPUT

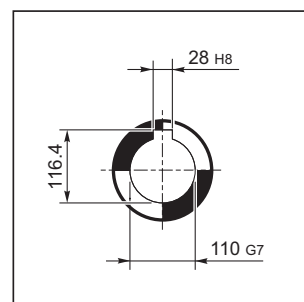

OUTPUT



In den Ausführungen A und P wird das Lüfterrad eingebaut.
Die Motorflansch-Ausführung wird serienmäßig mit kompletter Motorkupplung geliefert.

		F2	M	M1	M2	N	N1	N2	N3	N4	
VF 250	P132 B5	531	38	41.3	10	300	265	230	25	M12	310
VF 250	P160 B5	506	42	45.3	12	350	300	250	22	18	
VF 250	P180 B5	506	48	51.8	14	350	300	250	22	18	
VF 250	P200 B5	531	55	59.3	16	400	350	300	25	M16	
VF 250	P225 B5	536	60	64.4	18	450	400	350	22	18#	

N. 8 Bohrungen 45°



VFR 250...P (IEC)

A

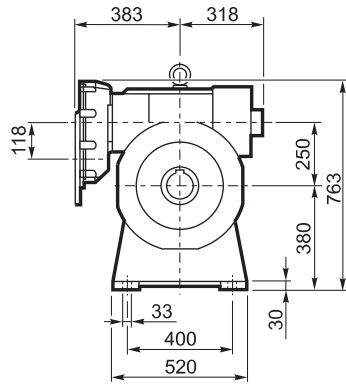
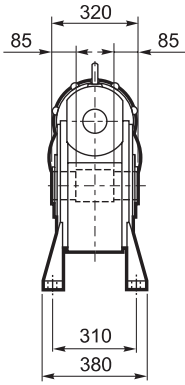

N

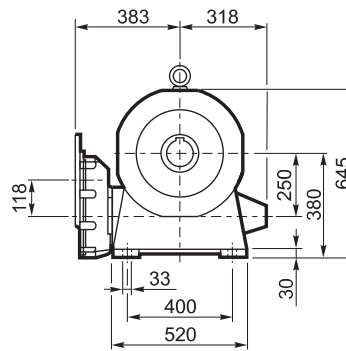
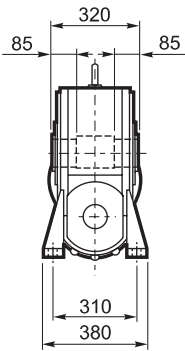

INPUT

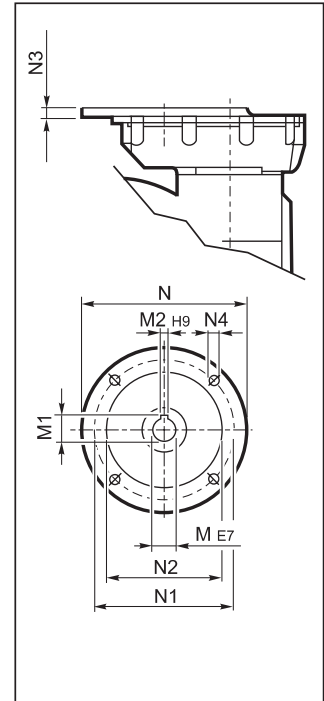

OUTPUT

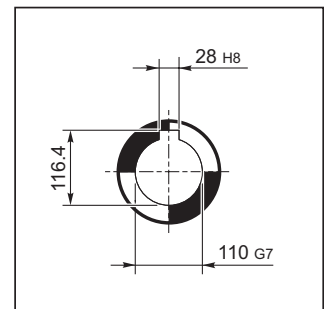



VFR 250...P (IEC)

V

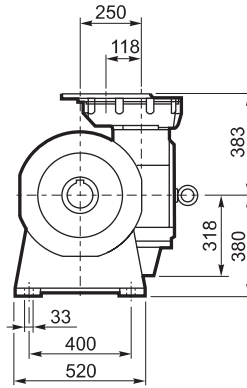
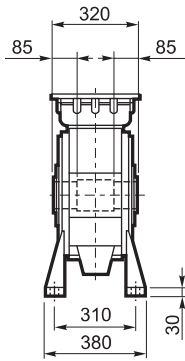

P

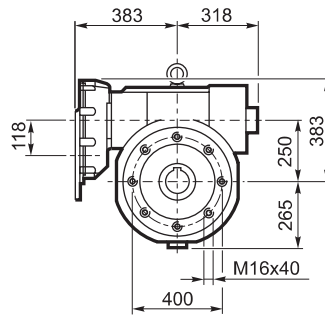
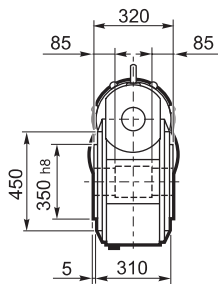

INPUT

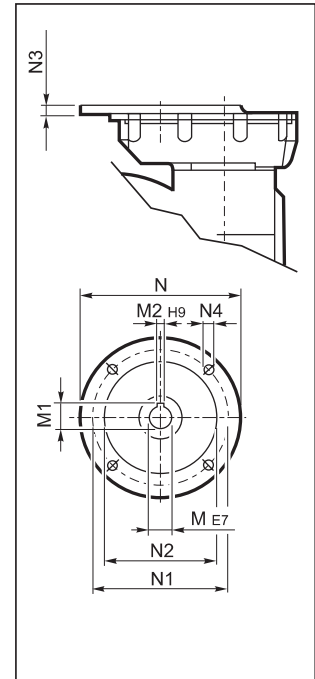

OUTPUT

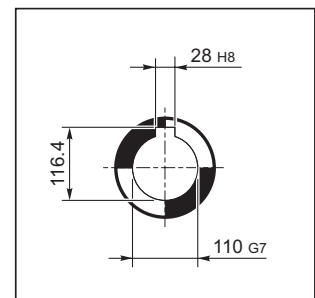

In den Ausführungen A und P wird das Lüfterrad eingebaut.

		M	M1	M2	N	N1	N2	N3	N4	
VRF 250	P100 B5	28 K6	31.3	8	250	215	180	13	M12x35	295
VRF 250	P112 B5	28 K6	31.3	8	250	215	180	13	M12x35	
VFR 250	P132 B5	38 J6	41.3	10	300	265	230	13	M12x35	
VFR 250	P160 B5	42 J6	44.3#	12	350	300	250	18	M16x60	

Verkleinertes Paßfeder



VF/VF 130/250...P (IEC)

A

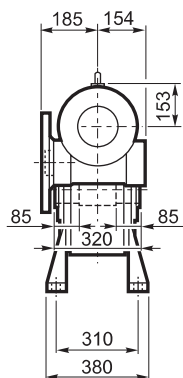
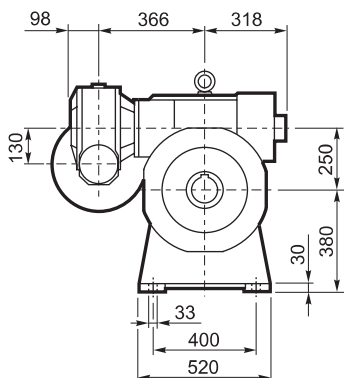

P

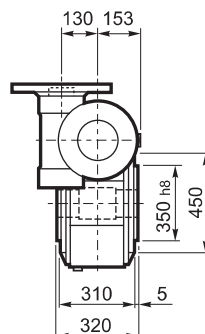
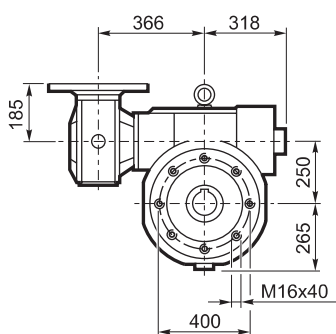

INPUT

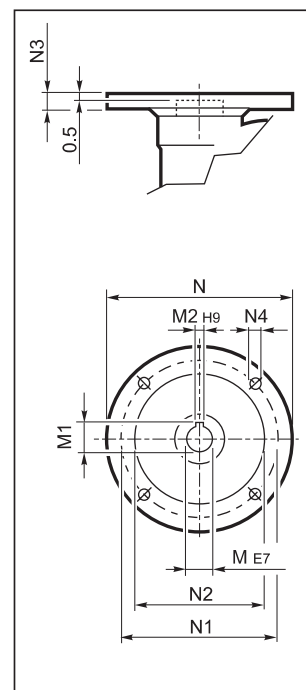

OUTPUT

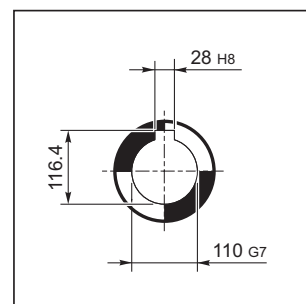

In den Ausführungen A und P wird das Lüfterrad eingebaut.

		M	M1	M2	N	N1	N2	N3	N4	
VF/VF 130/250	P 90 B5	24	27.3	8	200	165	130	17	11	325
VF/VF 130/250	P100 B5	28	31.3	8	250	215	180	17	13	
VF/VF 130/250	P112 B5	28	31.3	8	250	215	180	17	13	
VF/VF 130/250	P132 B5	38	40.1#	10	300	265	230	17	13	

Verkleinertes Paßfeder



27 ABMESSUNGEN FÜR GETRIEBEN MIT CYLINDRISCHER ANTRIEBSWELLE

VF 27...HS

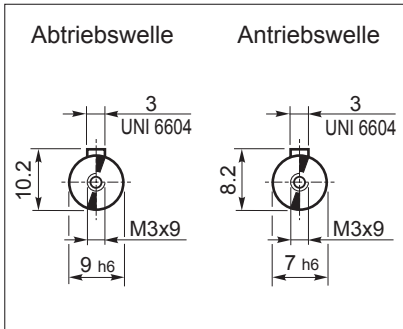

VF 27_A..HS

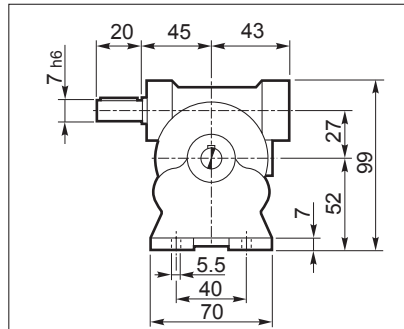

VF 27_N..HS

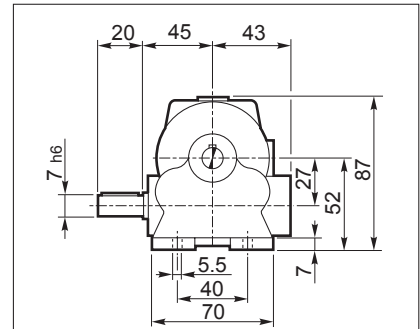

VF 27_V..HS

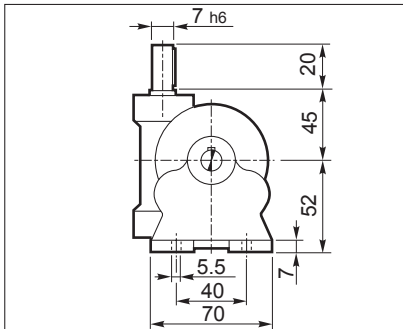

VF 27_F1..HS

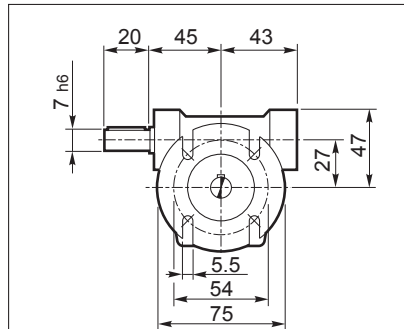

VF 27_F2..HS

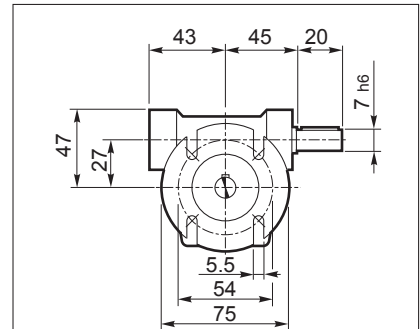

VF 27_HS	0.73

Die mit den anderen Konfigurationen gemeinen Abmessungen sind auf Seiten 105.



VF...HS - W...HS

VF_A..HS

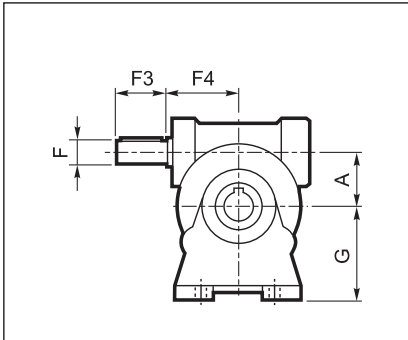

VF_V..HS

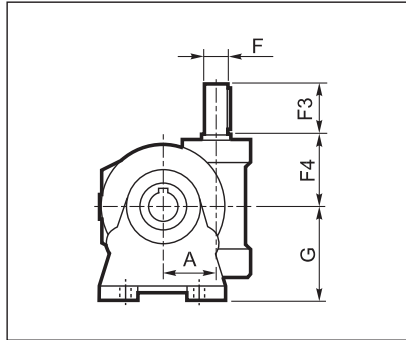

VF_N..HS

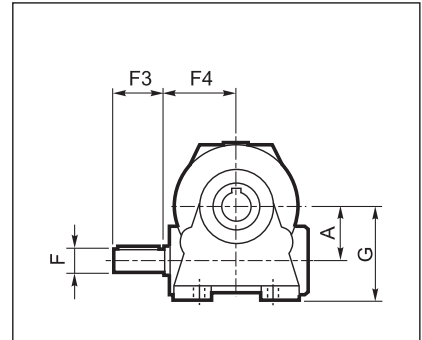

VF_P..HS

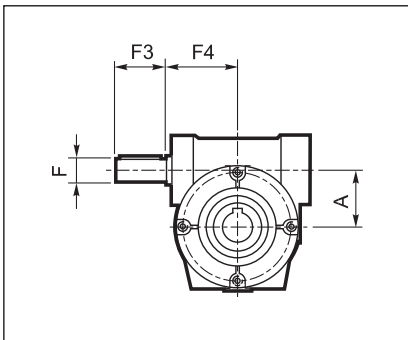

VF_FA/FC/FR/F..HS

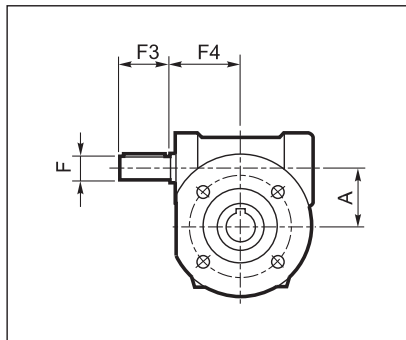

VF_U..HS

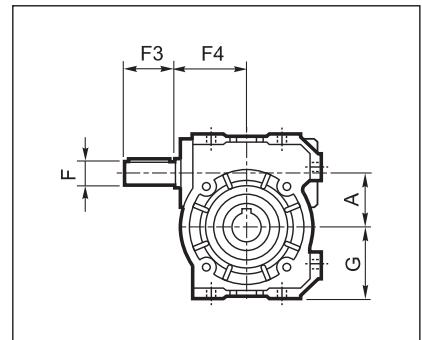

W_U..HS

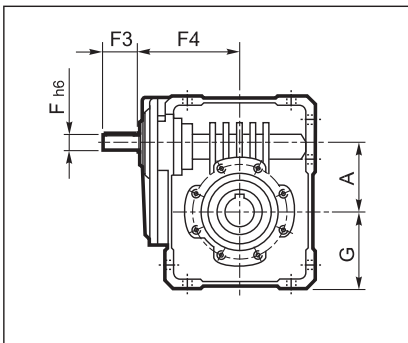

W_UF/UFC/UFCR..HS

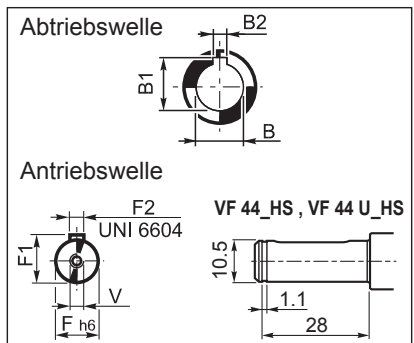
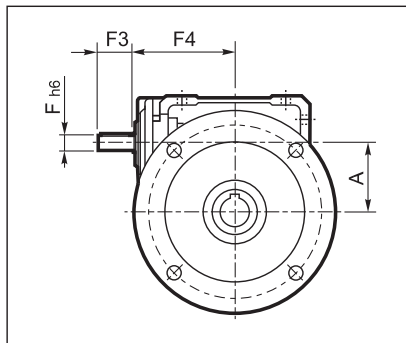

	A	B	B1	B2	F	F1	F2	F3	F4	G	V	kg
VF 30_HS	30	14 H7	16.3	5	9	10.2	3	20	50	55	—	1.1
VF 30_U_HS										47		
VF 44_HS	44.6	18 H7	20.8	6	11	12.5	4	30	54	72	—	2.0
VF 44_U_HS										55		
VF 49_HS	49.5	25 H7	28.3	8	16	18	5	40	65	82	M6x16	3.0
VF 49_U_HS										64.5		
W 63_HS	62.17	25 H7	28.3	8	18	20.5	6	40	110.5	72.5	M6x16	6.4
W 75_HS	75	30(28) H7	33.3(31.3)	8	19	21.5	6	40	128	87	M6x16	10.0
W 86_HS	86.9	35 H7	38.3	10	25	28	8	50	144	100	M8x19	14.1
W 110_HS	110.1	42 H7	45.3	12	25	28	8	60	168	125	M8x19	27
VF 130_HS	130	45 H7	48.8	14	30	33	8	60	160	195	M8x20	49
VF 150_HS	150	50 H7	53.8	14	35	38	10	65	185	220	M8x20	60
VF 185_HS	185.4	60 H7	64.4	18	40	43	12	70	214.5	254	M8x20	94
VF 210_HS	210	90 H7	95.4	25	48	51.5	14	110	230	335	M16x40	175
VF 250_HS	250	110 G7	116.4	28	55	59	16	110	274	380	M16x40	275

Die mit den anderen Konfigurationen gemeinen Abmessungen sind auf Seiten 106 - 161 angegeben.



VFR...HS - WR...HS

VFR_A..HS

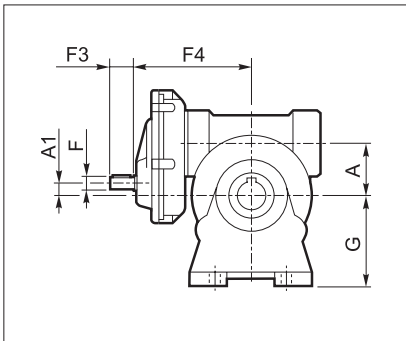

VFR_N..HS

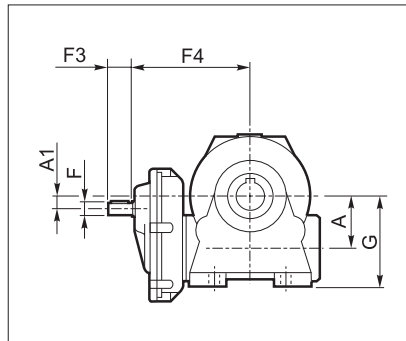

VFR_V..HS

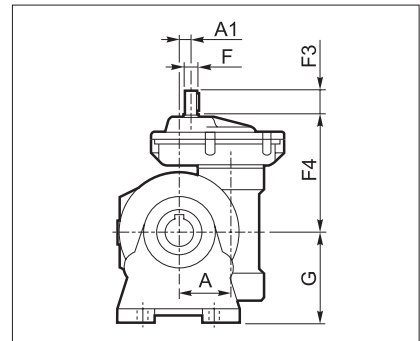

VFR_P..HS

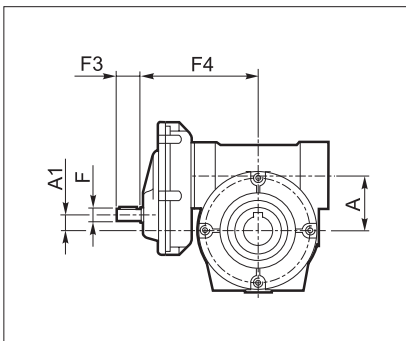

VFR_FA/FC/FR/F..HS

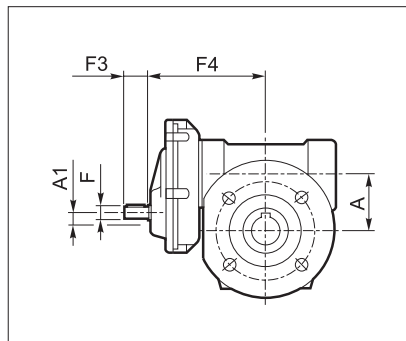

VFR_U..HS

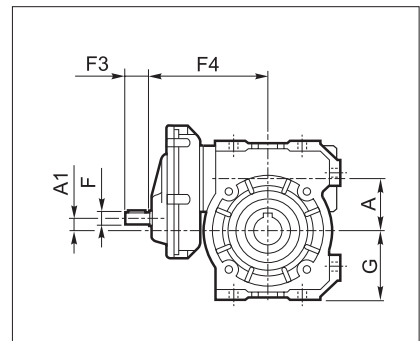

WR_U..HS

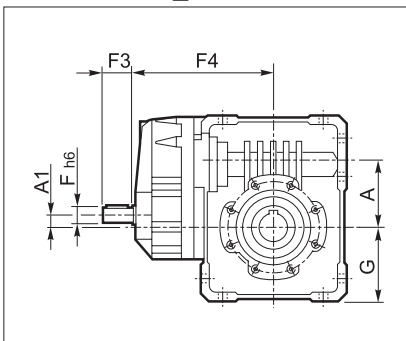

WR_UF/UFC/UFCR..HS

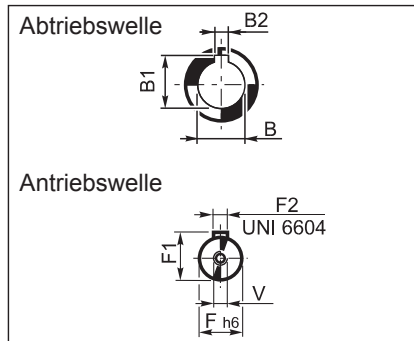
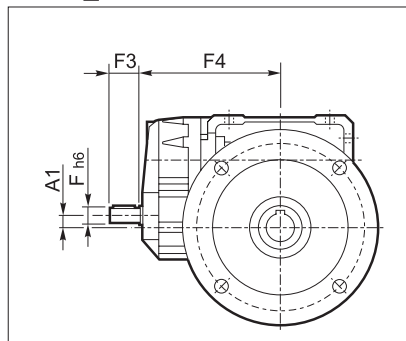

	A	A1	B	B1	B2	F	F1	F2	F3	F4	G	V	
VFR 49_HS	49.5	10	25 H7	28.3	8	11	12.5	4	23	110	82	M4x10	5
VFR 49_U_HS											64.5		
WR 63_HS	62.17	11.42	25 H7	28.3	8	14	16	5	30	138	72.5	M5x12.5	7.1
WR 75_HS	75	11	30(28) H7	33.3(31.3)	8	19	21.5	6	40	162	87	M6x16	11.1
WR 86_HS	86.9	22.9	35 H7	38.3	10	19	21.5	6	40	178	100	M6x16	14.7
WR 110_HS	110.1	21.1	42 H7	45.3	12	24	27	8	50	201	125	M8x19	34
VFR 130_HS	130	45	45 H7	48.8	14	24	27	8	50	228	195	M8x20	57
VFR 150_HS	150	53	50 H7	53.8	14	28	31	8	60	280	220	M8x20	71
VFR 185_HS	185.4	88.4	60 H7	64.4	18	28	31	8	60	310	254	M8x20	110
VFR 210_HS	210	92	90 H7	95.4	25	38	41	10	80	335	335	M10x25	185
VFR 250_HS	250	132	110 G7	116.4	28	38	41	10	80	383	380	M10x25	295

Die mit den anderen Konfigurationen gemeinen Abmessungen sind auf Seiten 116 - 163 angegeben.



VF/VF...HS - VF/W...HS - W/VF...HS

**VF/VF_A..HS
W/VF_A..HS**

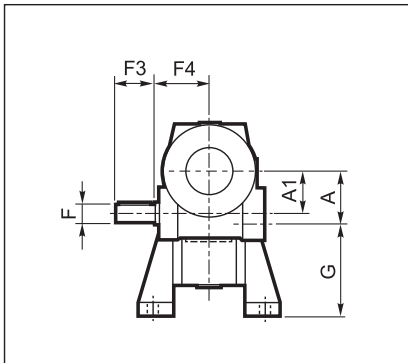

**VF/VF_P..HS
W/VF_P..HS**

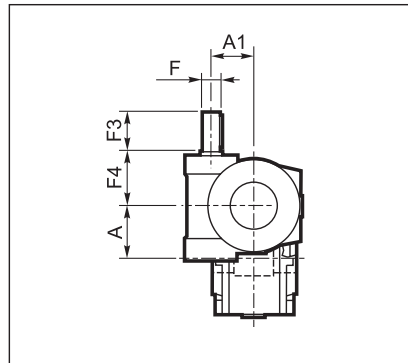

**VF/VF_P..HS
W/VF_P..HS**

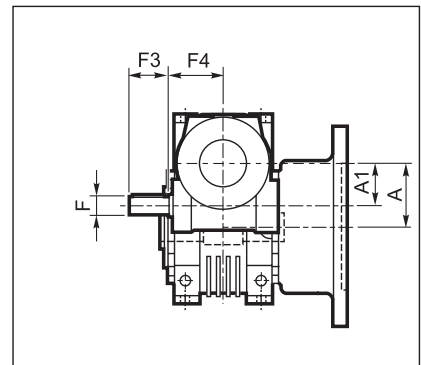
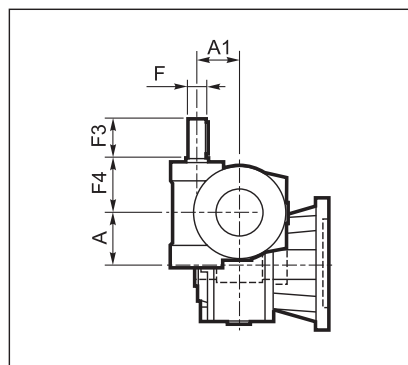
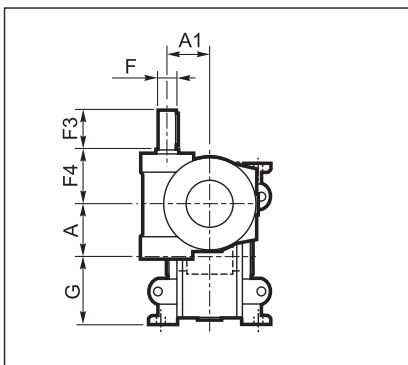
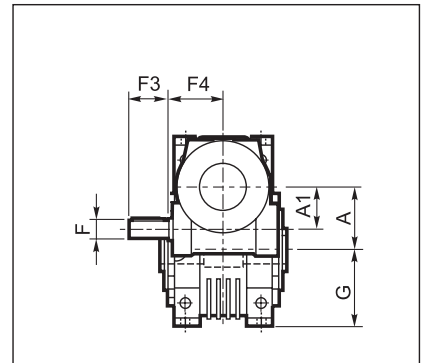

Abtriebswelle

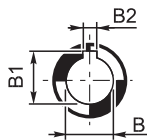

Antriebswelle

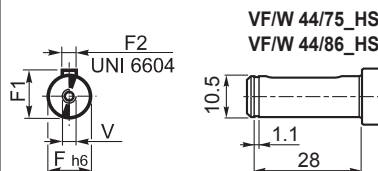

	A	A1	B	B1	B2	F	F1	F2	F3	F4	G	V	Kg
VF/VF 30/44_HS	44.6	30	18 H7	20.8	6	9	10.2	3	20	50	72	—	3.5
VF/VF 30/44_U_HS											55		
VF/VF 30/49_HS	49.5	30	25 H7	28.3	8	9	10.2	3	20	50	82	—	4.5
VF/VF 30/49_U_HS											64.5		
VF/W 30/63_HS	62.17	30	25 H7	28.3	8	9	10.2	3	20	50	100	—	7.5
VF/W 44/75_HS	75	44.6	30 (28) H7	33.3 (31.3)	8	11	12.5	4	30	54	115	—	16.1
VF/W 44/86_HS	86.9	44.6	35 H7	38.3	10	11	12.5	4	30	54	142	—	42
VF/W 49/110_HS	110.0	49.5	42 H7	45.3	12	16	18	5	40	65	170	M6x16	46
W/VF 63/130_HS	130	62.17	45 H7	48.8	14	18	20.5	6	40	110.5	72.5	M6x16	74
W/VF 86/150_HS	150	86.9	50 H7	53.8	14	25	28	8	50	144	100	M8x19	108
W/VF 86/185_HS	185.4	86.9	60 H7	64.4	18	25	28	8	50	144	100	M8x19	109
VF/VF 130/210_HS	210	130	90 H7	95.4	25	30	33	8	60	160	335	M8	225
VF/VF 130/250_HS	250	130	110 G7	116.4	28	30	33	8	60	160	380	M8	325

Die mit den anderen Konfigurationen gemeinen Abmessungen sind auf Seiten 112 - 164 angegeben.



28 ZUBEHÖR

28.1 Ausgangsteckwelle

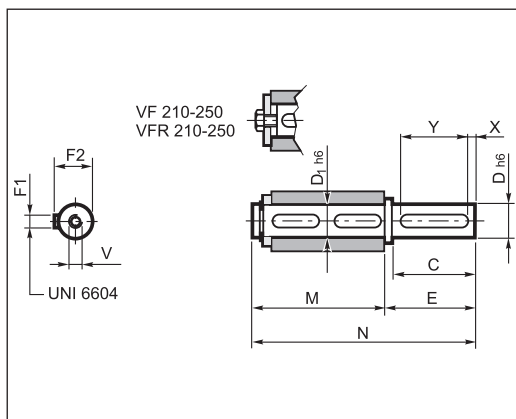

		C	D	D1	E	F1	F2	M	N	V	X	Y
VF	30	30	14	14	35	5	16	61	96	M5x13	5	20
VFR	44	40	18	18	45	6	20.5	70	115	M6x16	5	30
VF/VF	49	60	25	25	65	8	28	89	154	M8x19	5	50
	63	60	25	25	65	8	28	127	192	M8x19	5	50
W	75_D28	60	28	30	65	8	31	134	199	M8x20	5	50
WR	75_D30	60	30	30	65	8	33	134	199	M10x22	5	50
VF/W	86	60	35	35	65	10	38	149	214	M10x22	5	50
	110	75	42	42	80	12	45	164	244	M12x28	7.5	60
	130	80	45	45	85	14	48.5	176	261	M12x32	5	70
VF	150	85	50	50	93	14	53.5	185	278	M16x40	7.5	70
VFR	185	100	60	60	110	18	64	200	310	M16x40	10	80
W/VF	210	130	90	90	140	25	95	255	395	M20x50	5	120
	250	165	110	110	175	28	116	315	490	M24x64	15	140

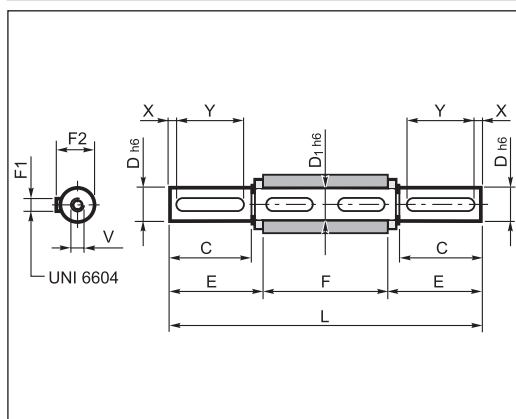

		C	D	D1	E	F	F1	F2	L	V	X	Y
VF	30	30	14	14	32.5	55	5	16	120	M5x13	5	20
VFR	44	40	18	18	42.7	64	6	20.5	149.4	M6x16	5	30
VF/VF	49	60	25	25	63.2	82	8	28	208.4	M8x19	5	50
	63	60	25	25	63.2	120	8	28	246.4	M8x19	5	50
W	75_D28	60	28	30	64	127	8	31	255	M8x20	5	50
WR	75_D30	60	30	30	64	127	8	33	255	M10x22	5	50
VF/W	86	60	35	35	64	140	10	38	268	M10x22	5	50
	110	75	42	42	79.3	155	12	45	313.5	M12x28	7.5	60
	130	80	45	45	84.7	165	14	48.5	334.5	M12x32	5	70
VF	150	85	50	50	90	175	14	53.5	355	M16x40	7.5	70
VFR	185	100	60	60	105	190	18	64	400	M16x40	10	80
W/VF	210	130	90	90	140	260	25	95	540	M20x50	5	120
	250	165	110	110	175	320	28	116	670	M24x64	15	140

28.2 Drehmomentstütze

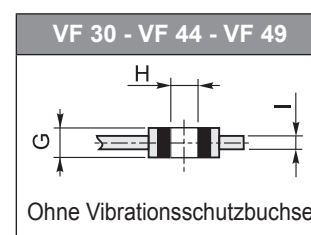
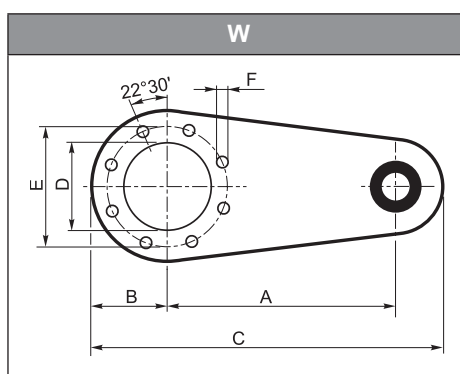
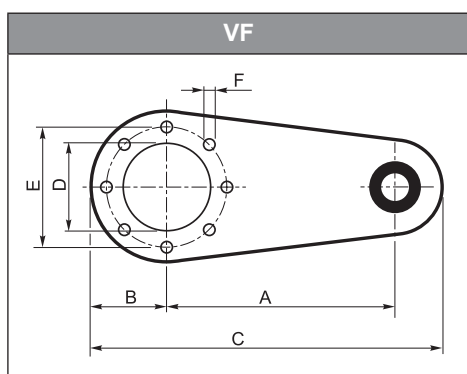

		A	B	C	D	E	F	G	H	I
VF	30	100	40	157.5	50	65	7	14	8	4
VFR	44	100	40	157.5	50	65	7	14	8	4
VF/VF	49	100	55	172.5	68	94	7	14	8	4
	63	150	55	233	75	90	9	20	10	6
W	75	200	63	300	90	110	9	25	20	6
WR	86	200	80	318	110	130	11	25	20	6
VF/W	110	250	100	388	130	165	13	25	20	6
	130	300	125	470	180	215	13	30	25	6
VF	150	300	125	470	180	215	15	30	25	6
VFR	185	350	150	545	230	265	17	30	25	6
W/VF	210	350	175	625	250	300	19	60	50	8
	250	400	225	725	350	400	19	60	50	10



28.3 Satz - Stützfüße

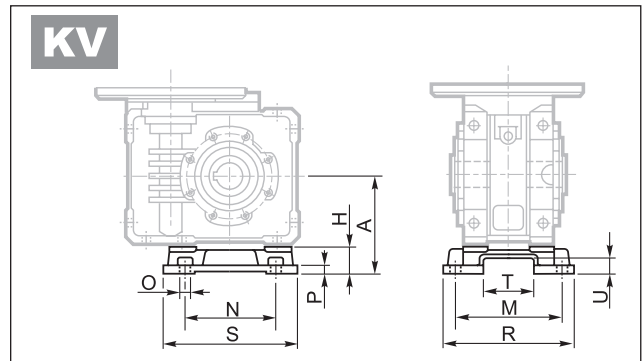
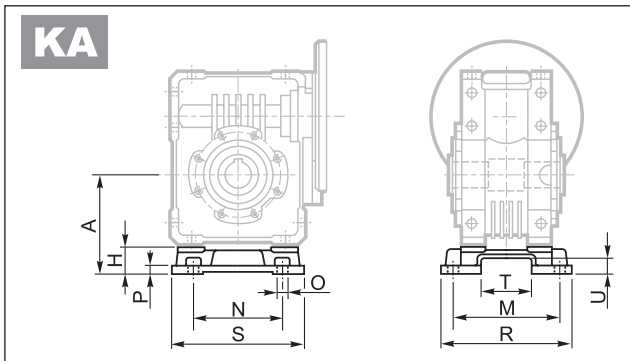

	A	H	M	N	O	P	R	S	T	U
W 63 - WR 63	100	27.5	111	95	11	8	135	145	56.5	15.5
W 75 - WR 75	115	28	115	120	11	9	139	174	56.5	15.5
W 86 - WR 86	142	42	146	140	11	11	170	200	69	20
W 110 - WR 110	170	45	181	200	13	14	210	250	69	20

28.4 Schutzdeckel

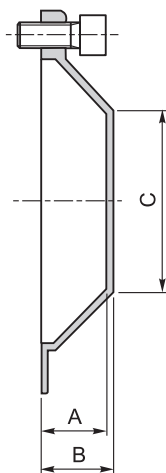

	A	B	C
W 63 - WR 63	26.5	29	Ø35
W 75 - WR 75	24.5	27	Ø54
W 86 - WR 86	26.5	29	Ø71
W 110 - WR110	27.5	30	Ø89



29 KUNDENSEITIGE WELLEN

Für die mit dem Getriebe verbundene Antriebswelle, wird empfohlen, hochwertigen Stahl zu verwenden und die im folgenden Schema enthaltenen Abmessungen zu beachten.

Darüber hinaus sollte der Einbau mit einer axialen Sperrvorrichtung der Welle vervollständigt werden, siehe folgendes Beispiel, hierbei die einzelnen Komponenten in Abhängigkeit der verschiedenen Anforderungserfordernisse überprüfen und dimensionieren.

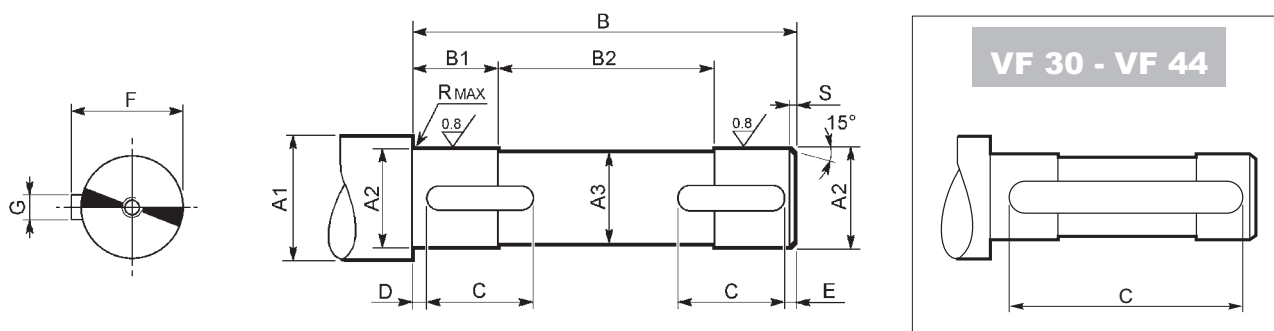

	A1	A2	A3	B	B1	B2	C	D	E	F	G	R	S	 UNI 6604
VF 30	≥ 19	14 f7	13	53	18.5	16	40	6.5	6.5	16	5 h9	0.5	1.5	5x5x40 A
VF 44	≥ 23	18 f7	17	62	22.5	17	50	6	6	20.5	6 h9	0.5	1.5	6x6x50 A
VF 49	≥ 30	25 f7	24	80	20.5	39	20	2	2	28	8 h9	1	1.5	8x7x20 A
W 63	≥ 30	25 f7	24	118	38	42	35	2	2	28	8 h9	1	1.5	8x7x35 A
W 75	≥ 35	28 f7	27	125	38	49	40	2	2	31	8 h9	1	1.5	8x7x40 A
	≥ 35	30 f7	29	125	38	49	40	2	2	33	8 h9	1	1.5	8x7x40 A
W 86	≥ 42	35 f7	34	138	43	52	40	2	2	38	10 h9	1.5	1.5	10x8x40 A
W 110	≥ 48	42 f7	41	153	43	67	50	2	2	45	12 h9	1.5	2	12x8x50 A
VF 130	≥ 52	45 f7	44	163	50.5	62	60	2.5	2.5	49.5	14 h9	2.5	2	14x9x60 A
VF 150	≥ 57	50 f7	49	173	53	67	70	2.5	2.5	53.5	14 h9	2.5	2	14x9x70 A
VF 185	≥ 68	60 f7	59	188	63	62	80	2.5	2.5	64	18 h9	2.5	2	18x11x80 A
VF 210	≥ 99	90 f7	89	258	83	92	80	3	3	95	25 h9	2.5	2.5	25x14x80 A
VF 250	≥ 121	110 h7	109	318	83	152	80	3	3	116	28 h9	2.5	2.5	28x16x80 A



30 RUTSCHKUPPLUNG

30.1 Beschreibung

Die Rutschkupplung, die für Schneckengetriebe **VF44 - VF49** und **W63...W110**, entwickelt wurde, dient dem Schutz des Getriebes vor zufälligen Überlastungen, welche die Antriebselemente zerstören könnten.

Bezüglich traditioneller Rutschkupplungen, welche extern an das Getriebe angeschlossen werden, bietet diese Lösung folgende Vorteile:

- gleiche Aussen-Abmessungen des Getriebes wie das Standard gehäuse
- wartungsfrei, da das System in Ölbad arbeitet
- das maximal übertragbare Moment kann einfach, per Hand, von aussen eingestellt werden
- ständiges Rutschen verursacht keinen Schaden, da die mechanischen Teile im Ölbad laufen.



Von einer Montage in Hebemechanismen wird abgeraten.

30.2 Funktionsweise

Die Rutschkupplung arbeitet wie eine doppelkonische Reibfläche, die direkt auf einen aus Sphäroguss bestehenden Innenring GS 400/12 des Bronze- schneckenrades wirkt.

Die axiale Anpresskraft, die die konischen Reibflächen zusammendrückt, wird von Tellerfedern erzeugt.

Die Einstellung des Rutsch- momentes kann in einer einfachen Weise durch Drehen einer Verstellmutter, ausserhalb des Getriebes, erreicht werden.

30.3 Schutz der Arbeitsma- schine vor Überlastungen:

Die Rutschkupplung ist eingestellt auf das notwendige Moment der Arbeitsmaschine und schützt alle mechanischen Teile der Übertragungseinheit. Weiter vermeidet sie Beschädigungen hervorgerufenen durch mögliche Überlastungen.

30.4 Auskuppeln bei Selbsthemmung

In einigen Anwendungsfällen ist es nötig die Ausgangswelle des Getriebes zu drehen während die Arbeitsmaschine steht: Dies ist bei einem normalen Schneckengetriebe nicht möglich. Die Verwendung der Rutschkupplung macht es möglich, wenn vorher die Verstellmutter gelöst wird.



30.5 VF...L, W...L

L1								L2								
	N	A	V	U	F1 FC1 FR1 FA1	F2 FC2 FR2 FA2**	P1 P2		N	A	V	U	F1 FC1 FR1 FA1**	F2 FC2 FR2 FA2	P1 P2	
VF VF/VF*									VF VF/VF*							
	U	UF1 UFC1	UF2 UFC2	UFCR1	UFCR2				U	UF1 UFC1	UF2 UFC2	UFCR1	UFCR2			
W VF/W*									W VF/W*							

* In den Doppelschneckengetrieben Typ VF/VF ist das Drehmomentstutz auf das 2te Getriebe für die Ausführungen L1 oder L2 installiert; es ist auf das 1te Getriebe für Ausführung LF installiert.

LF				
	VF/W	44/75	44/86	49/110
	W/VF	63/130	86/150	86/185

Wenn nicht anders angegeben, werden die Getriebe VF...L geliefert mit der Verstellmutter links (L1), mit Sicht auf den E-Motor.

30.6 Abmessungen

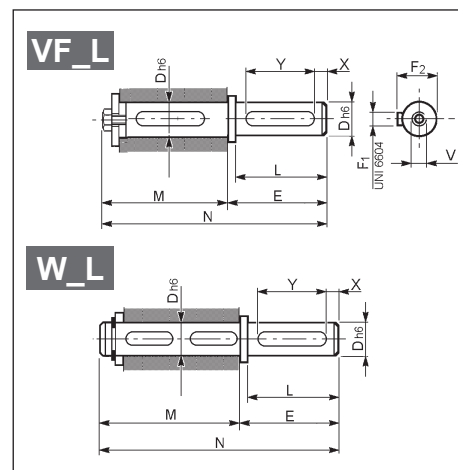
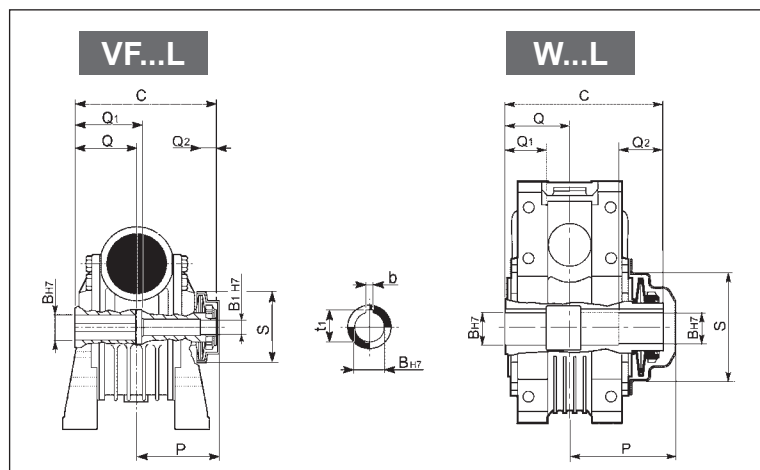

	Rutschkupplung										Ein freies Wellenende									
	C	Q	Q1	Q2	P	S	B _{H7}	B _{1H7}	t ₁	b	L	D _{h6}	E	F1	F2	M	N	V	X	Y
VF 44L	79	32	32	12	48	42.5	18	11	20.8	6	40	18	45	6	20.5	86	131	M6x16	5	30
VF 49L	105	41	51	15	63.5	66.5	25	14	28.3	8	60	25	65	8	28	114.5	179.5	M8x19	5	40
W 63L	145	60	40	40	100	77	25	-	28.3	8	60	25	65	8	28	152	217	M8x19	5	50
W 75L_D30	154.5	63.5	40	40	104	100	30	-	33.3	8	60	30	65	8	33	161.5	226.5	M10x22	5	50
W 86L	170	70	50	45	113	119	35	-	38.3	10	60	35	65	10	38	179	244	M10x22	5	50
W 110L	191	77.5	55	45	133	134	42	-	45.3	12	75	42	80	12	45	200	280	M12x28	7.5	60



30.7 Rutschmomenteinstellung

Eine Voreinstellung des Rutschmoments wird im Werk durchgeführt.

Das voreingestellte Moment entspricht dem im Katalog angegebenen Nennmoment Mn_2 [$n_1=1400$] des Getriebes Typ VF oder W.

Nachfolgend werden die im Werk durchgeführten Arbeiten zur Einstellung des Rutschmoments beschrieben.

Die gleichen Schritte, mit Ausnahme des Schrittes Nr. 2, müssen wiederholt werden, wenn ein anderer Momentwert benötigt wird.

1. Die Verstellmutter so weit anziehen, daß sich die Tellerfedern nicht mehr von Hand drehen lassen.
2. Es werden 2 Bezugsmarkierungen unter dem gleichen Winkel sowohl auf der Verstellmutter als auch auf der Hohlwelle angebracht.
Die hiermit gekennzeichnete Stellung ist der Ausgangspunkt für jede weitere Rutschmomenteinstellung durch die Verdrehung der Verstellmutter.
3. Die Verstellmutter wird soweit angezogen, bis das gewünschte Nennmoment Mn_2 des Getriebes erreicht ist. Sollte ein anderes Rutschmoment erforderlich sein, ist gemäß folgendem Diagramm (ausgehend von Punkt 2.) die Verstellmutter um den angegebenen Wert gegenüber der Hohlwelle zu drehen ($\frac{1}{4}$ bis 2 Umdrehungen).

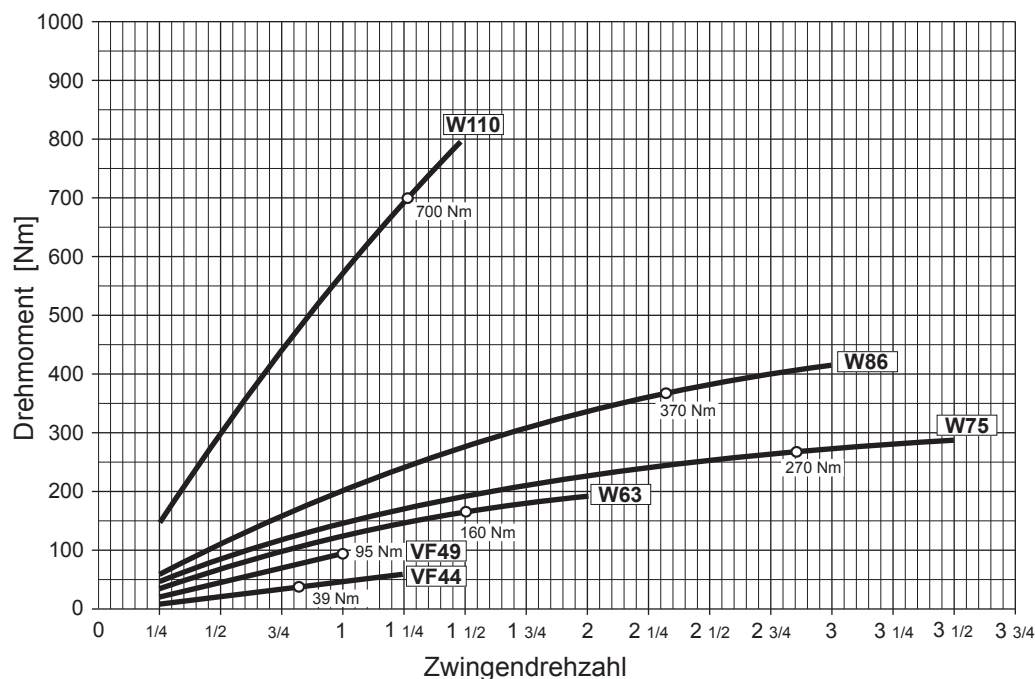

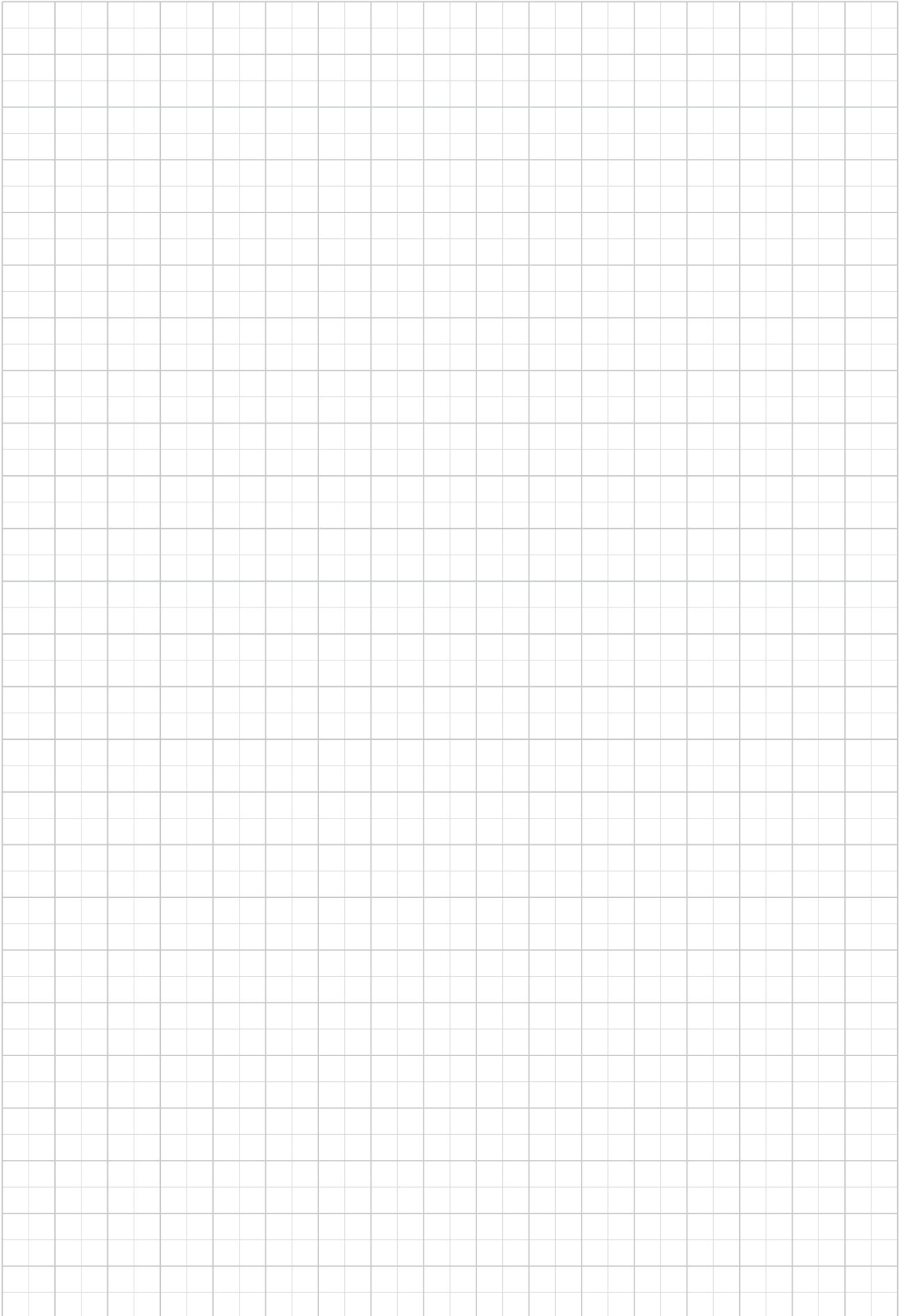
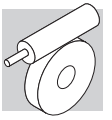



VF-EP / W-EP - GETRIEBE FÜR RAUE UMGEBUNGEN

31 DIE VORTEILE DER EP-VERSION FÜR DIE NAHRUNGSMITTELINDUSTRIE

Den Getränke- und Nahrungsmittelindustrien steht heute eine Reihe an Getriebemotoren zur Verfügung, die ausdrücklich für deren spezifische Anforderungen geeignet ist und deren Merkmale in den üblichen Serienproduktionen nicht zu finden sind.

Der vollständig hermetische Verschluss der Getriebe und das einfach mögliche hygienische Reinigen seiner Flächen, erlauben ihre Installation auch in der Nähe von Bearbeitungsprozessen ohne dass dafür weitere Abschirmungen oder Verkleidungen erforderlich sind. Das an den Außenflächen aufgetragene Epoxid- Schutzsystem mit seiner Stärke von circa 200 µm gewährleistet darüber hinaus einen hervorragenden Reibungswiderstand.

Die komplette Einheit, Getriebemotor oder nur das Getriebe, werden mit einem 2K Epoxid-Lack grundiert und anschließend mit einem sehr widerstandsfähigen 2K Epoxid-Lack, der blei- und chromfrei ist, lackiert. Der Lack besitzt NSF und FDA Zulassungen für den lebensmittelverarbeitenden und den pharmazeutischen Bereich für gelegentliche Berührungen. Weiterhin ist er in Bezug auf die Meisten Säuren und alkalischen Substanzen sehr widerstandsfähig. Gegen eine Vielzahl von chemischen Reinigungsmitteln, die häufig in der Industrie eingesetzt werden, weist er zusätzlich eine gute Beständigkeit auf. Im Sinne der Norm ISO 9223 erweist sich das angewendete Lackiersystem auch für die aggressivsten bzw. in die Klasse C5 einstuftbaren Umgebungen als geeignet.

In drei verschiedenen Farben verfügbar, die den RAL-Farben 9010 (Weiß), 5010 (Blau) und 9006 (Hellgrau metallic) entsprechen.

Das Produkt der Serie **EP** kann durch den Einsatz der zahlreichen Optionen und des Montagezubehörs in angemessener Weise konfiguriert bzw. weiter ausgebaut werden.

Getriebegrößen: 44 (ausgenommen VFR), 49, 63, 75, 86. Verfügbare Antriebssysteme: von 0,12 bis 4 KW, sowohl in Kompaktausführung als auch im IEC- Standard - 2-, 4- und 6-polig.

Ideal für die Industrie der Nahrungsmittelverarbeitung



Widerstandsfähig gegen Korrosion

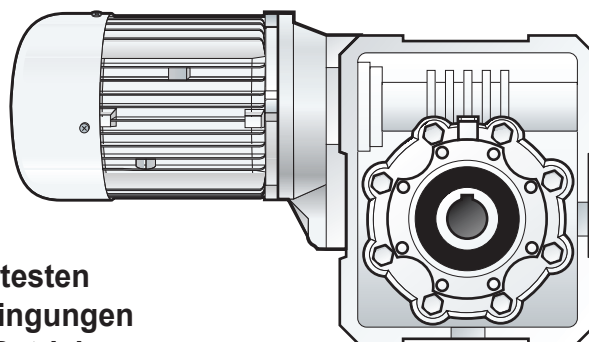

Auch für die härtesten Umgebungsbedingungen angemessener Betrieb

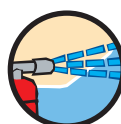

Unter Anwendung der am häufigsten verwendeten Reinigungsmitteln waschbar/hygienisch säuberungsfähig.

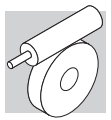

AUSSTATTUNG DER GETRIEBE

- ① Das Getriebe ist vollkommen versiegelt, um so jegliche eventuelle Verschmutzung der Umgebung zu reduzieren.
- ② Hohle Abtriebswelle in rostfreiem Stahl AISI 316.
- ③ Identifikationsschild und Schrauben in Edelstahl.
- ④ Bohrungen für die Wasserdrainage - verhindern eine Wasseransammlung nach einer Wäsche.
- ⑤ Als Option für das normale Schmiermittel ist synthetisches Öl der Klasse UH1 verfügbar, dass im Fall eines zufälligen Kontakt auch nahrungsmittelverträglich ist.

- ⑥ Dichtringe mit innerer Feder aus Edelstahl. Verfügbarkeit von PTFE-Dichtungen mit Abschirmung in Edelstahl, widerstandsfähig gegen Druck.
- ⑦ Aussenflächen sind mit einem 2K Epoxid-Lack grundiert und lackiert, der eine FDA und eine NSF Zulassung (in Abhängigkeit von der Farbauswahl) für gelegentliche Berührungen mit Lebensmittel hat.
- ⑧ Verschluss der nicht verwendeten Gewindebohrungen mit Eindrückstößeln.

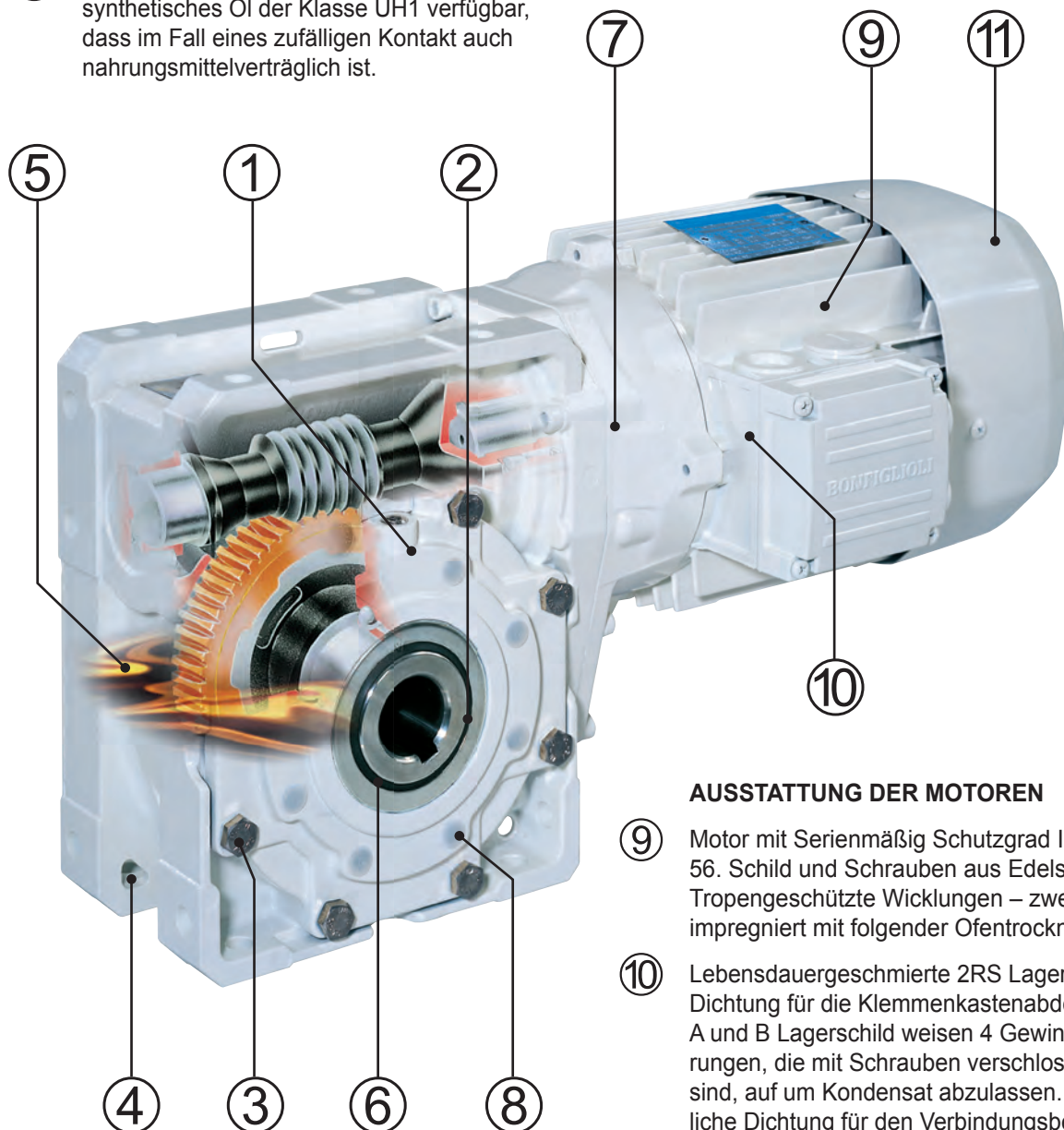

AUSSTATTUNG DER MOTOREN

- ⑨ Motor mit Serienmäßig Schutzgrad IP 56. Schild und Schrauben aus Edelstahl. Tropengeschützte Wicklungen – zweifach impregniert mit folgender Ofentrocknung.
- ⑩ Lebensdauer geschmierte 2RS Lager. NBR-Dichtung für die Klemmenkastenabdeckung. A und B Lagerschild weisen 4 Gewindebohrungen, die mit Schrauben verschlossen sind, auf um Kondensat abzulassen. Zusätzliche Dichtung für den Verbindungsbereich zwischen Motor und Getriebe.
- ⑪ Kühlflüterradd in Polyamid-Material, nahrungsmittelverträglich.



GETRIEBE

W-EP — 63 U 30 P90 B14 B3 RAL9010 ...

OPTIONEN

LACKIERUNG

NP unlackiert	
RAL9010	
RAL5010	
RAL9006 (keine Konformität mit FDA und NSF)	

EINBAULAGEN

VF-EP 44 VF-EP 49	B3
W-EP 63 W-EP 75 W-EP 86	B3 (default), B6, B7, B8, V5, V6

MOTOR BAUFORM
B5, B14 (IEC standard)

BEZEICHNUNG DER ANTRIEBSSEITE

	VF-EP	VF-EP R	W-EP	W-EP R
P(IEC)	 P63...P80	 P63	 P71...P112	 P63...P90
s_			 S1...S3	

ÜBERSETZUNG

BAUFORM

GETRIEBEBAUGRÖSSE

VF-EP: **44, 49**

W-EP: **63, 75, 86**

— (blank)
R (Vorstufe VF-EP 44)

GETRIEBE TYP

VF-EP

W-EP

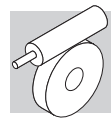





MOTOR

BE-EP 80B 4 B14 230/400-50 CLF RAL9010

OPTIONEN

LACKIERUNG

NP unlackiert	
RAL9010	
RAL5010	
RAL9006 (keine Konformität mit FDA und NSF)	

KLEMMKASTENLAGE
W (default), **N**, **E**, **S**

ISOLIERUNGSKLASSE
CL F Standard
CL H Option

SPANNUNG - FREQUENZ

BAUFORM
— (Kompaktmotor)
B5, B14 (motore IEC)

POLZAHL
2, 4, 6,

MOTOR-BAUGRÖSSE
1SC ... 3LC (Kompaktmotor)
63 ... 112 (IEC - Motor)

MOTORTYP

M-EP = Dreiphasen Kompaktmotor
BN-EP = Dreiphasen IEC Motor

ME-EP = Dreiphasen Kompaktmotor, Klasse IE2
BE-EP = Dreiphasen IEC Motor, Klasse IE2



33 GETRIEBE OPTIONEN

PX

Option Dichtringe an der Abtriebswelle. Die speziellen, als Option angebotenen Dichtringe erweitern die Applikationsmöglichkeiten der Getriebe auch auf solche Prozesse, in denen häufig mit Wasserdruckstrahlern gewaschen wird. Die externe Abschirmung in EDELSTAHL und die Realisierung mit doppelter Dichtlippe steuern zur Grundfunktionalität noch die Widerstandsfähigkeit gegen den Umgebungsdruck bei, während das besondere, dafür verwendete Material (PTFE) einen hervorragenden Widerstand gegen aggressiv wirkende chemische Elemente, einen niedrigen Reibungskoeffizienten und lange Lebensdauer garantiert.

PV

Dichtringe in Fluor-Elastomer an der Abtriebswelle. Innere Feder in Edelstahl.

UH1

Option nahrungsmittelverträgliche Öle. The gearbox is factory filled with "long life" lubricant, approved for incidental food contact and registered as UH1 by the NSF for the food and pharma industry, it also satisfy the FDA 21 CFR Sec. 178.3570 norms. Seine synthetische Herkunft auf Poliglykol-Basis erweitert nicht nur den Einsatz auf einen breiter angelegten Temperaturbereich (-25° C bis auf + 150° C) sondern macht es möglich, dass hier ein regelmäßiger Austausch nicht mehr erforderlich ist und daher sich die Schmiermittelfüllung, in Abwesenheit von verschmutzenden Stoffen, als auf „Lebenszeit“ versteht.

NACHWEISE

AC - Konformitätsbescheinigung Dokument mit dessen Ausstellung die Konformität des Produkts mit dem Auftrag, und dessen Konstruktion in Konformität mit den vom Qualitätsmanagementsystem von Bonfiglioli Riduttori vorgesehenen Standardfertigungs- und -kontrollverfahren bescheinigt wird.

CC – Prüfzeugnis

Die Bestellung führt zur Durchführung von Kontrollen der Konformität mit dem Auftrag, allgemeinen Sichtkontrollen und instrumentalen Prüfungen der Passmaße. Des Weiteren werden allgemeine Betriebskontrollen bei Leerlauf sowie Prüfungen der Funktionalität der Dichtungen bei Stillstand und während des Betriebs durchgeführt. Die Prüfung wird anhand einer Stichprobe des Versandloses durchgeführt.

34 OPTIONEN MOTOREN

Die verfügbaren Optionen für die Motoren BN-EP, BE-EP, M-EP und ME-EP sind: D3, E3, K1, H1, NH1, RC, RV, ACM, CC, CUS, S2, S3, S9.

Detaillierte Informationen entnehmen Sie bitte dem Kapitel "Elektromotoren".

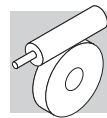

35 WEITERE INFORMATIONEN ÜBER GETRIEBE UND GETRIEBEMOTOREN

Einbaulagen, technische Daten, Motorverfügbarkeiten, Trägheitsmomente und Abmessungen für die **VF-EP** und **W-EP** Serie unterscheiden sich nicht von der Standard-Serie **W** und **VF**. Genauso verhält es sich mit den technischen Daten von **ME-EP**, **M-EP** und **BE-EP**, **BN-EP** Motoren im Vergleich zu den **ME**, **M**, **BE** und **BN** Motoren. Alle Informationen sind in den entsprechenden Kapitel des Kataloges zu finden.

36 ZUBEHÖR DER SERIE EP

Für das Getriebe kann, dem entsprechenden Einsatz gemäß, bestimmtes Zubehör angefordert werden, dass die Architektur des Produkts vervollständigt. Dabei handelt es sich insbesondere um:

- Abtriebswelle, sowohl einfach als zweiseitig, aus EDELSTAHL, Typ 316, komplett mit Keilen aus dem gleichen Material.
- Reaktionsarm aus lackiertem Blech (gewünschte RAL_ angeben).
- Sicherheitsabdeckung aus Kunststoff für den Bereich der (hohlen) Abtriebswelle (W63,W75 und W86) oder aus gummibeschichtetem Blech NBR (VF 44,VF 49) mit Schrauben aus EDELSTAHL und einem Schutzgrad von insgesamt IP56.

36.1 Ausgangsteckwelle

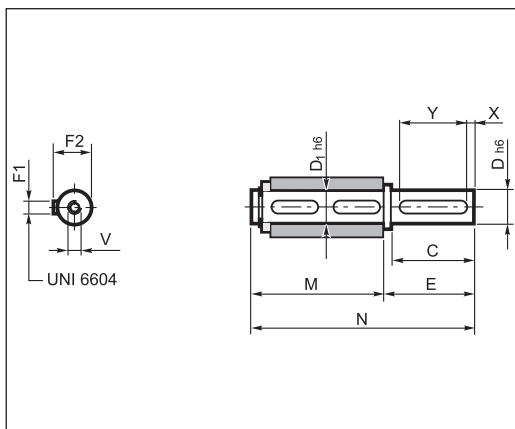

	C	D	D1	E	F1	F2	M	N	V	X	Y
VF-EP 44	40	18	18	45	6	20.5	70	115	M6x16	5	30
VF-EP 49 VF-EP R 49	60	25	25	65	8	28	89	154	M8x19	5	50
W-EP 63 W-EP R 63	60	25	25	65	8	28	127	192	M8x19	5	50
W-EP 75 W-EP R 75	60	30	30	65	8	33	134	199	M10x22	5	50
W-EP 86 W-EP R 86	60	35	35	65	10	38	149	214	M10x22	5	50

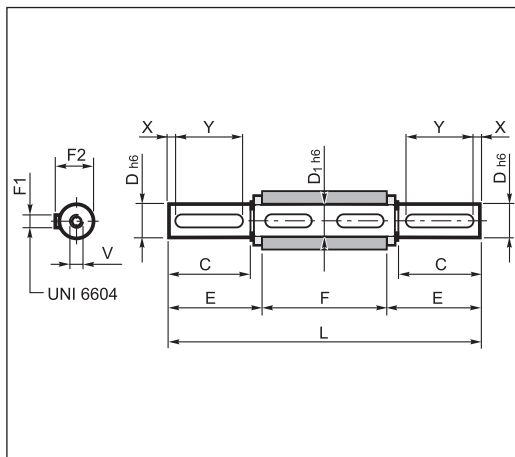

	C	D	D1	E	F	F1	F2	L	V	X	Y
VF-EP 44	40	18	18	42.7	64	6	20.5	149.4	M6x16	5	30
VF-EP 49 VF-EP R 49	60	25	25	63.2	82	8	28	208.4	M8x19	5	50
W-EP 63 W-EP R 63	60	25	25	63.2	120	8	28	246.4	M8x19	5	50
W-EP 75 W-EP R 75	60	30	30	64	127	8	33	255	M10x22	5	50
W-EP 86 W-EP R 86	60	35	35	64	140	10	38	268	M10x22	5	50



36.2 Drehmomentstütze

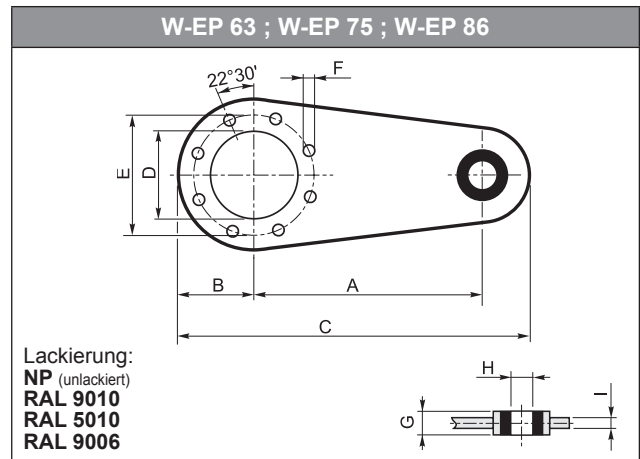
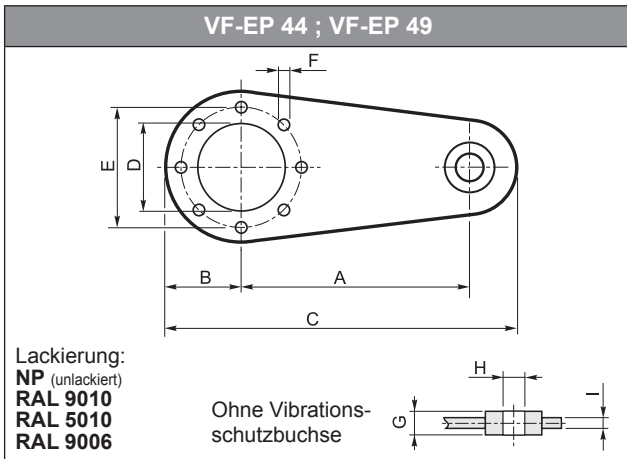

	A	B	C	D	E	F	G	H	I
VF-EP 44	100	40	157.5	50	65	7	14	8	4
VF-EP 49 VF-EP R 49	100	55	172.5	68	94	7	14	8	4
W-EP 63 W-EP R 63	150	55	233	75	90	9	20	10	6
W-EP 75 W-EP R 75	200	63	300	90	110	9	25	20	6
W-EP 86 W-EP R 86	200	80	318	110	130	11	25	20	6

36.3 Schutzdeckel

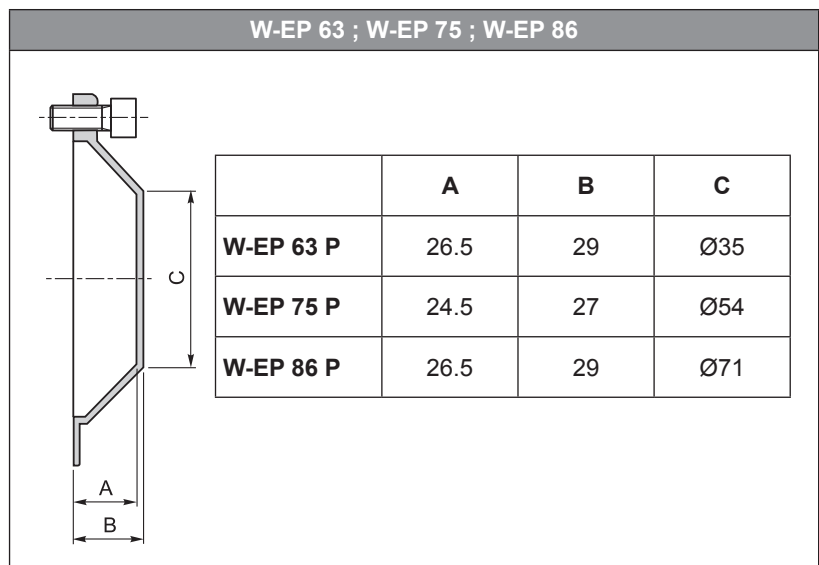
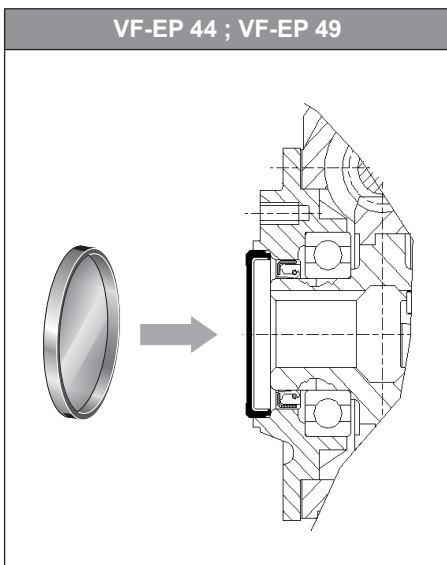

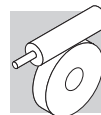

ENDSCHALTER-VORRICHTUNG RVS

37 ALLGEMEINE INFORMATIONEN

Die Endschalter-Vorrichtung Typ RVS wurde entwickelt, um die Getriebemotoren mit Schnecke von Bonfiglioli Riduttori bei der Betätigung von:

- Fenstern und Vorrichtungen zur Schattenerzeugung für Treibhäuser
- automatischen Toren
- Klappfenstern
- Dosieranlagen für Getreide im Zootechnik-Sektor
- Drosselventilen zu vervollständigen und an diese anzupassen.

Die mit der Vorrichtung RVS ausgestatteten Getriebemotoren sind auch für alle anderen Schritt-Anwendungen geeignet, bei denen eine kontrollierte und genaue Bewegung erforderlich ist.

Für die oben beschriebenen Anwendungen, die durch einen leichten Schritt-Service charakterisiert sind, empfiehlt es sich, die Wahl der Übertragungsgruppen ausschließlich, wie auf den Seiten des Paragraphen 40 angegeben, durchzuführen. Die so durchgeführten Wahlen sind konform zu dem bestimmten Servicetyp und zu den Höchstgeschwindigkeiten, die mit dem regulären Betrieb der Endschalter-Vorrichtung verträglich sind.

Die vollständige Konfiguration wird durch die Montage der Endschalter-Vorrichtung auf das entsprechende Motorgetriebe mittels des spezifischen (auch für die Gruppen Typ VF 49, W63, W75 und W86 verfügbaren), auf der folgenden Seite gezeigten Montage-Sets erhalten.

Für die Montage der Vorrichtung **RVS** müssen die Getriebemotoren in der geflanschten Herstellungsform sein.

37.1 Technische eigenschaften

Der Betrieb der Endschalter-Vorrichtung gründet auf einer Differentialbewegung von zwei mit Nocken ausgestatteten Räderpaaren und auf die entsprechende Betätigung der Präzisions-Mikroschalter, die durch Relais (vom Installateur eingebaut) den Bewegungsstopp und die Bewegungsumkehr steuern. Die Extrem-Positionen der Bewegung, die Öffnung und das Schließen des Rahmens, können leicht mit dem bereits installierten Getriebemotor und ohne Verwendung von spezifischen Ausrüstungen, sondern nur mit einem herkömmlichen Inbusschlüssel eingestellt werden.

Ist die gewünschte Einstellung erreicht und fixiert, wird diese in der Zeit konstant gehalten, wodurch die Betätigungen oft wiederholt werden können. In der Grundausführung wird die Endschalter-Gruppe **RVS** mit einem innen vorverkabelten und ungefähr ein Meter langen Kabelpaar geliefert.

Die Gruppe ist außerdem in folgenden Varianten erhältlich:

RVS ME: ist mit einem äußeren Klemmenkasten mit sechs End-verschlüssen ausgestattet, an die die Verbindungskabel mit den Relais angeschlossen werden.

RVS DM: ist mit einer doppelten, serienverbundenen Mikroschalter-Serie für eine vollkommene Eingriffssicherheit und entsprechend der Normen ausgestattet, die die Redundanz dieser Vorrichtung vorsehen.







RVS ME DM: mit einer äußeren und doppelten Mikroschalter-Serie, wie oben beschrieben, ausgestattete Vorrichtung.

Alle Varianten der Endschalter-Vorrichtungen sind wie folgt charakterisiert:

- äußerst leise
- gemäßiger Raumbedarf
- leicht zu installieren und einzustellen
- mit Gesamtschutz IP55 ausgestattet
- innerhalb eines Höchstbereichs von 43 Umdrehungen der Abtriebswelle einstellbar





38 ART.-NR. FÜR DIE BESTELLUNG

Die für die Anwendung notwendige Vorrichtung oder ihre Variante bestimmen und dabei auf die unterstehende Tabelle für die entsprechende Art.-Nr. für die Bestellung Bezug nehmen.

RVS	RVS ME	RVS DM	RVS ME DM
			
cod. 193312025	cod. 193312026	cod. 193312027	cod. 193312028

Außerdem die entsprechende Art.-Nr. des Konfigurations-Sets für das Getriebe auswählen, auf das die Endschalter-Vorrichtung installiert werden soll.

			
cod. 192860001	cod. 192860002	cod. 192860003	cod. 192860004

			
VF 49 F - VFR 49 F	W 63 UFC - WR 63 UFC	W 75 UFC - WR 75 UFC	W 86 UFC - WR 86 UFC

39 BEZEICHNUNG

Einsatz der **VF** und **W** für Passung an Anlaufvorrichtung.

W R 75 UFC1 D30 240 P71 B5 B3

OPTIONEN
EINBAULAGEN
B3 (default), **B6, B7, B8, V5, V6**

MOTORFLANSCH IEC
B5
B14

BEZEICHNUNG DER ANTRIEBSSEITE
VF: **P** (IEC)
W: **S_, P** (IEC)

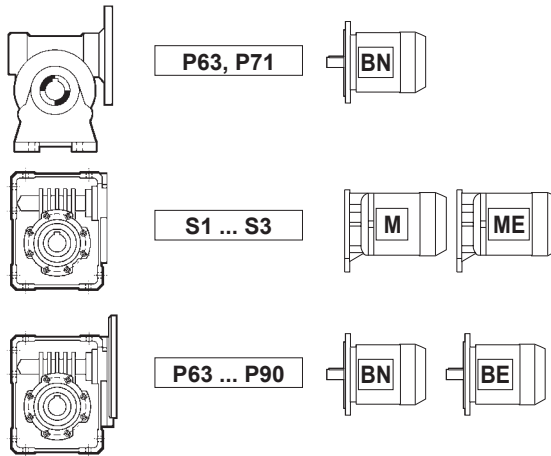

ÜBERSETZUNG

ABTRIEBSWELLEDURCHMESSER
D30 (nur für W75)

BAUFORM
VF: **F**
W: **UFC**

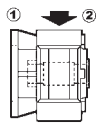

F (1, 2)

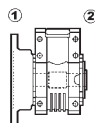

UFC (1, 2)

BAUGRÖSSE
VF: **49**
W: **63, 75, 86**

VORSTUFE

R

GETRIEBE TYP

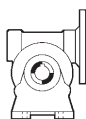

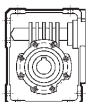

VF



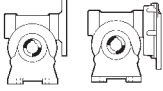

W

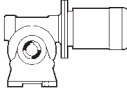

**40 GETRIEBEMOTOREN-AUSWAHLTABELLEN****0.12 kW**

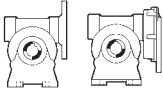
n_2 min ⁻¹	M_2 Nm	i	 IE1	 IEC	 IE1
4.7	98	300	VFR 49_300	P63	BN63A4
5.8	89	240	VFR 49_240	P63	BN63A4
6.7	83	210	VFR 49_210	P63	BN63A4
7.8	76	180	VFR 49_180	P63	BN63A4
10.4	64	135	VFR 49_135	P63	BN63A4
14.0	41	100	VF 49_100	P63	BN63A4
17.5	37	80	VF 49_80	P63	BN63A4
20.0	34	70	VF 49_70	P63	BN63A4
23.3	31	60	VF 49_60	P63	BN63A4

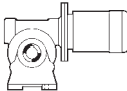

0.18 kW

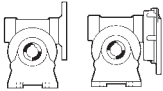
n_2 min ⁻¹	M_2 Nm	i	 IE1	 IEC	 IE1
7.8	112	180	VFR 49_180	P63	BN63B4
10.4	95	135	VFR 49_135	P63	BN63B4
14.0	61	100	VF 49_100	P63	BN63B4
17.5	54	80	VF 49_80	P63	BN63B4
20.0	49	70	VF 49_70	P63	BN63B4
23.3	45	60	VF 49_60	P63	BN63B4

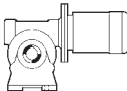

0.25 kW

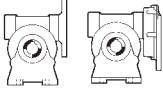
n_2 min ⁻¹	M_2 Nm	i	 IE1	 IEC	 IE1
4.7	214	300	WR 63_300	P71	BN71A4
5.8	192	240	WR 63_240	P71	BN71A4
7.3	170	192	WR 63_192	P71	BN71A4
10.4	136	135	WR 63_135	P71	BN71A4
12.3	121	114	WR 63_114	P71	BN71A4
14.0	82	100	VF 49_100	P71	BN71A4
17.5	72	80	VF 49_80	P71	BN71A4
20.0	66	70	VF 49_70	P71	BN71A4
23.3	61	60	VF 49_60	P71	BN71A4

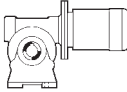

0.37 kW

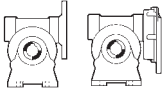
n_2 min ⁻¹	M_2 Nm	i	 	IEC 		
				IE1	IE1	
4.7	382	300	WR 86_300	P71	BN71B4	
5.8	306	240	WR 75_240	P71	BN71B4	
7.3	290	192	WR 86_192	P71	BN71B4	
7.8	257	180	WR 75_180	P71	BN71B4	
9.3	226	150	WR 75_150	P71	BN71B4	
10.4	204	135	WR 63_135	P71	BN71B4	
12.3	181	114	WR 63_114	P71	BN71B4	
14.0	133	100	W 63_100	P71	BN71B4	W 63_100 S1 M1SD4
17.5	108	80	VF 49_80	P71	BN71B4	
20.0	98.3	70	VF 49_70	P71	BN71B4	
23.3	90.5	60	VF 49_60	P71	BN71B4	

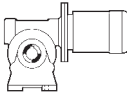
0.55 kW

n_2 min ⁻¹	M_2 Nm	i	 	IEC 		
				IE1	IE1	
4.7	559	300	WR 86_300	P80	BN80A4	
5.8	483	240	WR 86_240	P80	BN80A4	
7.3	423	192	WR 86_192	P80	BN80A4	
7.8	376	180	WR 75_180	P80	BN80A4	
8.3	383	168	WR 86_168	P80	BN80A4	
9.3	331	150	WR 75_150	P80	BN80A4	
10.1	330	138	WR 86_138	P80	BN80A4	
11.7	287	120	WR 75_120	P80	BN80A4	
14.0	194	100	W 63_100	P80	BN80A4	W 63_100 S1 M1LA4
17.5	170	80	W 63_80	P80	BN80A4	W 63_80 S1 M1LA4
21.9	148	64	W 63_64	P80	BN80A4	W 63_64 S1 M1LA4
23.3	148	60	W 75_60	P80	BN80A4	W 75_60 S1 M1LA4

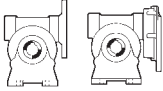
0.75 kW

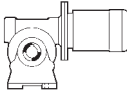
n_2 min ⁻¹	M_2 Nm	i	 	IEC 		
				IE2	IE2	
7.4	557	192	WR 86_192	P80	BE80B4	
8.5	504	168	WR 86_168	P80	BE80B4	
9.5	435	150	WR 75_150	P80	BE80B4	
10.3	436	138	WR 86_138	P80	BE80B4	
11.9	378	120	WR 75_120	P80	BE80B4	
14.3	275	100	W 75_100	P80	BE80B4	W 75_100 S2 ME2SB4
17.9	236	80	W 75_80	P80	BE80B4	W 75_80 S2 ME2SB4
22.3	195	64	W 63_64	P80	BE80B4	W 63_64 S2 ME2SB4
23.8	196	60	W 75_60	P80	BE80B4	W 75_60 S2 ME2SB4

**1.1 kW**

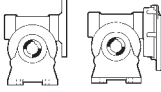
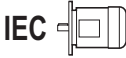
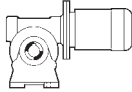
n_2 min ⁻¹	M_2 Nm	i	  IE2	 IE2
10.4	643	138	WR 86_138 P90 BE90S4	
11.9	586	120	WR 86_120 P90 BE90S4	
14.3	437	100	W 86_100 P90 BE90S4	W 86_100 S3 ME2SA4
17.9	379	80	W 86_80 P90 BE90S4	W 86_80 S3 ME3SA4
22.3	322	64	W 86_64 P90 BE90S4	W 86_60 S3 ME3SA4

1.5 kW

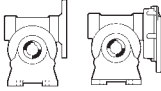
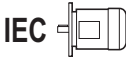
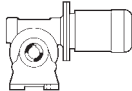
n_2 min ⁻¹	M_2 Nm	i	  IE2	 IE2
11.9	792	120	WR 86_120 P90 BE90LA4	
17.9	512	80	W 86_80 P90 BE90LA4	W 86_80 S3 ME3SB4
22.3	435	64	W 86_64 P90 BE90LA4	W 86_60 S3 ME3SB4

41 ABMESSUNGEN

VF 49_F - VFR 49_F

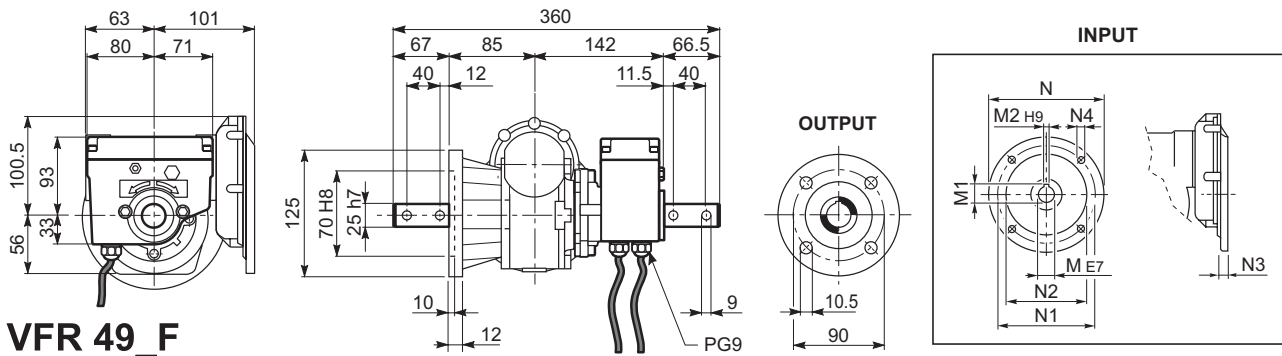
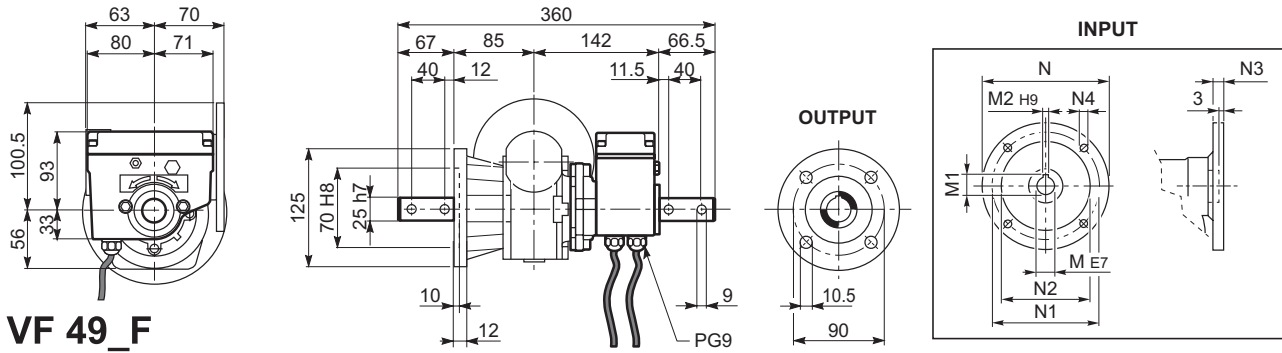

	M	M1	M2	N	N1	N2	N3	N4
VF 49_P 63	11	12.8	4	140	115	95	10.5	9.5
VF 49_P 71	14	16.3	5	160	130	110	10.5	9.5
VFR 49_P 63	11	12.8	4	140	115	95	11	M8x19



W 63 UFC_M/ME - W 63 UFC - WR 63 UFC

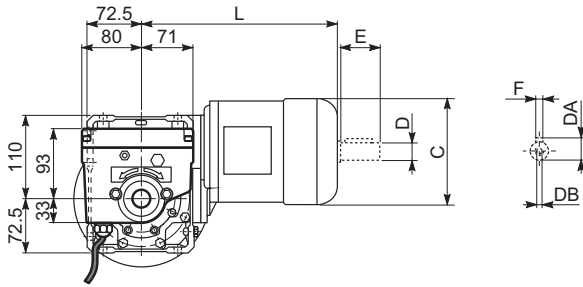

W 63 UFC_M/ME

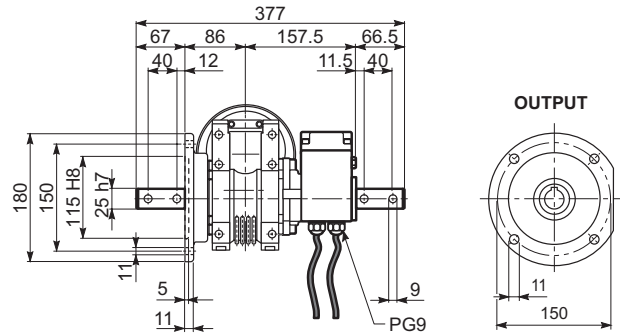

	C	D	DA	DB	E	F	L
W 63_S1 M1L	138	14	16	M5	30	5	289
W 63_S2 ME2S	156	19	21.5	M6	40	6	317

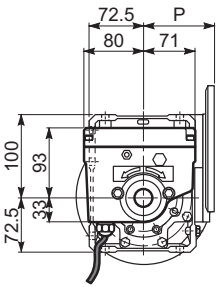

W 63 UFC

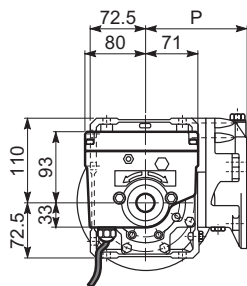
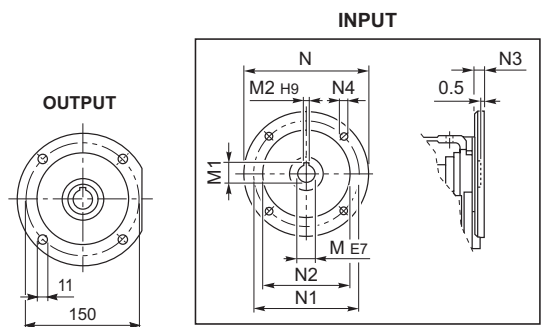
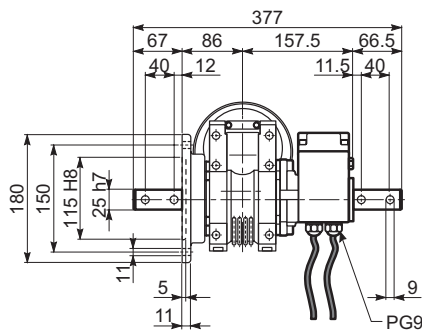

WR 63 UFC

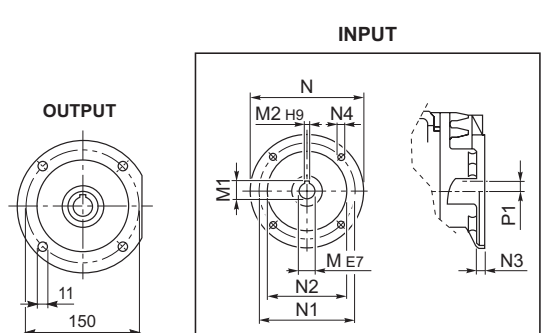
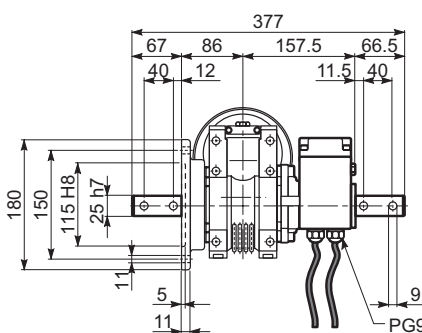

	M	M1	M2	N	N1	N2	N3	N4	P	P1
W 63_P 71	14	16.3	5	160	130	110	11	9	95	-
W 63_P 80	19	21.8	6	200	165	130	12	11.5	102	-
W 63_P 90	24	27.3	8	200	165	130	12	11.5	102	-
WR 63_P 63	11	12.8	4	140	115	95	10	M8x10	133.5	11.42
WR 63_P 71	14	16.3	5	160	130	110	10	M8x10	133.5	11.42

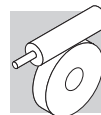

W 75 UFC_M/ME - W 75 UFC - WR 75 UFC

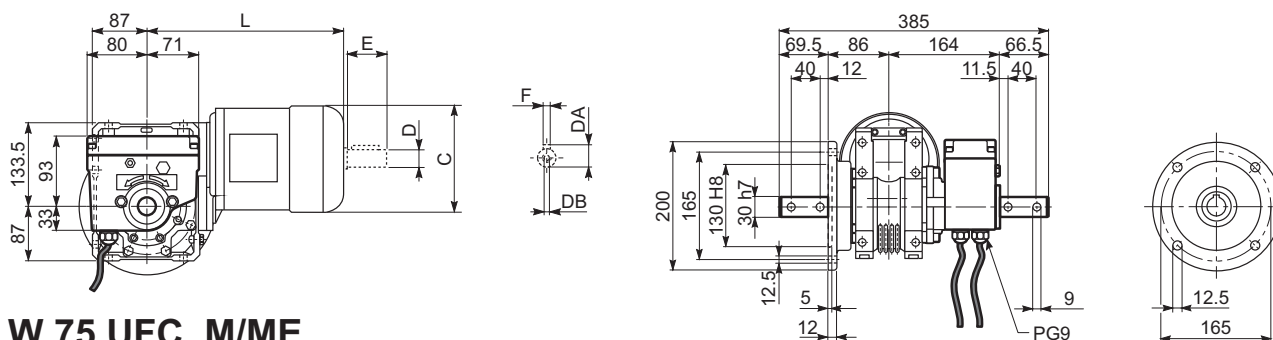

W 75 UFC_M/ME

	C	D	DA	DB	E	F	L
W 75_S1 M1L	138	14	16	M5	30	5	308
W 75_S2 ME2S	156	19	21.5	M6	40	6	333
W 75_S3 ME3S	193	28	31	M10	60	8	376
W 75_S3 ME3L	193	28	31	M10	60	8	408

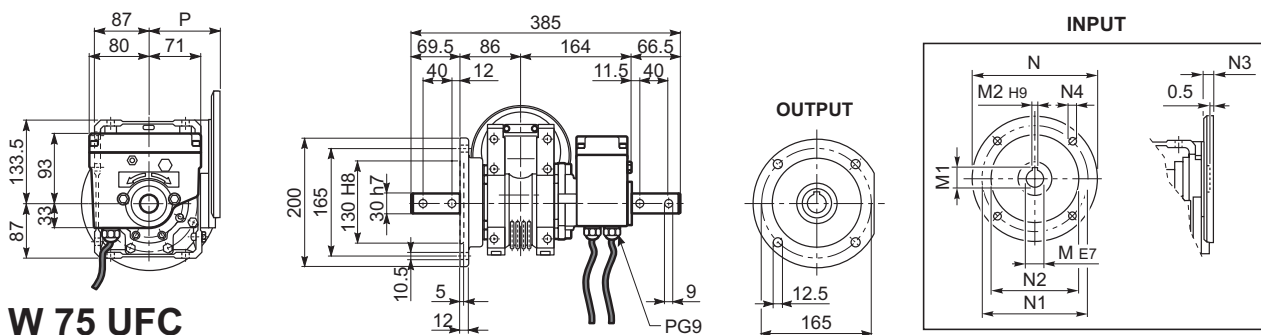

W 75 UFC

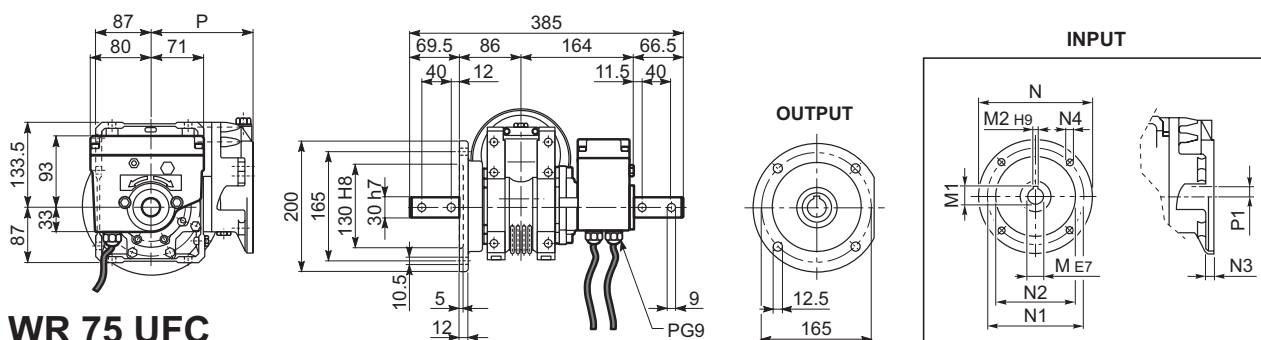

WR 75 UFC

	M	M1	M2	N	N1	N2	N3	N4	P	P1
W 75_P 71	14	16.3	5	160	130	110	11	9	112	-
W 75_P 80	19	21.8	6	200	165	130	12	11.5	112	-
W 75_P 90	24	27.3	8	200	165	130	12	11.5	112	-
WR 75_P 63	11	12.8	4	140	115	95	10	M8x10	152	23.53
WR 75_P 71	14	16.3	5	160	130	110	10	M8x10	152	23.53
WR 75_P 80	19	21.8	6	200	165	130	12	M10x13	163.5	11
WR 75_P 90	24	27.3	8	200	165	130	12	M10x13	163.5	11



RVS

W 86 UFC_M/ME - W 86 UFC - WR 86 UFC

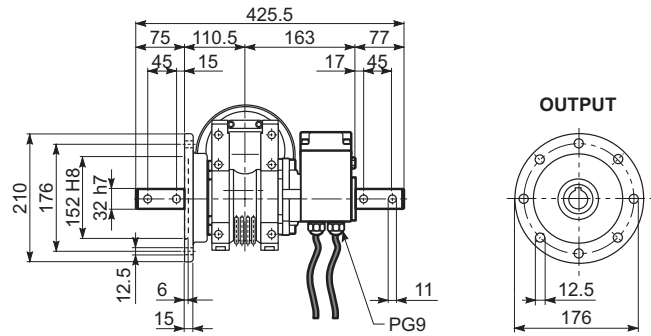
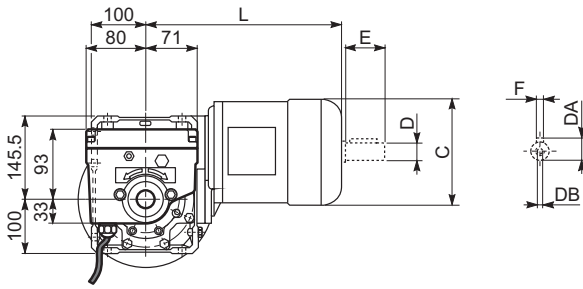

W 86 UFC_M/ME

	C	D	DA	DB	E	F	L
W 86_S1 M1L	138	14	16	M5	30	5	324
W 86_S2 ME2S	156	19	21.5	M6	40	6	349
W 86_S3 ME3S	193	28	31	M10	60	8	392
W 86_S3 ME3L	193	28	31	M10	60	8	424

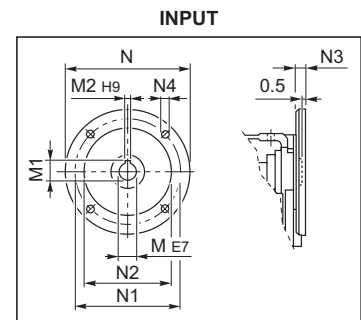
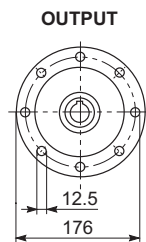
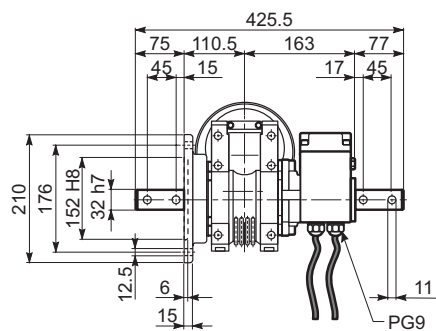
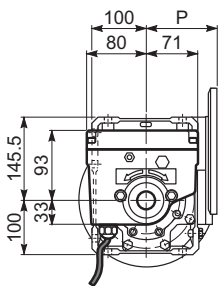

W 86 UFC

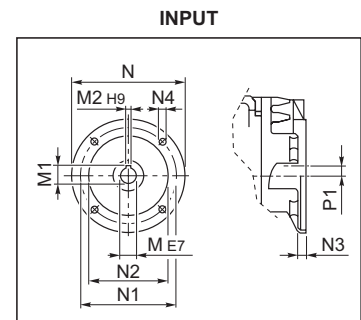
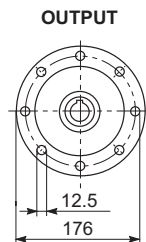
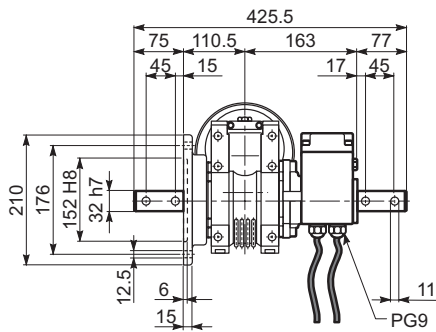
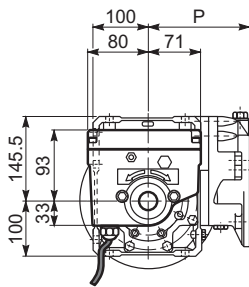

WR 86 UFC

	M	M1	M2	N	N1	N2	N3	N4	P	P1
W 86_P 71	14	16.3	5	160	130	110	11	9	128	-
W 86_P 80	19	21.8	6	200	165	130	12	11.5	128	-
W 86_P 90	24	27.3	8	200	165	130	12	11.5	128	-
WR 86_P 63	11	12.8	4	140	115	95	10	M8x10	168	35.4
WR 86_P 71	14	16.3	5	160	130	110	10	M8x10	168	35.4
WR 86_P 80	19	21.8	6	200	165	130	12	M10x13	179.5	22.9
WR 86_P 90	24	27.3	8	200	165	130	12	M10x13	179.5	22.9

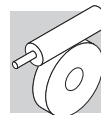

42 OPTIONEN

Endschalter-Varianten

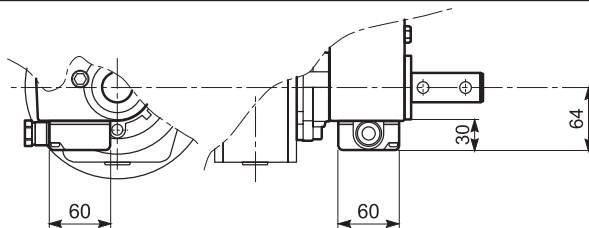
ME

Version mit Klemmenkasten

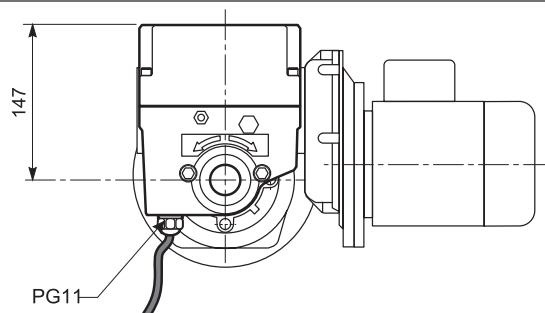
DM

Version mit vier Mikroschaltern



ELEKTROMOTOREN

M1 SYMBOLE UND MAßEINHEITEN

Symbole	Maßeinheiten	Beschreibung	Symbole	Maßeinheiten	Beschreibung
$\cos\varphi$	–	Leistungsfaktor	n	$[\text{min}^{-1}]$	Nennndrehzahl
η	–	Wirkungsgrad	P_B	[W]	Leistungsaufnahme der Bremse bei 20°C
f_m	–	Leistungsfaktorkorrektur	P_n	[kW]	Nennleistung
I	–	Relative Einschaltdauer	P_r	[kW]	Benötigte Leistung
I_N	[A]	Nennstrom	t_1	[ms]	Ansprechzeit Bremse mit Einweg-Gleichrichter
I_S	[A]	Kurzschlussstrom	t_{1s}	[ms]	Ansprechzeit Bremse mit elektronisch gesteuertem Gleichrichter
J_C	[Kgm ²]	Massenträgheitsmoment der Last	t_2	[ms]	Einfallzeit Bremse bei Unterbrechung der Stromversorgung WS
J_M	[Kgm ²]	Massenträgheitsmoment	t_{2c}	[ms]	Einfallzeit Bremse bei Unterbrechung der Stromversorgung WS und GS
K_C	–	Drehmomentfaktor	t_a	[°C]	Umgebungstemperatur
K_d	–	Lastfaktor	t_f	[min]	Betriebsdauer bei gleicher Belastung
K_J	–	Trägheitsmomentfaktor	t_r	[min]	Aussetzzeit
M_A	[Nm]	Mittleres Beschleunigungsmoment	W	[J]	Bremsenergieaufnahme zwischen zwei Nachstellungen
M_B	[Nm]	Bremsmoment	W_{\max}	[J]	Max. Bremsarbeit pro Bremsvorgang
M_N	[Nm]	Nennmoment	Z	[1/h]	Schalhäufigkeit unter Last
M_L	[Nm]	Mittleres Gegenmoment	Z_0	[1/h]	Max. Schalhäufigkeit im Leerlauf (relative Einschaltdauer $I = 50\%$)
M_S	[Nm]	Startmoment			



M2 EINFÜHRUNG

Wirkungsgradklassen und Prüfverfahren

Die Wirkungsgradklassen beschreiben die Effizienz, mit der ein Elektromotor elektrische in mechanische Energie umwandelt. In Europa erfolgte die Energieklassifizierung von Niederspannungsmotoren auf freiwilliger Basis unter Bezugnahme auf die Klassen Eff1/Eff2/Eff3. Andere Länder benutzten eigene nationale Klassifizierungssysteme, die oftmals vom europäischen System abwichen. Diese normative Unsicherheit hat die Hersteller dazu bewogen, eine internationale Harmonisierung anzustreben, die zur Ausgabe der IEC-Norm (International Electrotechnical Commission) IEC 60034-30-1, "Wirkungsgradklassen für eintourige Drehstrom-Käfigläufer-Asynchronmotoren (IE-Code)" führte.

Die neue Norm:

- definiert die neuen Wirkungsgradklassen;

IE1 (Standard-Wirkungsgrad)

IE2 (hoher Wirkungsgrad)

IE3 (Premium-Wirkungsgrad)

- liefert einen gemeinsamen internationalen Bezug für die Klassifizierung von Elektromotoren wie auch für die gesetzgebenden Aktivitäten der Länder;

- führt ein neues Messverfahren des Wirkungsgrads in Übereinstimmung mit der Norm IEC 60034-1-2:2007 ein.

In der nachfolgenden Tabelle ist die Entsprechung zwischen den wesentlichen Klassifikationen aufgeführt.

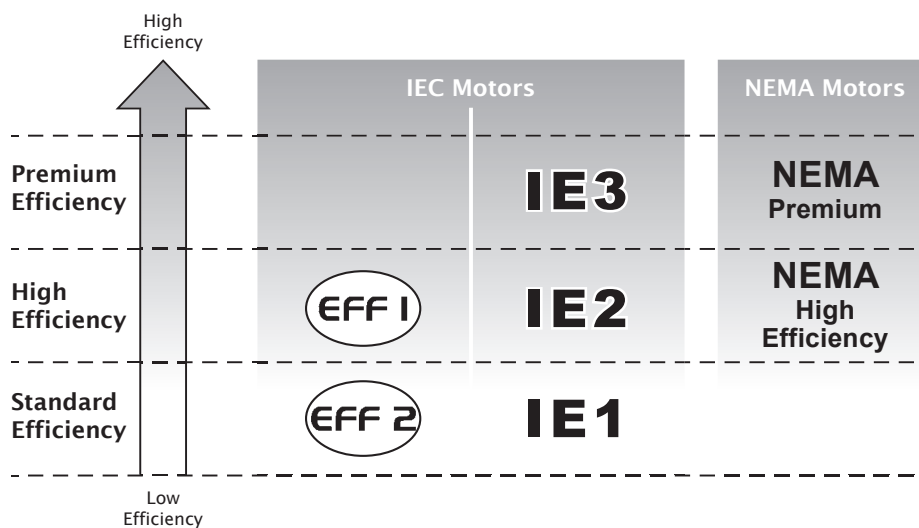



EG Verordnung Nr. 640/2009

Die Norm IEC 60034-30-1 liefert die technischen Leitlinien, bestimmt aber nicht die gesetzlichen Vorgaben bezüglich der Anforderungen für die Anwendung einer bestimmten Wirkungsgradklasse. Diese Anforderungen sind durch die Richtlinien und nationalen Gesetze spezifiziert. Die Verordnung vom 22. Juli 2009 zur Durchführung der Richtlinie 2005/32/EG legt diese Anforderungen fest, spezifiziert die Kriterien für die umweltgerechte Gestaltung der Elektromotoren und bestimmt das Wirkungsgradniveau nach folgendem Zeitplan:

- **16.06.2011:** Die Elektromotoren müssen mindestens der Wirkungsgradklasse **IE2** entsprechen
- **01.01.2015:** Die Elektromotoren mit einer Nennausgangsleistung zwischen 7.5 kW und 375 kW müssen mindestens der Wirkungsgradklasse **IE3** entsprechen, oder der Klasse **IE2**, wenn diese über einen Frequenzumrichter angesteuert werden.
- **01.01.2017:** Die Elektromotoren mit einer Nennausgangsleistung zwischen 0.75 kW und 375 kW müssen mindestens der Wirkungsgradklasse **IE3** entsprechen, oder der Klasse **IE2**, wenn diese über einen Frequenzumrichter angesteuert werden.

Geltungsbereich und Ausnahmen

Die Verordnung (EG) Nr. 640/2009 gilt für eintourige 2-, 4- bzw. 6-polige Dreiphasen 50 oder 60 Hz Käfigläufer-Induktionsmotoren mit Nennausgangsleistungen zwischen 0,75 kW und 375 kW, einer Nennspannung bis 1000 V und der Auslegung für Dauerbetrieb (S1).

Diese Verordnung gilt nicht für:

- Bremsmotoren.
- Motoren, die dafür ausgelegt sind, ganz in eine Flüssigkeit eingetaucht betrieben zu werden.
- vollständig in ein Produkt (z.B. Getriebe, Pumpen, Ventilatoren) eingebaute Motoren, deren Energieeffizienz nicht unabhängig von diesem Produkt erfasst werden kann.
- Motoren, die speziell für den Betrieb unter folgenden Bedingungen ausgelegt sind:
 - in Höhen über 4000 Meter über dem Meeresspiegel;
 - bei Umgebungstemperaturen über 60 °C;
 - bei Betriebshöchsttemperaturen über 400 °C;
 - bei Umgebungstemperaturen unter -30 °C (beliebiger Motor) oder unter 0 °C (Wassergekühlte Motoren);
 - bei Kühlflüssigkeitstemperaturen am Einlass eines Produkts unter 0 °C oder über 32 °C;
 - in explosionsgefährdeten Bereichen im Sinne der Richtlinie 94/9/EG.



M3 ALLGEMEINE EIGENSCHAFTEN

M3.1 Produktprogramm

Die Dreiphasen-Asynchronmotoren BX, BE, BN, MX, ME und M aus dem Produktprogramm von BONFIGLIOLI RIDUTTORI gibt es in den Grundbauformen IMB5, IMB14 und deren Ableitungen mit folgenden Polzahlen: 2, 4, 6, 2/4, 2/6, 2/8 und 2/12.

Es handelt sich um Käfigläufermotoren mit Lüftern für industrielle Anwendungen.

Die BX, BE, MX, ME Motoren sind in der Standardausführung für die Nennspannungen 230/400V Δ/Y (400/690V Δ/Y für die Größen von BX/BE 160 und BX/BE 180) 50 Hz, mit einer Toleranz von $\pm 10\%$ vorgesehen. Die BN/M Motoren sind in der Standardausführung für eine Nennspannung von 230/400V Δ/Y (400/690V Δ/Y für die Größen von BE 160 ... BE 200) 50 Hz, mit einer Toleranz von $\pm 10\%$ vorgesehen.

M3.2 Normen

Die in diesem Katalog beschriebenen Motoren sind in Übereinstimmung mit den in der folgenden Tabelle angegebenen einschlägigen Normen und Vereinheitlichungsrichtlinien konstruiert worden.

(F01)

Titel	CEI	IEC
Allgemeine Vorschriften für drehende elektrische Maschinen	CEI EN 60034-1	IEC 60034-1
Anschlussbezeichnungen und Drehrichtung von drehenden elektrischen Maschinen	CEI 2-8	IEC 60034-8
Verfahren zur Kühlung von elektrischen Maschinen	CEI EN 60034-6	IEC 60034-6
Standardisierte Abmessungen und Leistungen von drehenden elektrischen Maschinen	EN 50347	IEC 60072
Klassifizierung der Schutzart von drehenden elektrischen Maschinen	CEI EN 60034-5	IEC 60034-5
Geräuschgrenzwerte	CEI EN 60034-9	IEC 60034-9
Kennzeichnung der Bauformen, Aufstellung und Klemmkastenlage	CEI EN 60034-7	IEC 60034-7
IEC Normspannungen	CEI 8-6	IEC 60038
Mechanische Schwingungen (Verfahren und Grenzwerte) für elektrischen Maschinen	CEI EN 60034-14	IEC 60034-14
Wirkungsgradklassen der eintourigen Drehstrom-Asynchronmotoren mit Käfigläufer (IE-Code)	CEI EN 60034-30-1	IEC 60034-30-1
Genormte Testverfahren zur Bestimmung der Verluste und des Wirkungsgrads	CEI EN 60034-2-1	IEC 60034-2-1

Die Motoren entsprechen außerdem den an die IEC-Norm 60034-1 angepassten ausländischen Normen, die in der folgenden Tabelle genannt werden.

(F02)

DIN VDE 0530	Deutschland
BS5000 / BS4999	Großbritannien
AS 1359	Australien
NBNC 51 - 101	Belgien
NEK - IEC 34	Norwegen
NF C 51	Frankreich
OEVE M 10	Österreich
SEV 3009	Schweiz
NEN 3173	Niederlande
SS 426 01 01	Schweden



M3.3 Richtlinien 2006/95/EG (LVD) und 2004/108/EG (EMC)

Die Motoren der Serie BX, BE, BN, MX, ME und M entsprechen den Anforderungen der Richtlinien 2006/95/EG (Richtlinie - Niederspannung) und 2004/108/EG (Richtlinie - elektromagnetische Kompatibilität) und sind mit dem CE-Zeichen ausgestattet. Im Hinblick auf die Richtlinie EMC entspricht die Konstruktion den Normen CEI EN 60034-1, EN 61000-6-2, EN 61000-6-4.

Die Motoren mit dem Bremsentyp FD und AFD fallen, falls mit dem entsprechenden Entstörfilter am Eingang des Gleichrichters ausgestattet (Option **CF**), unter die Emissionsgrenzwerte, die von der Norm EN 61000-6-3:2007 "Elektromagnetische Kompatibilität - Allgemeine Norm für Emissionen - Teil 6-3: Wohngebiete, Handels- und Leichtinduszriezonen" vorgesehen werden. Die Motoren entsprechen darüber hinaus den von der Norm CEI EN 60204-1 "Elektrische Maschinenausstattung" gegebenen Vorschriften.

Es liegt in der Verantwortung des Herstellers oder der Montagefirma der Ausrüstung, in der die Motoren als Komponenten montiert werden, die Sicherheit und die Übereinstimmung mit den Richtlinien des Endprodukts zu gewährleisten.

M3.4 Toleranzen

Die Normen CEI EN 60034-1, lassen die in der nachfolgenden Tabelle genannten Toleranzen für die angegebenen Nennwerte zu:

(F03)

$-0.15 (1 - \eta) \quad P \leq 50\text{kW}$	Wirkungsgrad
$-(1 - \cos\phi)/6 \quad \text{min } 0.02 \quad \text{max } 0.07$	Leistungsfaktor
$\pm 20\% \quad *$	Schlupf
+20%	Strom bei blockiertem Läufer
-15% +25%	Drehmoment bei blockiertem Läufer
-10%	Max. Drehmoment

(*) $\pm 30\%$ für Motoren mit $P_n < 1 \text{ kW}$



M4 BEZEICHNUNG FÜR MOTOREN MIT PREMIUM WIRKUNGSGRAD

MOTOR

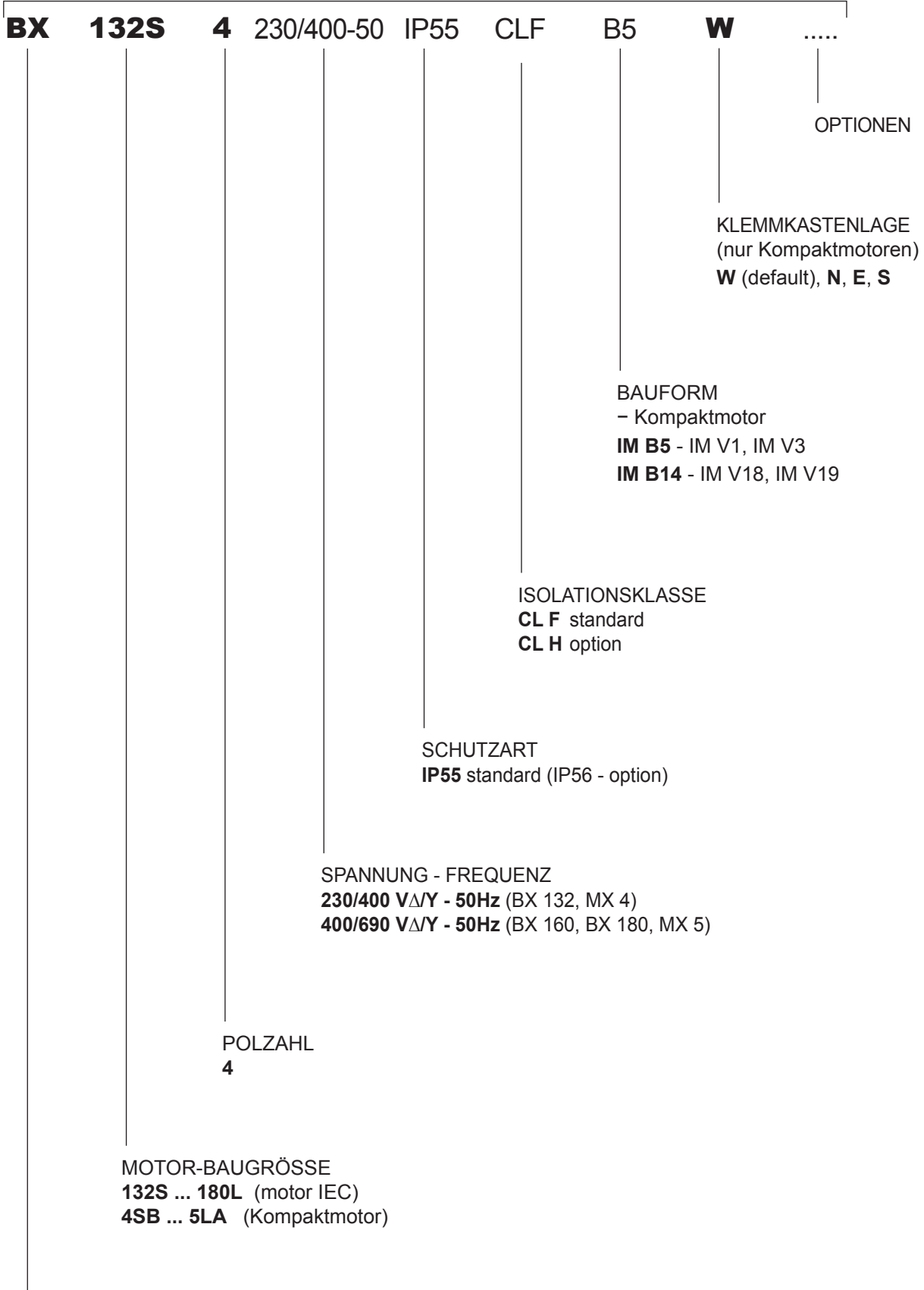

MOTORTYP

BX = IEC Dreiphasen, Klasse IE3 **MX** = kompakt Dreiphasen, Klasse IE3



M4.1 BEZEICHNUNG FÜR MOTOR MIT HOHEM WIRKUNGSGRAD

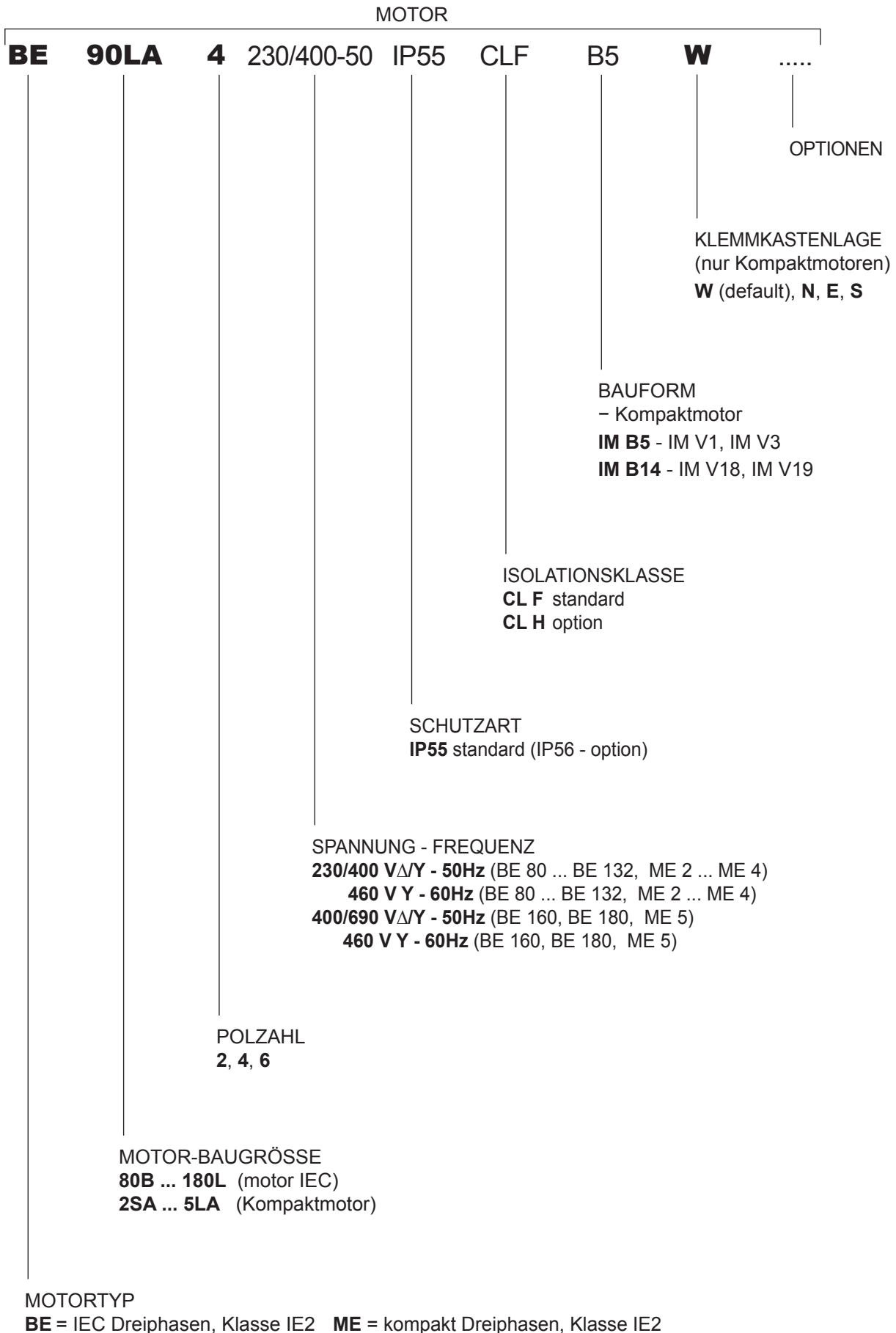



M4.2 BEZEICHNUNG FÜR MOTOR MIT STANDARD WIRKUNGSGRAD

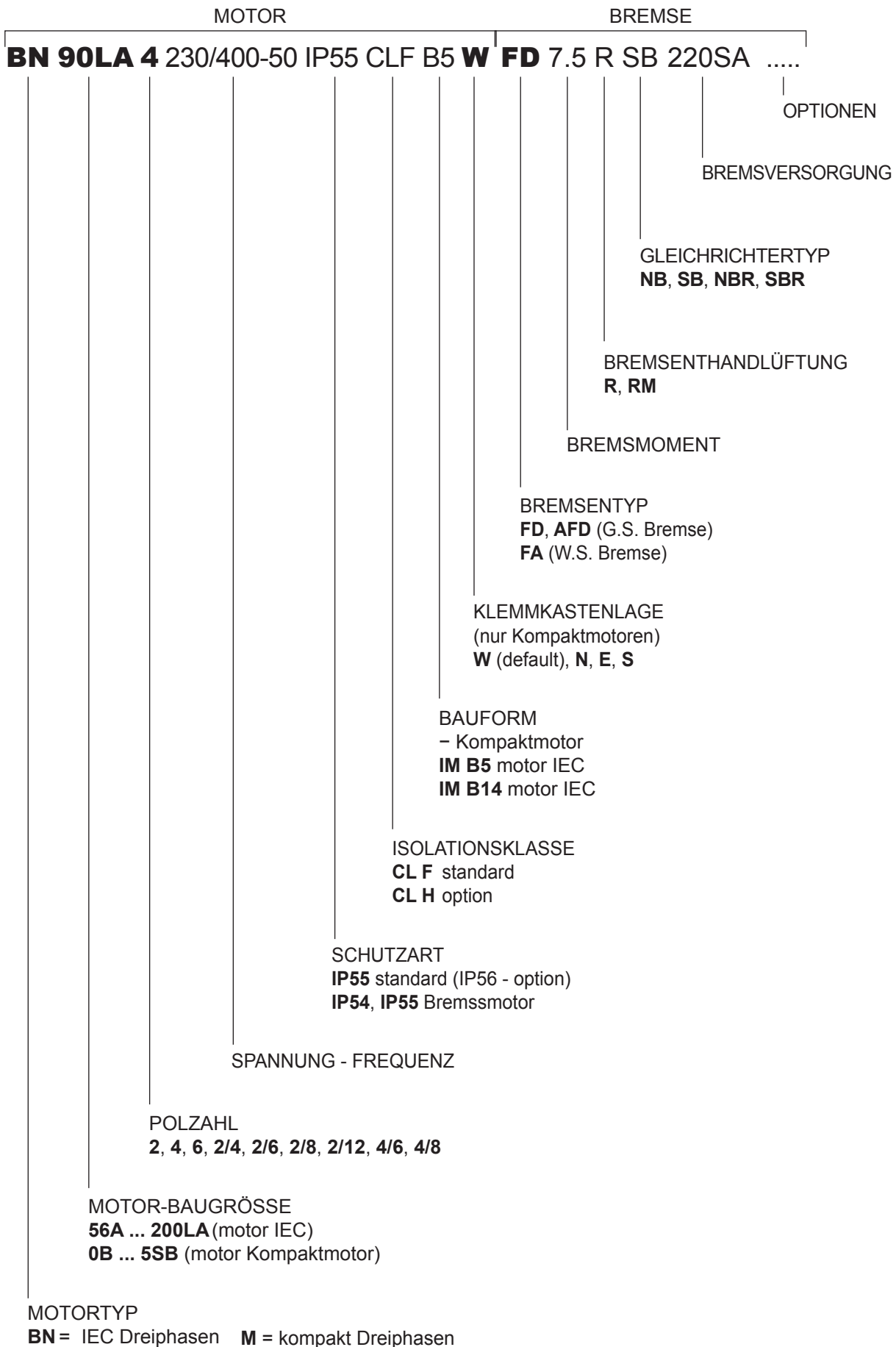



M4.3 Optionen

(F04)

Beschreibung		Standard	Option	Seite	
Spannung		230/400/50		511	
Schutzart	BX - BE - BN - MX - ME - M	IP 55	IP 56	507	
	BN_FD - BN_AFD - BN_FA M_FD - M_AFD - M_FA	IP 54	IP 55		
Isolierstoffklasse		CLF	CLH	514	515
Bauform	BX - BE - BN	B5 B5 R	B14 B14 R	506	

Standardwerte bei Lieferung falls nicht anders spezifiziert.

M4.4 Optionen

(F05)

Beschreibung	Werte						Verfügbarkeit	Seite	
	D3	K1	E3						
Thermische Wicklungsschutz	D3	K1	E3				BX - BE - BN MX - ME - M	533	534
Auf 50 Hz genormte Leistung	PN						BN M	513	
Signalrückführungen (Drehgeber)	EN1	EN2	EN3	EN4	EN5	EN6	BX - BE - BN MX - ME - M	542	
Wicklungsheizung	H1	NH1					BX - BE - BN MX - ME - M	540	
Tropenschutz der Motorwicklungen	TP						BX - BE - BN MX - ME - M	541	
Zweites Wellenende	PS						BX - BE - BN MX - ME - M	541	
Rotorauswuchtung mit Grad B	RV						BX - BE - BN MX - ME - M	542	
Schutzdächer	RC	TC					BX - BE - BN MX - ME - M	541	542
Fremdlüfter	U1	U2*					BX - BE - BN MX - ME - M	540	541
Zertifizierte Ausführung	CUS						BE - BN ME - M	513	
China Compulsory Certification	CCC						BE - BN ME - M	514	
Steckverbinder	CON						BX - BE - BN MX - ME - M	534	
Oberflächenschutz	C_						BX - BE - BN MX - ME - M	544	
Lackierung	RAL						BX - BE - BN MX - ME - M	544	
Zertifikate	ACM						BX - BE - BN MX - ME - M	545	
Prüfzertifikat	CC						BX - BE - BN MX - ME - M	545	
Rücklauf Sperre	AL	AR					MX - ME - M	545	
Betriebsart	S2	S3	S9				BN M	515	

* Nur für Motoren BN und M



M4.5 Bremsoptionen

(F06) Beschreibung	Werte				Verfügbarkeit	Seite
Bremsmoment	Bezogen auf speziellen Bremsentyp					522 526 529
Manueller Bremslufthebel	R	RM			BN M	531
Orientierung des Bremslösehebel	AB	AA	AC	AD	BN M	532
Stromversorgung der Bremse	NB	NBR	SB	SBR	BN M	521 525
Schwungrad für Sanftanlauf	F1				BN M	533
Kapazitiver Filter	CF				BN M	533
Separate Bremsversorgung (*)	...SA	...SD			BN M	521 525 529
Bremsenfunktionskontrolle	MSW				BN M	537
Zusätzliche Kabeldurchführung für Bremsmotoren	IC				BN M	537

(*) Spannungswert eintragen.

■ Standardwerte bei Lieferung falls nicht anders spezifiziert.

M4.6 Beispiel für Typenschild

1	IEC EN 60034	Bonfiglioli Riduttori	CE	4
	3~Mot BE 90LA 4		Cod. 8U09030001	
2	No 1003001 - 6954785	S 1	IM B 5 15,1 kg	5
	kW 1,5	CL F IP 55	Amb 40 °C	
	Hz	V ± 10%	A min ⁻¹ cos φ	
	50 ○	230/400 Δ/Y	6,1/3,5 1430 ○ 0,74	
3	60	265/460 Δ/Y	5,4/3,1 1730 0,73	
	50Hz-IE2	83,5(100%) - 83,0(75%) - 80,0(50%)		6
	60Hz-IE2	84,5(100%) - 83,9(75%) - 80,7(50%)		

- | | |
|--|---|
| ① Identifikationscode
BONFIGLIOLI Motor | ④ Motor-Codenummer |
| ② Seriennummer | ⑤ Betriebsart: S1
Dauerbetrieb |
| ③ Nennspannung | ⑥ Wirkungsgradklasse IE
bei: 4/4 - 3/4 - 2/4 Belastung |



M5 MECHANISCHE EIGENSCHAFTEN

M5.1 Bauformen

Die Motoren der Serie BX, BE und BN weisen die in der nachstehenden Tabelle angegebene Bauform gemäß den Normen EN 60034-7 (BX/BE), CEI EN 60034-14 (BN). auf.

Die Bauformen sind:

IM B5 (Grundmodell)

IM V1, IM V3 (Ableitungen)

IM B14 (Grundmodell)

IM V18, IM V19 (Ableitungen)

Die Motoren in der Bauform IM B5 können auch in den Einbaulagen IM V1 und IM V3 eingesetzt werden; die Motoren in der Bauform IM B14 können auch in den Einbaulagen IM V18 und IM V19 eingesetzt werden.

In diesen Fällen ist auf dem Leistungsschild des Motors die Bauform IM B5 oder IM B 14 angegeben.

Bei Bauformen mit vertikaler Lage des Motors und nach unten gerichteter Welle wird die Ausführung mit Schutzdach empfohlen (bei Bremsmotoren stets vorzusehen). Diese Option muß zum Bestellzeitpunkt angegeben werden, da sie in der Grundausführung nicht berücksichtigt ist.

(F07)

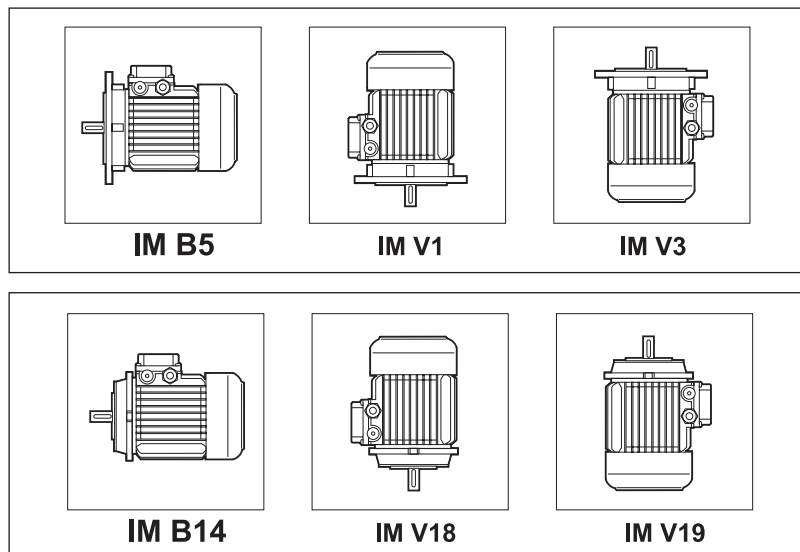



Die Motoren mit Flansch können mit reduzierten Wellen und Flanschmaßen geliefert werden in der nachstehenden Tabelle - Hinrichtungen **B5R**, **B14R**.

(F08)

	BN 71	BE/BN 80	BE/BN 90	BE/BN 100	BE/BN 112	BX/BE/BN 132
	DxE - Ø					
B5R ⁽¹⁾	11x23 - 140	14x30 - 160	19x40 - 200	24x50 - 200	24x50 - 200	28x60 - 250
B14R ⁽²⁾	11x23 - 90	14x30 - 105	19x40 - 120	24x50 - 140	—	—

(1) Flansch mit durchgehenden Bohrungen

(2) Flansch mit Gewindebohrungen

M5.2 Schutzart

IP..















In der nachstehenden Tabelle werden die jeweils zur Verfügung stehenden Schutzarten zusammengefasst.

Unabhängig von der spezifischen Schutzart müssen die im Freien installierten Motoren vor direkter Sonneneinstrahlung geschützt werden. Im Fall einer senkrechten Montage mit Wellenende nach unten, sollte darüber hinaus das Schutzdach bestellt werden, das vor dem Eindringen von Wasser und festen Fremdkörpern schützt (Option **RC**).

(F09)

		IP 54	IP 55	IP 56
BX - BE - BN	MX - ME - M		standard	
BN_FD BN_AFD BN_FA	M_FD M_AFD M_FA	standard		



IP			5			5		
0		Nicht geschützt	0		Nicht geschützt			
1		Geschützt gegen feste Fremdkörper mit $\varnothing \geq 50$ mm	1		Geschützt gegen senkrecht einfallendes Tropfwasser			
2		Geschützt gegen feste Fremdkörper mit $\varnothing \geq 12.5$ mm	2		Geschützt gegen senkrecht einfallendes Tropfwasser bei Neigung bis 15°			
3		Geschützt gegen feste Fremdkörper mit $\varnothing \geq 2.5$ mm	3		Regenwassergeschützt			
4		Geschützt gegen feste Fremdkörper mit $\varnothing \geq 1.0$ mm	4		Spritzwassergeschützt			
5		Staubgeschützt	5		Wasserstrahigeschützt			
6		Kein Staubeintritt	6		Gegen starke Wasserstrahlen geschützt			
			7		Kurzzeitig wasserdicht			
			8		Nachhaltig wasserdicht			

M5.3 Kühlung

Die Motoren werden mittels Eigenbelüftung gekühlt (IC 411 gemäss CEI EN 60034-6) und sind mit einem Radiallüfterrad aus Kunststoff ausgestattet, welches in beiden Drehrichtungen wirksam ist. Bei der Installation muß sichergestellt werden, dass die Lüfterradabdeckung soweit vom nächsten Bauteil entfernt ist, daß der Lufteintritt nicht behindert wird und dass der Motor und (falls vorhanden) die Bremse problemlos gewartet werden können.

Die Motoren können auf Anfrage mit einem unabhängig gespeisten Fremdlüfter geliefert werden (Option **U1**). Diese Ausführung sollte eingesetzt werden, falls der Motor über einen Frequenzumrichter bei kleinen Drehzahlen oder bei hoher Schalzhäufigkeit betrieben wird.

M5.4 Drehrichtung

Der Betrieb in beiden Drehrichtungen ist möglich.

Schließt man die Klemmen U1, V1, W1 an die Phasen L1, L2, L3 an, dreht sich der Motor, mit Sicht auf die Motorwelle, im Uhrzeigersinn. Eine Drehung im Gegenuhrzeigersinn erhält man, indem man zwei Phasen tauscht.

M5.5 Geräuschpegel

Der Geräuschpegel wurde entsprechend der in der Norm ISO 1680 angegebenen Methode gemessen und liegt innerhalb der zulässigen Grenzwerte der Norm CEI EN 60034-9.



M5.6 Auswuchtung und Schwingstärke

Die Motoren werden dynamisch mit einer halben Passfeder ausgewuchtet und entsprechen dem Schwingstärkegrad A der Norm CEI EN 60034-14.

M5.7 Motorklemmkasten



Der Klemmkasten hat ein 6-poliges Klemmbrett für einen Anschluss über Kabelschuhe. Im Klemmkasten ist ein Erdungsanschluss für den Anschluss des Schutzleiters vorgesehen. Die Abmessungen der Anschlüsse werden in der nachstehenden Tabelle angegeben.

Für Informationen über die Bremsversorgung verweisen wir an dieser Stelle auf den Par. 8, 9 (Bremsstyp FD und AFD), 10, 11 (Bremsstyp FA).

Bei den Bremsmotoren befindet sich der Gleichrichter mit den erforderlichen Anschlussklemmen für die Stromversorgung der Bremse innerhalb des Klemmkastens.

Die elektrischen Anschlüsse müssen entsprechend den Schaltplänen, die sich im Inneren der Klemmkästen befinden, vorgenommen werden oder anhand der Angaben in den Betriebsanleitungen.



(F10)

		Klemmen	Gewinde	Max. leiter-querschnitt mm ²
BE 80, BE 90 BN 56 ... BN 71 BN 80, BN 90	ME2 M05, M1 M2	6	M4	2.5
BE 100 ... BX 132 - BE 132 BN 100 ... BN 112 BN 132 ... BN 160MR	ME3, MX4 - ME4 M3 MX4 - M4	6	M5	6
BX 160 - BE 160 BN 160M ... BN 180M	ME 5 MX5 - M5	6	M6	16
BX 180 - BE 180 BN 180L ... BN 200L	– –	6	M8	25

M5.8 Kabeleingang

Unter Berücksichtigung der Norm EN 50262 verfügen die Kabeleingänge in die Klemmkästen über metrische Gewinde, deren Maße, der nachstehenden Tabelle entnommen werden können.

(F11)

		Kabeleingänge		maximal zulässiger Kabeldurchmesser [mm]
BN 63	M05	2 x M20 x 1.5	1 Bohrung pro Seite	13
BN 71	M1	2 x M25 x 1.5		17
BE 80, BE 90 BN 80, BN 90	ME2 M2	2 x M25 x 1.5		17
BE 100, BE 112 BN 100	ME3 M3	2 x M32 x 1.5	2 Bohrungen pro Seite	21
		2 x M25 x 1.5		17
BN 112	–	2 x M32 x 1.5		21
		2 x M25 x 1.5		17
BX 132 - BE 132 BN 132...BN 160MR	MX4 - ME4 M4	4 x M32 x 1.5		21
BX 160 - BE 160, BX 180 - BE 180 BN 160M...BN 200L	MX5 - ME5 M5	2 x M40 x 1.5		Orientierbar 4 x 90°



M5.9 Lager

Bei den Lagern handelt es sich um Radialkugellager mit Dauerschmierung.

Die verwendeten Typen sind in der nachfolgenden Tabelle angegeben.

Die Lebensdauer L10h der Lager, ohne Einfluss externer Kräfte, beträgt mehr als 40.000 Stunden (Berechnung gemäß ISO 281).

DE = Wellenseite

NDE = Lüfterseite

(F12)

	DE	M	NDE
	M, M_FD, M_AFD, M_FA		M_FD, M_AFD, M_FA
M05	6004 2Z C3	6201 2Z C3	6201 2RS C3
M1	6004 2Z C3	6202 2Z C3	6202 2RS C3
ME2 - M2	6007 2Z C3	6204 2Z C3	6204 2RS C3
ME3 - M3	6207 2Z C3	6206 2Z C3	6206 2RS C3
MX4 - ME4 - M4	6309 2Z C3	6308 2Z C3	6308 2RS C3
MX5 - ME5 - M5	6309 2Z C3	6309 2Z C3	6309 2RS C3

	DE	BX, BE, BN	NDE
	BX, BE, BN, BN_FD, BN_AFD, BN_FA		BN_FD, BN_AFD, BN_FA
BN 56	6201 2Z C3	6201 2Z C3	–
BN 63	6201 2Z C3	6201 2Z C3	6201 2RS C3
BN 71	6202 2Z C3	6202 2Z C3	6202 2RS C3
BE 80 BN 80	6204 2Z C3	6204 2Z C3	6204 2RS C3
BE 90 BN 90	6205 2Z C3	6205 2Z C3	6305 2RS C3
BE 100 BN 100	6206 2Z C3	6206 2Z C3	6206 2RS C3
BE 112 BN 112	6306 2Z C3	6306 2Z C3	6306 2RS C3
BX 132 BE 132 BN 132	6308 2Z C3	6308 2Z C3	6308 2RS C3
BN 160MR	6309 2Z C3	6308 2Z C3	6308 2RS C3
BX 160M/L BE 160M/L BN 160M/L	6309 2Z C3	6309 2Z C3	6309 2RS C3
BN 180M	6310 2Z C3	6309 2Z C3	6309 2RS C3
BX 180M/L BE 180M/L BN 180L	6310 2Z C3	6310 2Z C3	6310 2RS C3
BN 200L	6312 2Z C3	6310 2Z C3	6310 2RS C3



M6 ELEKTRISCHE EIGENSCHAFTEN



M6.1 Spannung

Die einpoligen Motoren sind in der Standardausführung für eine Nennspannung von 230/400V Δ/Y oder 400/690V Δ/Y 50 Hz mit einer Spannungstoleranz $\pm 10\%$, bezogen auf die Typenschildangabe, ausgelegt. Für alle BN und M Motoren, deren Spannungs-/Frequenzangabe nicht in der nachfolgenden Übersicht enthalten ist, gelten reduzierte Spannungstoleranzen von $\pm 5\%$.

Bei einem Betrieb an den Toleranzgrenzen kann die Temperatur die vorgesehene Isolationsklasse um 10 K überschreiten. Diese Motoren eignen sich für einen

Betrieb im Europäischen Versorgungsnetz mit einer Spannung, die den in der Veröffentlichung IEC 60038 angegebenen Werten entspricht.

(F13)

Effizienzklasse			$V_{\text{mot}} \pm 10\%$ 3 ~	Ausführung
IE3	BX 132	MX 4	230 / 400 V - Δ/Y - 50 Hz	standard
	BX 160, BX 180	MX 5	400 / 690 V - Δ/Y - 50 Hz	standard
IE2	BE 80 ... 132	ME 2 ... ME 4	230 / 400 V - Δ/Y - 50 Hz	standard
			460 V Y - 60 Hz ¹	standard
	BE 160, BE 180	ME 5	400 / 690 V - Δ/Y - 50 Hz	Auf Anfrage, ohne Aufpreis
			460 V Δ - 60 Hz ¹	standard
IE1	BN 56 ... BN 132	M0 ... M4	230 / 400 V - Δ/Y - 50 Hz	standard
			400 / 690 V - Δ/Y - 50 Hz	Auf Anfrage, ohne Aufpreis
	BN 160 ... 200	M5	460 V Y - 60 Hz	standard
			400 / 690 V - Δ/Y - 50 Hz	standard
			460 V Δ - 60 Hz	standard

¹ nur 4polige Motoren

Die polumschaltbaren Motoren sind nur für eine Standardversorgung von 400V - 50 Hz ausgelegt, Toleranzen gelten gem. CIE EN 60034-1.

In der nachfolgenden Tabelle werden die verschiedenen Wicklungsanschlüsse in Abhängigkeit von den jeweiligen Polzahlen angegeben.

(F14)

Polzahl		Wicklungsanschluß
2	BE 80 ... BE 160, BN 63 ... BN 200	Δ / Y ⁽²⁾
4	BX 132 ... BX 180 BE 80 ... BE 180, BN 56 ... BN 200	
6	BE 90 ... BE 160, BN 63 ... BN 200	
8	BN 71 ... BN 132	
2/4	BN 63 ... BN 132	Δ / YY (Dahlander)
2/6	BN 71 ... BN 132	Y / Y (Zwei wicklungen)
2/8	BN 71 ... BN 132	
2/12	BN 80 ... BN 132	
4/6	BN 71 ... BN 132	
4/8	BN 80 ... BN 132	Δ / YY (Dahlander)





⁽²⁾ Motoren mit dem Spannungsverhältnis 2 (z. B. 230/460V - 60Hz) werden mit einem 9-poligen Klemmbrett in $\Delta\Delta/\Delta$ oder YYY/Y - Schaltung gefertigt (Ausnahme 6-polig BN 63 Δ/Y)



M6.2 Frequenz

Die Leistungsangabe auf dem Typenschild BN / M von 60 Hz Motoren entspricht den Daten aus der folgenden Tabelle:

(F15)

			P _n [kW]					P _n [kW]		
			2P	4P	6P			2P	4P	6P
BN 56A	–	–	–	0.1	–	BN 112M	M3LB	4.7	3.6	2.0
BN 56B	M 0B	–	–	0.1	–	–	M3LC	–	4.7	2.5
BN 63A	M 05A	0.2	0.1	0.1	BN 132S	M4SA	–	6.5	3.5	
BN 63B	M 05B	0.3	0.2	0.1	BN 132SA	M4SA	6.3	–	–	
BN 71A	M 05C	0.5	0.3	0.2	BN 132SB	M4SB	8.7	–	–	
BN 71B	M 05SD	0.7	0.5	0.3	BN 132M	M4LA	11.0	–	–	
BN 80A	M 1LA	0.9	0.7	0.5	BN 132MA	M4LA	–	8.7	4.6	
BN 80B	M 2SA	1.3	0.9	0.7	BN 132MB	M4LB	–	11.0	6.5	
BN 90S	M2SB	–	1.3	0.9	BN 160MR	M4LC	12.5	12.5	–	
BN 90SA		1.8	–	–	BN 160MB	M5SB	17.5	–	–	
BN 90L	M3SA	2.5	–	1.3	BN 160M	M5SA	–	–	8.6	
BN 90LA		–	1.8	–	BN 160L	M5S	21.5	17.5	12.6	
BN 100L	M3LA	3.5	–	–	BN 180M	M5LA	24.5	21.5	–	
BN 100LA		–	2.5	1.8	BN 180L	–	–	25.3	17.5	
BN 100LB	M3LB	4.7	3.5	2.2	BN 200L	–	34.0	34.0	22.0	

BX / MX sind nur für 50 Hz verfügbar.

BE / ME sind nur in der 4poligen Ausführung für 60 Hz verfügbar. Die Leistungsdaten entsprechen der 50 Hz Ausführung.

Bei polumschaltbare BN / M Motoren, die bei 60 Hz betrieben werden, kommt es zur Erhöhung der Nennleistung in Bezug auf die 50 Hz Werte um ca. 15%. BE/ME Motoren sind nicht als polumschaltbare Varianten verfügbar.

Wenn die Nenndaten für 60 Hz Betrieb, vergleichbar mit den Nenndaten bei 50 Hz, auf dem Motortypenschild aufgeführt werden sollen, dann kann die Option PN gewählt werden.

Die Motoren sind normalerweise für den Betrieb bei 50 Hz ausgelegt, können aber auch unter Berücksichtigung der folgenden Tabelle bei 60 Hz betrieben werden.

(F16)

	50 Hz	60 Hz			
	V - 50 Hz	V - 60 Hz	P _n - 60 Hz	M _n , M _a /M _n - 60 Hz	n [min ⁻¹] - 60 Hz
BE/ME	230/400 Δ/Y	265 - 460 Δ Y	1	0.83	1.2
	400/690 Δ/Y	460 Δ			
BN/M	230/400 Δ/Y	220 - 240 Δ	1.15	1	1.2
	400/690 Δ/Y	380 - 415 Y			
BN/M	230/400 Δ/Y	265 - 280 Δ	1.15	1	1.2
	400/690 Δ/Y	440 - 480 Y			
		440 - 480 Δ			



M6.3 Umgebungstemperatur

Die im Katalog enthaltenen Tabellen geben die technischen Daten bei einer Frequenz von 50 Hz und normalen Umgebungsbedingungen gemäß den Normen CEI EN 60034-1 an (Temperatur 40 °C und Höhe ≤ 1000 m ü. d. M.).

Die Motoren können bei höheren Temperaturen zwischen 40 °C und 60 °C betrieben werden, wenn man die in der nachfolgenden Tabelle angegebenen Reduktionsangaben berücksichtigt.

(F17)

Umgebungstemperatur (°C)	40°	45°	50°	55°	60°
Zulässige Leistung in % der Nennleistung	100%	95%	90%	85%	80%

Bei Reduktionsfaktoren höher als 15 %, bitten wir um Rücksprache.

M6.4 Auf 50 HZ genormte Leistung

PN

Diese Option ermöglicht es auf dem Typenschild des Motors den Wert der auf 50 Hz genormten Leistung angeben zu können, auch wenn eine Spannungsversorgung bei 60 Hz erfolgt. Die Option PN ist immer dabei mit 60 Hz und Spannungsversorgung 230/460V und 575V 60 Hz.

M6.5 Motoren für die USA und Kanada

CUS

Die BN-Motoren sind in der Ausführung NEMA, Design C erhältlich (hinsichtlich der elektrischen Eigenschaften); zertifiziert nach den Normen CSA (Canadian Standard) C22.2 Nr 100 und UL (Underwriters Laboratory) UL 1004-1. Bei Bestellung der Option CUS wird das Typenschild mit den nachstehend aufgeführten Symbolen gekennzeichnet:
CUS Option steht nicht für IE3 Motoren zur Verfügung.



Die Spannungen der amerikanischen Verteilernetze und die entsprechenden Nennspannungen, die bei der Bestellung der Motore angegeben werden müssen, können der folgenden Tabelle entnommen werden:

(F18)

Frequenz	Netzspannung	V _{mot}
60 Hz	208 V	200 V
	240 V	230 V
	480 V	460 V
	600 V	575 V

CUS Option steht nur bei 50 HZ Betrieb zur Verfügung.



Motoren mit YY/Y-Anschluss (z.B. 230/460V-60Hz; 220/440V-60Hz) haben standardmäßig ein 9-poliges Klemmbrett. Bei vergleichbaren Ausführungen entspricht die Nennleistung der des 50 Hz Motors. Das gilt ebenso für 575 V - 60 Hz Motoren. Für Bremsmotoren mit Gleichstrombremse vom Typ BN_FD und BN_AFD erfolgt die Versorgung des Gleichrichters über das Motorklemmbrett mit einer Spannung von 230 V (einphasiger Wechselstrom). Bei Bremsmotoren stellt sich die Versorgung der Bremse wie folgt dar:

(F19)

BN_FD ; BN_AFD M_FD ; M_AFD	BN_FA M_FA	Bitte angeben
Vom Motorklemmenkasten 1~230V c.a.	Fremdversorgung 230V Δ - 60Hz	230SA
	Fremdversorgung 460V Y - 60Hz	460SA

Die CUS-Option ist für die Fremdlüftermotoren oder die mit AFD-Bremse ausgestatteten Motoren nicht anwendbar.

M6.6 China Compulsory Certification

CCC

Die für den Vertrieb in der Volksrepublik China vorgesehenen Elektromotoren fallen unter den Geltungsbereich des Zertifizierungssystems CCC (China Compulsory Certification). Die Motoren der Serie BN mit Nenndrehmoment bis 7 Nm sind mit CCC-Zertifizierung und Sondertypenschild mit der unten dargestellten Kennzeichnung erhältlich:



Die CCC-Option ist für die mit AFD-Bremse ausgestatteten Motoren nicht anwendbar.
 CCC Option ist nicht für IE3 Motoren verfügbar.
 CCC Option ist nicht für Motoren mit Fremdlüftung verfügbar.

M6.7 Isolationsklasse

CL F

Die Motoren von Bonfiglioli sind serienmäßig mit Isolierstoffen (Emaildraht, Isolierstoffen, Imprägnierharzen) der Klasse **F** ausgestattet.

Allgemein bleiben die Motoren in der Standardausführung innerhalb des Grenzwertes von 80K, der einer Übertemperatur der Klasse B entspricht.

Die sorgfältige Auswahl der Komponenten des Isoliersystem gestatten den Einsatz dieser Motoren auch unter tropischen Klimabedingungen und bei Vorliegen normaler Vibrationen.

Für den Einsatz in in der Nähe aggressiv wirkender chemischer Substanzen oder bei hoher Luftfeuchtigkeit wird empfohlen, sich zur Wahl eines passendes Produktes mit unserem Technischen Kundendienst in Verbindung zu setzen.



CL H

Auf Anfrage können sie auch in der Klasse **H** geliefert werden.
 Nicht verfügbar für die mit den CSA- und UL-Normen konformen Motoren (CUS-Option).

(F20)

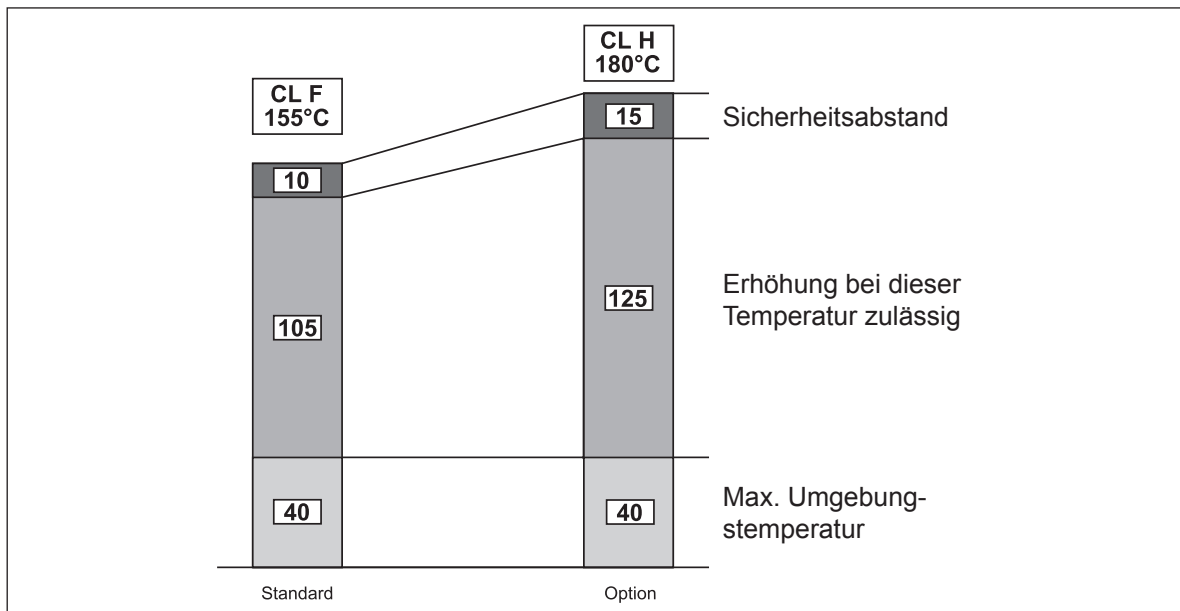

M6.8 Betriebsart

Sofern nicht anderweitig angegeben, beziehen sich die im Katalog angegebene Motorleistungen auf den Dauerbetrieb S1. Bei Motoren, die unter Bedingungen eingesetzt werden, die nicht mit S1 übereinstimmen, muss die entsprechende Betriebsart unter Bezugnahme auf die Normen CEI EN 60034-1 festgelegt werden. Insbesondere kann man, für die Betriebsarten S2 und S3, durch Anwendung der in der nachstehenden Tabelle angeführten Koeffizienten der für den Dauerbetrieb vorgesehenen Leistung gegenüber eine Leistungssteigerung erzielen. Diese Tabelle gilt für einpolige Motoren.

Alternativ zum Dauerbetrieb S1 kann in der Konfigurationsphase des Produkts eine der folgenden Betriebsarten gewählt werden: S2, S3 oder S9. Auf dem Typenschild des Motors werden die erhöhte Leistung entsprechend der Betriebsart, die diesbezüglichen elektrischen Daten und als Betriebsart entweder S2-30min, S3-70% oder S9 angegeben.

Für weitere Details bitte den technischen Kundendienst von Bonfiglioli kontaktieren.

Für die polumschaltbaren Motoren sollte man sich im Hinblick auf den Leistungssteigerung, mit unserem Technischen Kundendienst in Verbindung setzen.

(F21)

	Betriebsart						
	S2			S3 *			S4 - S9 Setzen Sie sich mit uns in Verbindung
	10	30 (*)	60	25%	40%	70% (*)	
f_m	1.35	1.15	1.05	1.25	1.15	1.1	

* Die Zyklusdauer muß in jedem Fall kleiner oder gleich 10 Minuten sein. Wenn sie darüber liegt, bitte Rücksprache mit unserem Technischen Kundendienst.

(*) Standardwert der Optionen (Tab. F05).



M6.8.1 Relative Einschaltdauer:

$$I = \frac{t_f}{t_f + t_r} \cdot 100 \quad (01)$$

t_f = Betriebszeit mit konstanter Last

t_r = Aussetzzeit

M6.8.2 Kurzzeitbetrieb S2

Betrieb mit konstanter Last für eine begrenzte Zeit, die unter der Zeit liegt, die zum Erreichen des thermischen Beharrungszustands benötigt wird, gefolgt von einer Pause, die so lang ist, dass der Motor nahezu wieder auf die Umgebungstemperatur abkühlen kann.

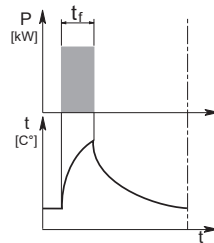

M6.8.3 Aussetzbetrieb S3:

Betrieb mit aufeinanderfolgenden, identischen Betriebszyklen, die alle einen Zeitraum mit konstanter Belastung und einer Pause beinhalten.

Bei dieser Betriebsart beeinflusst der Anlaufstrom die Übertemperatur nicht merklich.

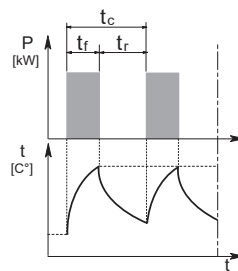

M6.9 Frequenzumrichterbetrieb

Die Elektromotoren Bonfiglioli können über PWM Frequenzumrichter bis 500 V Nennspannung am Umrichtereingang versorgt werden. Bei den Serienmotoren wird ein Phasenisolierungssystem mittels Wicklungstrenner, Emaildraht der Klasse 2 und Imprägnierharze der Klasse H eingesetzt (widerstandsfähig bei Spannungsimpulsen bis 1600 V Spitze-Spitze und Anstiegszeiten $t_s > 0.1 \mu s$ an den Motorklemmen). Die typischen Merkmale von Drehmoment/Geschwindigkeit im Betrieb S1 für Motoren mit einer Grundfrequenz $f_b = 50$ Hz werden in der nachstehenden Tabelle, verfügbar. Bei Betriebsfrequenzen unter ungefähr 30 Hz müssen die eigenbelüftenden Standardmotoren (IC411) aufgrund der in diesem Fall abnehmenden Kühlung entsprechend drehmomentreduziert oder, alternativ, fremdbelüftet betrieben werden. Bei über der Grundfrequenz liegenden Drehzahlen arbeitet der Motor nach Erreichen des max. Spannungswerts am Umrichter Ausgang in einem Feldschwächbereich mit konstanter Leistung mit einem reduziertem Drehmoment, welches ungefähr im Verhältnis (f/f_b) abnimmt. Da das Kippmoment des Motors ungefähr mit dem Faktor $(f/f_b)^2$ abnimmt, muss auch der zulässige Überlastungsgrenzwert entsprechend reduziert werden.



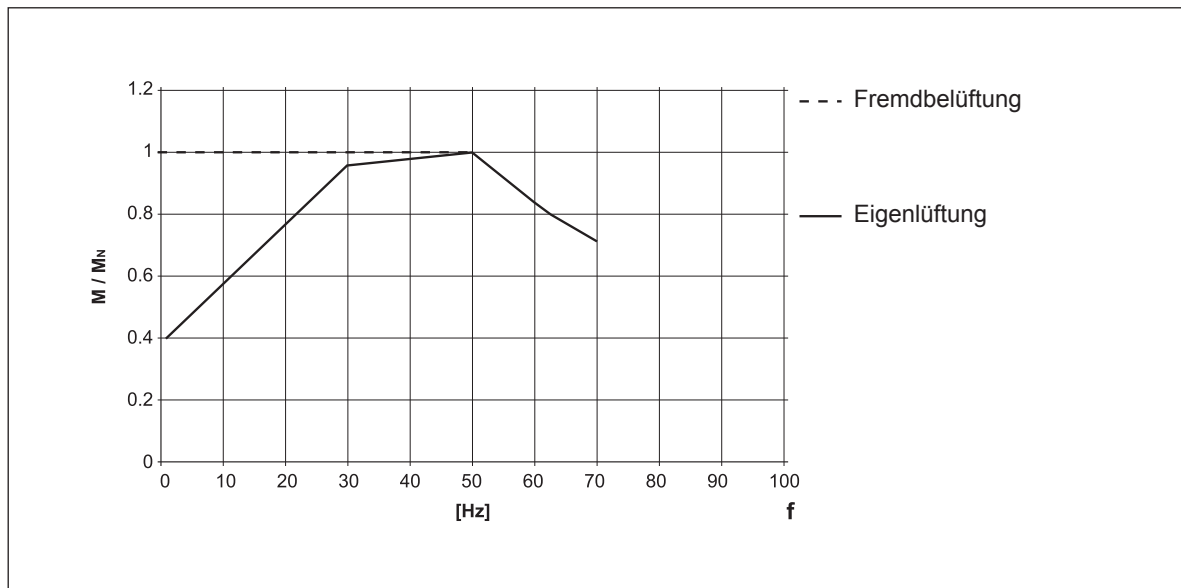

(F22)



Für Anwendungen, bei denen der Motor oberhalb der Eckfrequenz betrieben wird, finden sie die mechanische Drehzahlgrenzen in der folgenden Tabelle:

(F23)

		n [min ⁻¹]		
		2p	4p	6p
				
≤ BE 112 - BN 112	ME2 - ME3 M05 ... M3	5200	4000	3000
BX 132 ... BX 180	MX4 MX5		4000	
BE 132 ... BE 180	ME4 ME5	4500	4000	3000
BN 132 ... BN 200L	M4 M5	4500	4000	3000

Bei Drehzahlen oberhalb der Nennwerte, treten stärkere mechanische Schwingungen und höhere Lüftergeräusche auf. Bei diesen Anwendungen wird ein Auswuchten des Rotors im Grad B und eventuell der Einsatz eines Fremdlüfters empfohlen.

Der Fremdlüfter und, falls vorhanden, die elektromagnetische Bremse müssen immer direkt über das Netz gespeist werden.

M6.10 Maximale Schaltungshäufigkeit Z

In den Datentabellen der Motoren ist für den jeweiligen Bremsentyp die maximale Schaltungshäufigkeit im Leerlauf Z₀ bei relativer Einschaltdauer I = 50% angegeben. Dieser Wert definiert die maximale Anzahl von Anläufen im Leerlauf pro Stunde, ohne dass die maximal zulässige Wicklungstemperatur der Isolierstoffklasse F überschritten wird.

Wenn in der realen Anwendung beispielsweise ein Motor eine Last mit dem Massenträgheitsmoment J_c mit einem mittleren Anlauf-Lastmoment M_L antreibt und dabei die Leistung P_r benötigt, kann die max. zulässige Schaltheufigkeit mit folgender Formel überschlägig berechnet werden:



$$Z = \frac{Z_0 \cdot K_c \cdot K_d}{K_J} \quad (02)$$

wo:

$$K_J = \frac{J_m + J_c}{J_m} \quad \text{Massenträgheitsfaktor}$$

$$K_c = \frac{M_a - M_L}{M_a} \quad \text{Drehmomentfaktor}$$

$$K_d = \quad \text{Lastfaktor, siehe folgende Tabelle}$$

(F24)

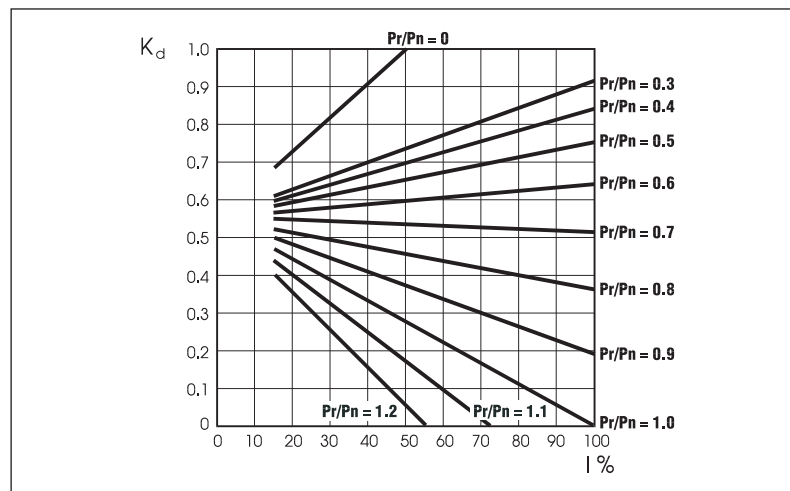

Auf Grundlage der berechneten Schaltspiele muss anschließend anhand der Tabellen (F31), (F41) und (F49) überprüft werden, ob die geforderte Bremsarbeit die Wärmegrenzleistung der Bremse W_{max} nicht überschreitet.



M7 DREHSTROMBREMSMOTOREN

M7.1 Betriebsweise

Die Bremsmotoren sind mit Federdruckbremsen ausgestattet, die mit Gleichstrom (Typ FD, AFD) oder mit Drehstrom (Typ FA) gespeist werden.

Alle Bremsen arbeiten gemäß dem sicheren Ruhestromprinzip, d.h. sie fallen bei Stromausfall über Federdruck ein.

(F25)

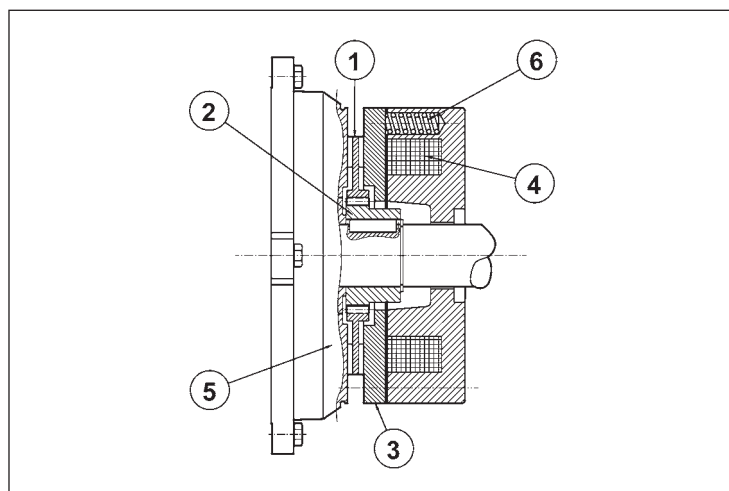

Zeichenerklärung:

- ① Bremsscheibe
- ② Nabe
- ③ Beweglicher Anker
- ④ Ringspule
- ⑤ Motorschild
- ⑥ Sprungfedern

Wenn die Spannungsversorgung unterbrochen wird, schieben Druckfedern den beweglichen Anker gegen die Bremsscheibe. Die Bremsscheibe wird zwischen der Ankerfläche und dem Motorschild gepresst und blockiert damit den Rotor. Wird die Spule erregt, wird der Anker durch das Magnetfeld gegen die Federkraft bewegt und die Bremsscheibe und damit auch der Rotor werden wieder frei gegeben.

M7.2 Allgemeine Eigenschaften

- Hohe und einstellbare Bremsmomente (allgemein $M_b \approx 2 M_n$).
- Bremsscheibe mit Stahlkern und doppeltem Bremsbelag (Material mit geringem Verschleiß, asbestfrei).
- Sechskant hinten an der Motorwelle, auf Lüfterradseite (N.D.E.), für eine manuelle.
- Drehung des Rotors mit einem Inbusschlüssel (nicht lieferbar, wenn die Optionen PS, RC, TC, U1, U2, EN1, EN2, EN3, EN4, EN5, EN6) bestellt werden.
- Manuell zu betätigende, mechanische Bremslüftvorrichtung (Optionen R und RM für BN_FD; Optionen R für BN_FA).
- Manuell zu betätigende, mechanische Bremslüftvorrichtung (Option R für BN_AFD).
- Korrosionsschutzbehandlung an allen Flächen der Bremse.
- Isolierstoffklasse in Klasse F.



M8 DREHSTROMBREMSMOTOREN MIT GLEICHTROMBREMSE: TYP BN_FD und M_FD

Baugrößen: BN 63 ... BN 200L / M05 ... M5

(F26)

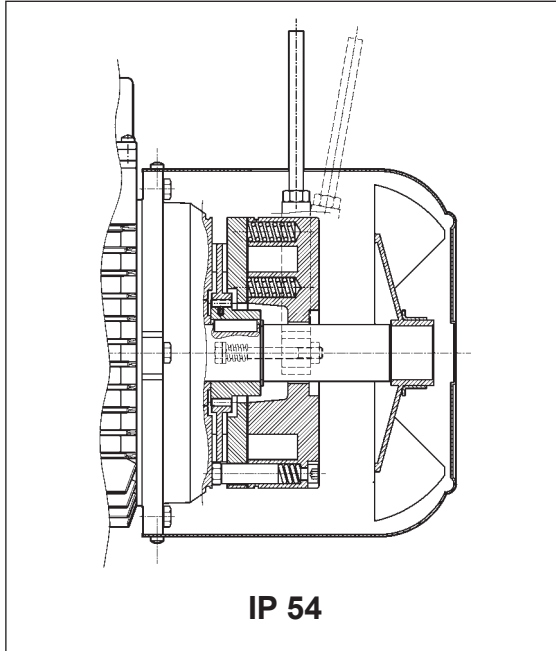

(F27)

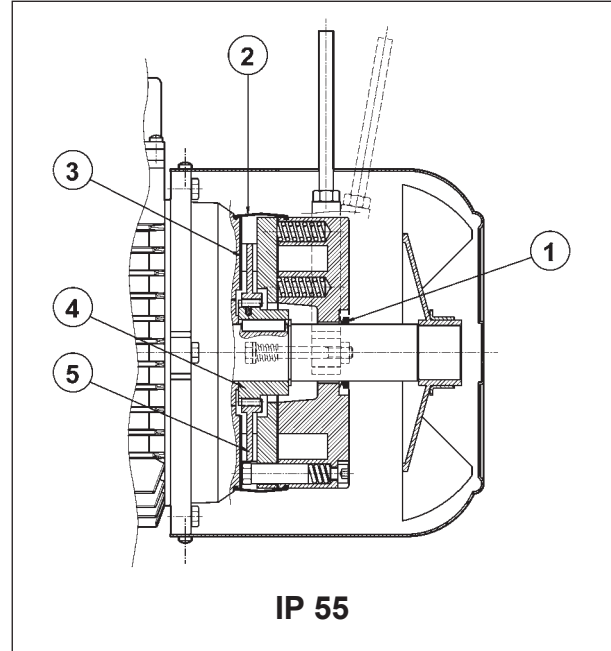

Elektromagnetische Bremse mit Ringwicklungsspule für **Gleichstromspannung**, die mittels Schrauben am hinteren Motorschild befestigt ist. Die Federn sorgen für die axiale Ausrichtung des Magnetkörpers. Die Bremscheibe gleitet auf der Mitnehmernabe aus Stahl; die Nabe ist an der Welle aufgezogen und mit Schwingungsdämpfung versehen. Die Motoren werden vom Hersteller auf das in der Tabelle der technischen Daten angegebenen Bremsmoment eingestellt. Das Bremsmoment kann durch das Ändern des Typs und/oder der Anzahl der Federn eingestellt werden. Auf Anfrage können die Motoren mit einem Bremslüfthebel für die manuelle Lüftung der Bremse mit selbsttätiger Rückstellung (**R**) ohne Arretierung oder mit arretierbarem Lüfthebel (**RM**) geliefert werden. Die Festlegung der möglichen Positionen des Bremslüfthebels in Abhängigkeit von der Klemmkastenlage erfolgt durch die Optionsbeschreibung im Abschnitt "BREMSLÜFTHEBEL".

Die Bremse vom Typ FD garantiert hohe dynamische Leistungen und niedrige Laufgeräusche. Die Ansprechigenschaften der Bremse unter Gleichstrom können je nach Bedarfsfall durch den Einsatz der verschiedenen verfügbaren Gleichrichter oder durch einen entsprechenden Bremsenanschluss optimiert werden.

Für Anwendungen, bei denen Hubvorgänge und/oder hohe Werte stündlich anfallender Arbeit vorgesehen sind, bitte den technischen Kunden-/Vertriebsdienst kontaktieren.

M8.1 Schutzart

Die Standardausführung ist Schutzart IP54 vor. Optional kann der Bremsmotor vom Typ FD in der Schutzart **IP55** geliefert werden, wobei sind folgende Komponenten eingesetzt werden:

- ① V-Ring an der Motorwelle N.D.E.
- ② Schutzring aus Gummi
- ③ Ring aus rostfreiem Stahl zwischen Motorschild und Bremscheibe
- ④ Mitnehmernabe aus rostfreiem Stahl
- ⑤ Bremscheibe aus rostfreiem Stahl



M8.2 Spannungsversorgung der Bremse FD

Die Versorgung der Gleichstrombremsspule erfolgt über einen Gleichrichter im Klemmkasten, der, falls nichts anderes angegeben ist, werkseitig mit der Bremsspule verdrahtet ist.

Bei den einpoligen Motoren ist serienmäßig der Anschluss des Gleichrichters an das Motorklemmbrett vorgesehen. Unabhängig von der Netzfrequenz erfolgt die Versorgung des Gleichrichters VB über die in der nachstehenden Tabelle angegebenen Standardspannungen:

(F28)

2, 4, 6 P				1 speed	
		BN_FD / M_FD		Bremsenversorgung über die Motorspannung	Separate Versorgung
		$V_{mot} \pm 10\%$ 3 ~	$V_B \pm 10\%$ 1 ~		
BN 63...BN 132	M05...M4LB	230/400 V – 50 Hz	230 V	standard	angeben $V_B SA$ o $V_B SD$
BN 160...BN 200	M4LC...M5	400/690 V – 50 Hz	400 V	standard	angeben $V_B SA$ o $V_B SD$

Die polumschaltbaren Motoren müssen immer mit separater Bremsenversorgungsspannung betrieben werden, deshalb erfolgt die Lieferung standardmäßig ohne Anschluss der Bremse an das Motorklemmbrett. Die Versorgungsspannung des Gleichrichters V_B wird in der nachstehenden Tabelle angegeben:

(F29)

2/4, 2/6, 2/8, 2/12, 4/6, 4/8 P				2 speed	
		BN_FD / M_FD		Bremsenversorgung über die Motorspannung	Separate Versorgung
		$V_{mot} \pm 10\%$ 3 ~	$V_B \pm 10\%$ 1 ~		
BN 63...BN 132	M05...M4LB	400 V – 50 Hz	230 V		angeben $V_B SA$ o $V_B SD$

Bei dem Gleichrichter handelt es sich um einen Typ mit Einwegschaltung (VDC \approx 0,45 VAC). Er ist in den Versionen **NB**, **SB**, **NBR** und **SBR**, gemäß den Details in der nachstehenden Tabelle, verfügbar:

(F30)

		Bremse		standard		auf Anfrage						
BN 63	M05	FD 02				SB						
BN 71	M1	FD 03				NB	SBR					
		FD 53					NBR					
BN 80	M2	FD 04							SBR			
BN 90S	—	FD 14							SB	SBR		
BN 90L	—	FD 05										
BN 100	M3	FD 15										NBR
—		FD 55										SB
BN 112	—	FD 06S										
BN 132...160MR	M4	FD 56										
BN 160L - BN 180M	M5	FD 06										
BN 180L - NM 200L	—	FD 07										

(*) $t_{2c} < t_{2r} < t_2$



Der Gleichrichter **SB** mit elektronischer Kontrolle der Erregung reduziert die Bremslützeiten, indem er die Bremsspule im Einschaltmoment übermäßig stark erregt, um dann, nach erfolgtem Lüftvorgang, in die normale Gleichrichterschaltung umzuschalten.

Der Einsatz des Gleichrichtertyps **SB** wird bei folgenden Einsatzfällen empfohlen:

- hohe Schalzhäufigkeit
- kurze Bremslützeiten
- starke thermische Beanspruchung der Bremse

Für die Anwendungen mit schnellen Bremsenreaktionszeiten (Öffnungszeit der Bremse), können auf Anfrage die Gleichrichter **NBR** oder **SBR** geliefert werden.

Diese Gleichrichter erweitern die Funktion der Typen **NB** und **SB**, indem bei Spannungsunterbrechung ein elektronischer Schaltkreis einen Kontakt öffnet und dadurch die Magnetspule schnell entregt wird. Diese Lösung ermöglicht eine Verkürzung der Bremsansprechzeiten ohne zusätzlichen Schaltungsaufwand.

Bestmögliche Performance wird bei den Gleichrichtern **NBR** und **SBR** mit einer separaten Versorgungsspannung erreicht.

Verfügbare Spannungen: 230VAC ±10%, 400VAC ± 10%, 50/60 Hz (mit Gleichrichter); 100VDC ±10%, 180VDC ± 10% (mit Option SD).

M8.3 Technische Daten - Bremsentyp FD

In der nachstehenden Tabelle werden die technischen Daten der Gleichstrombremsen vom Typ FD angegeben.

(F31)

Bremsen	Bremsmoment M_b [Nm]			Ansprechzeit		Bremsvorgang		W_{max} pro Bremsvorgang			W [MJ]	P [W]
	feder			t_1	t_{1s}	t_2	t_{2c}	[J]				
	6	4	2	[ms]	[ms]	[ms]	[ms]	10 s/h	100 s/h	1000 s/h		
FD02	–	3.5	1.75	30	15	80	9	4500	1400	180	15	17
FD03	5	3.5	1.75	50	20	100	12	7000	1900	230	25	24
FD53	7.5	5	2.5	60	30	100	12					
FD04	15	10	5	80	35	140	15	10000	3100	350	30	33
FD14												
FD05	40	26	13	130	65	170	20	18000	4500	500	50	45
FD15	40	26	13	130	65	170	20					
FD55	55	37	18	–	65	170	20					
FD06S	60	40	20	–	80	220	25	20000	4800	550	70	55
FD56	–	75	37	–	90	250	20	29000	7400	800	80	65
FD06		100	50		100	250	20					
FD07	150	100	50	–	120	200	25	40000	9300	1000	130	65
FD08*	250	200	170	–	140	350	30	60000	14000	1500	230	100
FD09**	400	300	200	–	200	450	40	70000	15000	1700	230	120

* erreichte Bremsmomentwerte, die durch den Einsatz von jeweils 9, 7, 6 Federn erreicht werden

** Werte, die durch den Einsatz von jeweils 12, 9, 6 Federn erreichten Bremsmomente

- t_1 = Ansprechzeit der Bremse mit Einweggleichrichter
- t_{1s} = Ansprechzeit der Bremse mit elektronisch gesteuertem Gleichrichter
- t_2 = Bremsverzögerung mit Unterbrechung auf Wechselstromseite und Fremdversorgung
- t_{2c} = Bremsverzögerung mit Unterbrechung auf Wechselstrom- und Gleichstromseite – Die in der Tab. (F30) angegebenen Werte t_1 , t_{1s} , t_2 , t_{2c} beziehen sich auf eine Bremse mit eingestelltem max. Bremsmoment, mit mittlerem Luftspalt und bei Nennspannung
- W_{max} = max. Energie pro Bremsvorgang
- W = Bremsenergie zwischen zwei Einstellungen des Luftspalts
- P_b = bei 20° C von der Bremse aufgenommene Leistung (50 Hz)
- M_b = statisches Bremsmoment (±15%)
- s/h = Schaltspiele pro Stunde



Der Verschleiß der Reibdichtungen ist von den Betriebsbedingungen abhängig (Temperatur, Feuchtigkeit, Schlupfgeschwindigkeit, spezifischer Druck); die Verschleißangaben sind demnach als Richtwerte zu betrachten.

M8.4 Anschlüsse - Bremsentyp FD

Die einpoligen Motoren werden mit werkseitig an das Motorklemmbrett angeschlossenen Gleichrichtern geliefert. Bei den polumschaltbaren Motoren und bei Bremsen mit separater Versorgung werden die Gleichrichter kundenseitig mit einer auf dem Typenschild angegebenen Bremsenspannung VB angeschossen.

Da es sich bei der Bremsspule um eine induktive Last handelt, müssen gemäß IEC 60947-4-1 für die Ansteuerung der Bremse und die Unterbrechung der Gleichstromseite Kontakte der Kategorie AC-3 verwendet werden.

Tabelle (F32) – Bremsenversorgung über die Motorspannung und netzseitige Unterbrechung. Verzögerter und von den Zeitkonstanten des Motors abhängige Haltezeit t_2 . Vorzusehen, wenn möglichst ruckfreie Starts/Stops gefordert sind.

Tabelle (F33) – Bremsspule mit separater Spannungsversorgung und Unterbrechung der Wechselstromseite. Normale und vom Motor unabhängige Stoppszeiten. Es werden die in der Tabelle (F31) angegebenen Stoppszeiten t_2 realisiert.

Tabelle (F34) – Bremsspule mit Versorgung über die Motorspannung und Unterbrechung der Gleich- und der Motorspannung. Schneller Stopp mit den in der Tabelle (F31) angegebenen Ansprechzeiten t_{2c} .

Tabelle (F35) – Bremsspule mit separater Spannungsversorgung und Unterbrechung der Gleich- und der Wechselstromseite.

Reduzierte Stoppszeiten mit den in der Tabelle (F31) angegebenen Werten t_{2c} .

Die Bremsspannungsversorgung über die Motorspannung (von Tab. F32 bis Tab. F35) darf nur erfolgen wenn die Nennspannung der Bremse der geringeren Nennspannung des Motors entspricht.

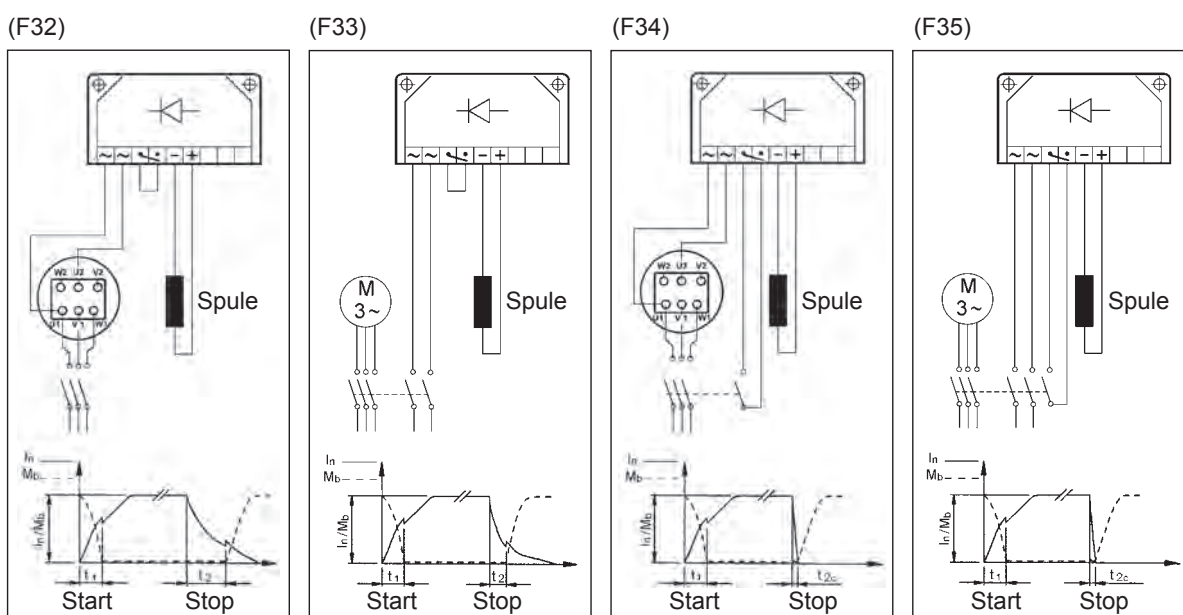



M9 DREHSTROMBREMSMOTOREN MIT GLEICHTROMBREMSE: TYP BN_AFD und M_AFD

Baugrößen: BN 63 ... BN 200L / M05 ... M5

(F36)

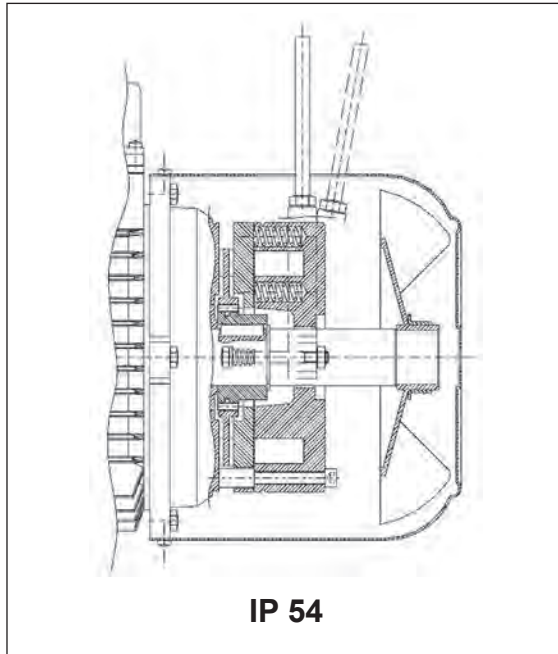

IP 54

(F37)

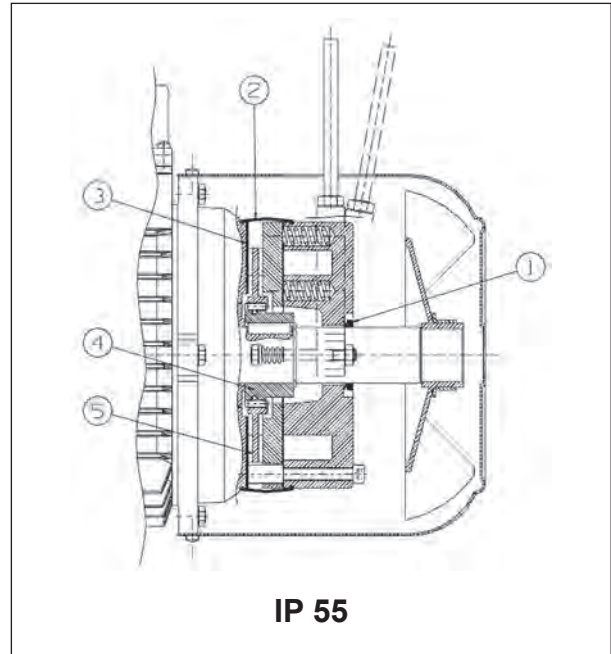

IP 55

Bremse mit festem Luftspalt, wartungsfrei bis zum maximal zulässigen Verschleiß der Reibdichtung. Der Luftspalt ist voreingestellt und darf nicht geändert werden.

Elektromagnetische Bremse mit Ringwicklungsspule für **Gleichstromspannung**, die mittels Schrauben am hinteren Motorschild befestigt ist. Die Bremsscheibe gleitet auf der Mitnehmernabe aus Stahl; die Nabe ist an der Welle aufgezogen und mit Schwingungsdämpfung versehen. Die Motoren werden vom Hersteller auf den in der Tabelle der technischen Daten angegebenen Bremsmoment eingestellt; das Bremsmoment kann durch das Ändern des Typs und/oder der Anzahl der Federn reguliert werden. Auf Anfrage können die Motoren mit einem Bremslüfthebel für die manuelle Lüftung der Bremse mit selbsttätiger Rückstellung (**R**) geliefert werden. Die Festlegung der möglichen Positionen des Bremslüfthebels in Abhängigkeit von der Klemmkastenlage erfolgt durch die Optionsbeschreibung im Abschnitt "BREMSLÜFTHEBEL".

Die Bremse vom Typ AFD garantiert hohe dynamische Leistungen und niedrige Laufgeräusche. Die Ansprechereigenschaften der Bremse unter Gleichstrom können in Abhängigkeit zur jeweiligen Anwendung durch den Einsatz der verschiedenen verfügbaren Gleichrichter oder durch eine entsprechenden Anschluß der Bremse optimiert werden. Die AFD-Bremse empfiehlt sich für Anwendungen, bei denen sie als Feststellbremse eingesetzt wird.

Für Anwendungen, bei denen Hubvorgänge und/oder hohe Werte stündlich anfallender Arbeit vorgesehen sind, bitte den technischen Kunden-/Vertriebsdienst kontaktieren.

M9.1 Schutzart

Die Standardausführung ist Schutzart IP54 vor. Optional kann der Bremsmotor vom Typ AFD in der Schutzart **IP55** geliefert werden, wobei sind folgende Komponenten eingesetzt werden:

- ① V-Ring an der Motorwelle N.D.E.
- ② Schutzring aus Gummi
- ③ Ring aus rostfreiem Stahl zwischen Motorschild und Bremsscheibe
- ④ Mitnehmernabe aus rostfreiem Stahl
- ⑤ Bremsscheibe aus rostfreiem Stahl





M9.2 Spannungsversorgung der Bremse AFD

Die Versorgung der Gleichstrombremsspule erfolgt über einen Gleichrichter im Klemmkasten, der, falls nichts anderes angegeben ist, werkseitig mit der Bremsspule verdrahtet ist.

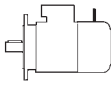

Bei den einpoligen Motoren ist serienmäßig der Anschluss des Gleichrichters an das Motorklemmbrett vorgesehen. Unabhängig von der Netzfrequenz erfolgt die Versorgung des Gleichrichters VB über die in der nachstehenden Tabelle angegebenen Standardspannungen:

(F38)

2, 4, 6 P				1 speed	
		BN_AFD / M_AFD		Bremsenversorgung über die Motorspannung	Separate Versorgung
		$V_{mot} \pm 10\%$ 3 ~	$V_B \pm 10\%$ 1 ~		
BN 63...BN 132	M05...M4LB	230/400 V – 50 Hz	230 V	standard	angeben V_B SA o V_B SD
BN 160MR	M4LC	400/690 V – 50 Hz	400 V	standard	angeben V_B SA o V_B SD

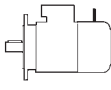

Die polumschaltbaren Motoren müssen immer mit separater Bremsenversorgungsspannung betrieben werden, deshalb erfolgt die Lieferung standardmäßig ohne Anschluss der Bremse an das Motorklemmbrett. Die Versorgungsspannung des Gleichrichters V_B wird in der nachstehenden Tabelle angegeben:

(F39)

2/4, 2/6, 2/8, 2/12, 4/6, 4/8 P				2 speed	
		BN_AFD / M_AFD		Bremsenversorgung über die Motorspannung	Separate Versorgung
		$V_{mot} \pm 10\%$ 3 ~	$V_B \pm 10\%$ 1 ~		
BN 63...BN 132	M05...M4LB	400 V – 50 Hz	230 V	⊖	angeben V_B SA o V_B SD

Bei dem Gleichrichter handelt es sich um einen Typ mit Einwegschaltung (VDC \approx 0,45 VAC). Er ist in den Versionen **SB** und **SBR**, gemäß den Details in der nachstehenden Tabelle, verfügbar:

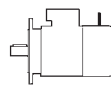
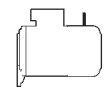
(F40)

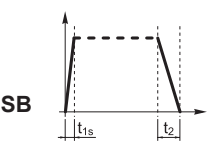
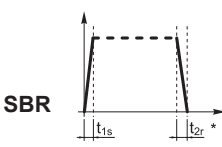
		Bremse	standard	 auf Anfrage
BN 63	M05	AFD 02		
BN 71	M1	AFD 03		
BN 80	M2	AFD 04		
BN 90S	—	AFD 14		
BN 90L	—	AFD 05		
BN 100	M3	AFD 15		
BN 112	—	AFD 06S		
BN 132...160MR	M4	AFD 06		
		AFD 07		

(*) $t_{2c} < t_{2r} < t_2$



Der Gleichrichter **SB** mit elektronischer Kontrolle der Erregung reduziert die Bremsluftzeiten, indem er die Bremsspule im Einschaltmoment ubermasig stark erregt, um dann, nach erfolgtem Luftvorgang, in die normale Gleichrichterschaltung umzuschalten.

Der Einsatz des Gleichrichtertyps **SB** wird bei folgenden Einsatzfallen empfohlen:

- hohe Schalthufigkeit
- kurze Bremsluftzeiten
- starke thermische Beanspruchung der Bremse

Fur die Anwendungen mit schnellen Bremsenreaktionszeiten (ffnungszeit der Bremse) , konnen auf Anfrage die Gleichrichter **SBR** geliefert werden.

Diese Gleichrichter erweitern die Funktion der Typen **SB**, indem bei Spannungsunterbrechung ein elektronischer Schaltkreis einen Kontakt ffnet und dadurch die Magnetspule schnell entregt wird. Diese Losung ermoglicht eine Verkurzung der Bremsansprechzeiten ohne zusatzlichen Schaltungsaufwand. Bestmogliche Performance wird bei den Gleichrichtern **SBR** mit einer separaten Versorgungsspannung erreicht.

Verfugbare Spannungen: 230 VAC ±10%, 400 VAC ± 10%, 50/60 Hz (mit Gleichrichter); 100 VDC ±10%, 180 VDC ± 10% (mit Option SD).

M9.3 Technische Daten - Bremsentyp AFD

In der nachstehenden Tabelle werden die technischen Daten der Gleichstrombremsen vom Typ AFD angegeben.

(F41)

Bremsen	Bremsmoment M_b [Nm]			Ansprechzeit		Bremsvorgang			W_{max} pro Bremsvorgang			W [MJ]	P [W]
	feder			t_{in} (± 0.1 mm)	t_{max}	t_{1s} [ms]	t_2 [ms]	t_{2c} [ms]	[J]				
	6	4	2						10 s/h	100 s/h	1000 s/h		
AFD 02	—	3.5	1.8	0.3	0.7	20	110	10	4500	1400	160	40	15
AFD 03	7.5	5	2.5	0.3	0.7	35	140	15	7000	1900	210	60	21
AFD 04	15	10	5	0.4	0.8	55	180	15	11000	3100	350	75	27
AFD 14													
AFD 05	40	26	13	0.4	0.8	85	240	25	18000	4500	500	125	37
AFD 15													
AFD 06S	60	40	20	0.45	0.9	110	280	30	25000	6300	700	175	47
AFD 06	100	75(*) / 62(*)	37	0.45	0.9	130	330	30	29000	7400	800	200	50
AFD 07	150	100	50	0.45	0.95	170	350	30	40000	9300	1000	320	55

(*) vom Federtyp abhangig

- t_{in} = Luftspalt mit neuen Bremsscheibe
- t_{max} = maximale Luftspalt, der notwendig ist um die Bremsscheibe zu ersetzen
- t_1 = Ansprechzeit der Bremse mit Einweggleichrichter
- t_{1s} = Ansprechzeit der Bremse mit elektronisch gesteuertem Gleichrichter
- t_2 = Bremsverzogerung mit Unterbrechung auf Wechselstromseite und Fremdversorgung
- t_{2c} = Bremsverzogerung mit Unterbrechung auf Wechselstrom- und Gleichstromseite – Die in der Tabelle angegebenen Werte t_1 , t_{1s} , t_2 , t_{2c} beziehen sich auf eine Bremse mit eingestelltem max. Bremsmoment, mit mittlerem Luftspalt und bei Nennspannung
- W_{max} = max. Energie pro Bremsvorgang
- W = Bremsenergie zwischen zwei Einstellungen des Luftspalts
- P_b = bei 20° C von der Bremse aufgenommene Leistung (50 Hz)
- M_b = statisches Bremsmoment (±15%)
- s/h = Schaltspiele pro Stunde

Der Verschleiß der Reibdichtungen ist von den Betriebsbedingungen abhangig (Temperatur, Feuchtigkeit, Schlupfgeschwindigkeit, spezifischer Druck); die Verschleißangaben sind demnach als Richtwerte zu betrachten.



M9.4 Anschlüsse - Bremsentyp AFD

Die einpoligen Motoren werden mit werkseitig an das Motorklemmbrett angeschlossenen Gleichrichtern geliefert. Bei den polumschaltbaren Motoren und bei Bremsen mit separater Versorgung werden die Gleichrichter kundenseitig mit einer auf dem Typenschild angegebenen Bremsenspannung VB angeschlossen.

Da es sich bei der Bremsspule um eine induktive Last handelt, müssen gemäß IEC 60947-4-1 für die Ansteuerung der Bremse und die Unterbrechung der Gleichstromseite Kontakte der Kategorie AC-3 verwendet werden.

Tabelle (F42) – Bremsenversorgung über die Motorspannung und netzseitige Unterbrechung. Verzögerter und von den Zeitkonstanten des Motors abhängige Haltezeit t_2 . Vorzusehen, wenn möglichst ruckfreie Starts/Stopps gefordert sind.

Tabelle (F43) – Bremsspule mit separater Spannungsversorgung und Unterbrechung der Wechselstromseite. Normale und vom Motor unabhängige Stoppszeiten. Es werden die in der Tabelle (F41) angegebenen Stoppszeiten t_2 realisiert.

Tabelle (F44) – Bremsspule mit Versorgung über die Motorspannung und Unterbrechung der Gleich- und der Motorspannung. Schneller Stopp mit den in der Tabelle (F41) angegebenen Ansprechzeiten t_{2c} .

Tabelle (F45) – Bremsspule mit separater Spannungsversorgung und Unterbrechung der Gleich- und der Wechselstromseite.

Reduzierte Stoppszeiten mit den in der Tabelle (F41) angegebenen Werten t_{2c} .

Die Bremsspannungsversorgung über die Motorspannung (von Tab. F42 bis Tab. F45) darf nur erfolgen wenn die Nennspannung der Bremse der geringeren Nennspannung des Motors entspricht.

(F42)

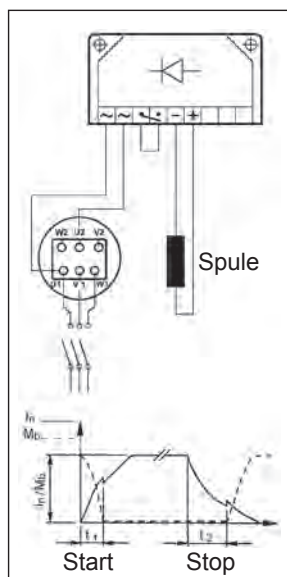

(F43)

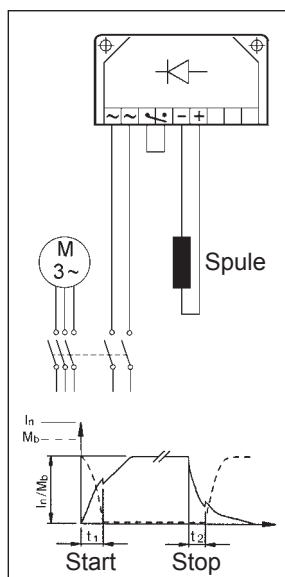

(F44)

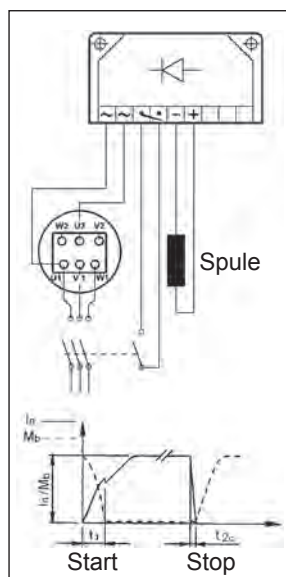

(F45)

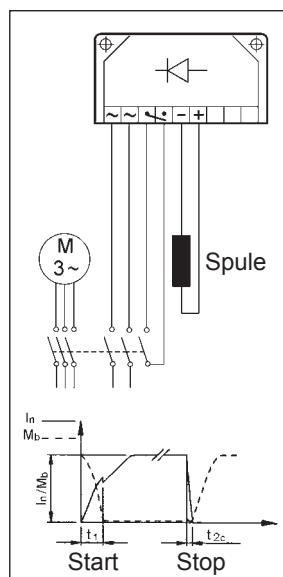



M10 DREHSTROMBREMSMOTOREN MIT DREHSTROMBREMSE: TYP BN_FA und M_FA

Baugrößen: BN 63 ... BN 180M / M05 ... M5

(F46)

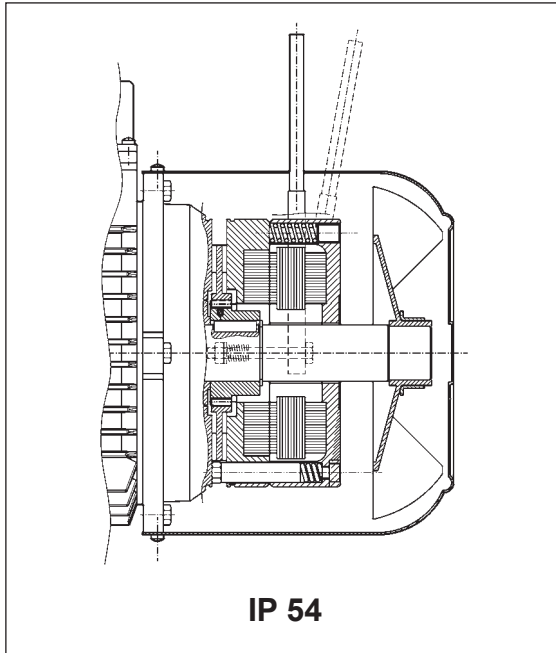

(F47)

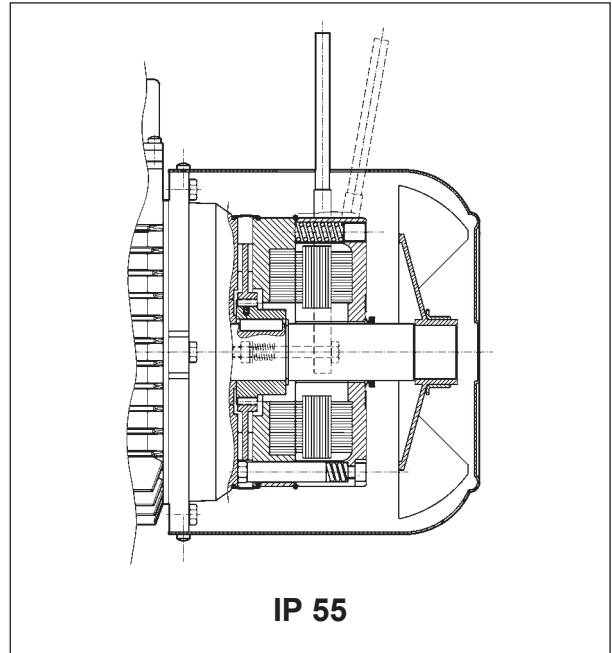

Elektromagnetische Bremse mit Drehstromversorgung, die mittels Schrauben am hinteren Motorschild befestigt ist. Die Federn sorgen dabei für die axiale Ausrichtung des Magnetkörpers. Die Bremsscheibe (Stahl) gleitet axial auf dem sich auf dem Rotor befindlichen Mitnehmer, der über eine Paßfeder mit Motorwelle verbunden und mit Schwingungsdämpfung ist als Bremsmoment wird auf das entsprechende Motormoment eingestellt (siehe Tabelle der technischen Daten der entsprechenden Motoren). Das Bremsmoment ist stufenlos über die Schrauben der Federvorspannung einstellbar. Der Einstellbereich beträgt $30\% Mb_{MAX} < Mb < Mb_{MAX}$ (Mb_{MAX} steht für das in der Tab (F49) angegebene max. Bremsmoment).

Die Bremsen vom Typ FA zeichnen sich durch eine hohe Dynamik aus, weshalb sie für Anwendungen geeignet sind, in denen hohe Schaltfrequenzen und schnelle Ansprechzeiten gefordert werden. Auf Anfrage können die Motoren mit einem Lüfthebel für die manuelle Lüftung der Bremse mit automatischer Rückstellung (R) geliefert werden. Die Festlegung der möglichen Positionen des Bremslüfthebels in Abhängigkeit von der Klemmkastenlage erfolgt durch die Optionsbeschreibung im Abschnitt "BREMSLÜFTHEBEL".

Für Anwendungen, bei denen Hubvorgänge und/oder hohe Werte stündlich anfallender Arbeit vorgesehen sind, bitte den technischen Kunden-/Vertriebsdienst kontaktieren.

M10.1 Schutzart

Die Standardausführung hat Schutzart IP54 vor.

Optional kann der Bremsmotor BN_FA auch in der Schutzart **IP55** geliefert werden, was durch die folgenden zusätzlichen Bauteile erreicht wird:

- V-ring an der Motorwelle N.D.E.
- Schutzring aus Gummi
- O-ring



M10.2 Spannungsversorgung - Bremsentyp FA

Bei den einpoligen Motoren wird die Versorgung der Bremsspule direkt vom Motorklemmbrett abgenommen, das bedeutet, dass die Spannung der Bremse mit der Motorspannung übereinstimmt. In diesem Fall braucht die Bremsenspannung nicht extra angegeben werden.

Bei polumschaltbaren Motoren und bei separater Versorgungsspannung ist ein Hilfsklemmbrett mit 6 Anschlüssen vorgesehen, die einen Anschluss der Bremse ermöglichen. In beiden Fällen muss die Bremsenspannung in der Bestellung angegeben werden.

In der nachstehenden Tabelle werden für die einpoligen und die polumschaltbaren Motoren die Standardspannungen der Wechselstrombremsen angegeben.

(F48)

Einpolige Motoren	BN 63...BN 132	BN 160...BN 180
	230Δ / 400Y V ±10% – 50 Hz	400Δ/ 690Y V ±10% – 50 Hz
	265Δ / 460Y ±10% - 60 Hz	460Y – 60 Hz

Polumschaltbare Motoren (separate Versorgung)	BN 63...BN 132
	230Δ / 400Y V ±10% – 50 Hz
	460Y - 60 Hz

Falls nicht anderweitig angegeben, beträgt die Standardversorgung der Bremse 230 V Δ / 400 V Y - 50 Hz.

Auf Anfrage können Sonderspannungen von 24...690 V, 50-60 Hz geliefert werden.

M10.3 Technische Daten der Bremsen vom Typ FA

(F49)

Bremsen	Bremsmoment M_b [Nm]	Ansprechzeit t_1 [ms]	Bremsvorgang t_2 [ms]	W_{max} [J]			W [MJ]	P [VA]
				10 s/h	100 s/h	1000 s/h		
FA 02	3.5	4	20	4500	1400	180	15	60
FA 03	7.5	4	40	7000	1900	230	25	80
FA 04	15	6	60	10000	3100	350	30	110
FA 14								
FA 05	40	8	90	18000	4500	500	50	250
FA 15								
FA 06S	60	16	120	20000	4800	550	70	470
FA 06	75	16	140	29000	7400	800	80	550
FA 07	150	16	180	40000	9300	1000	130	600
FA 08	250	20	200	60000	14000	1500	230	1200

M_b = statisches max. Bremsmoment ($\pm 15\%$)

t_1 = Bremsenansprechzeit

t_2 = Bremsverzögerung

W_{max} = max. Energie pro Bremsvorgang (Wärmeleistung der Bremse)

W = Bremsenergie zwischen zwei Einstellungen des Luftspalts

P_b = bei 20° von der Bremse aufgenommene Leistung (50 Hz)

s/h = Schaltspiele pro Stunde

HINWEIS:

Die in der Tabelle angegebenen Werte t_1 und t_2 beziehen sich auf eine Bremse mit eingestelltem Nenndrehmoment, einen mittleren Luftspalt und mit Standardspannung.



Der Verschleiß der Reibdichtungen ist von den Betriebsbedingungen abhängig (Temperatur, Feuchtigkeit, Schlupfgeschwindigkeit, spezifischer Druck); die Verschleißangaben sind demnach als Richtwerte zu betrachten.

M10.4 Anschlüsse - Bremsentyp FA

Bei den Motoren mit direkter Bremsenspannungsversorgung müssen die Anschlüsse im Klemmkasten entsprechend den Angaben im Schema (F50) vorgenommen werden:

(F50)

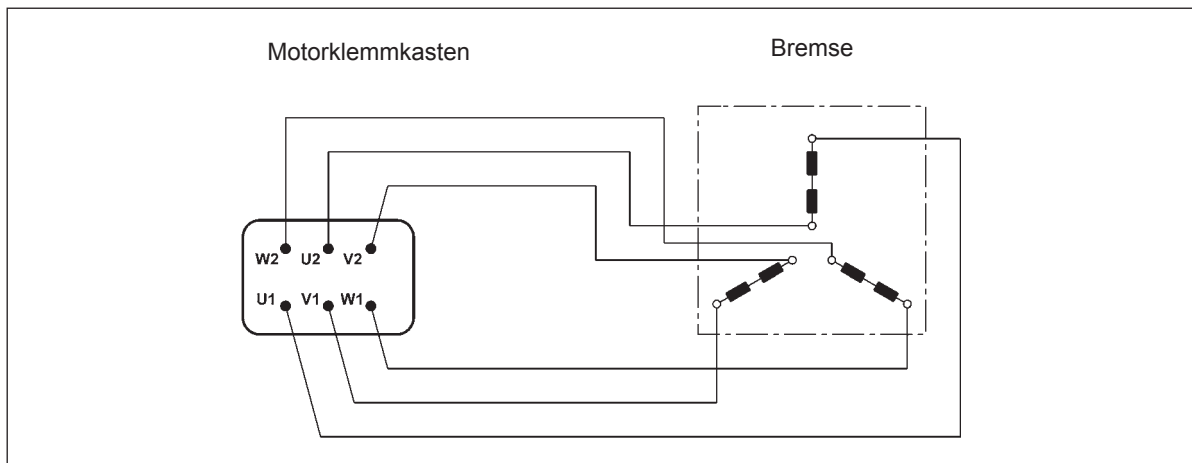

Bei den polumschaltbaren Motoren und, auf Anfrage, auch bei den einpoligen Motoren mit separater Versorgungsspannung ist für den Anschluss der Bremse ein Hilfsklemmbrett mit 6 Anschlüssen vorgesehen. Dann haben die Motoren einen größeren Klemmkasten. Siehe Schema (F51):

(F51)

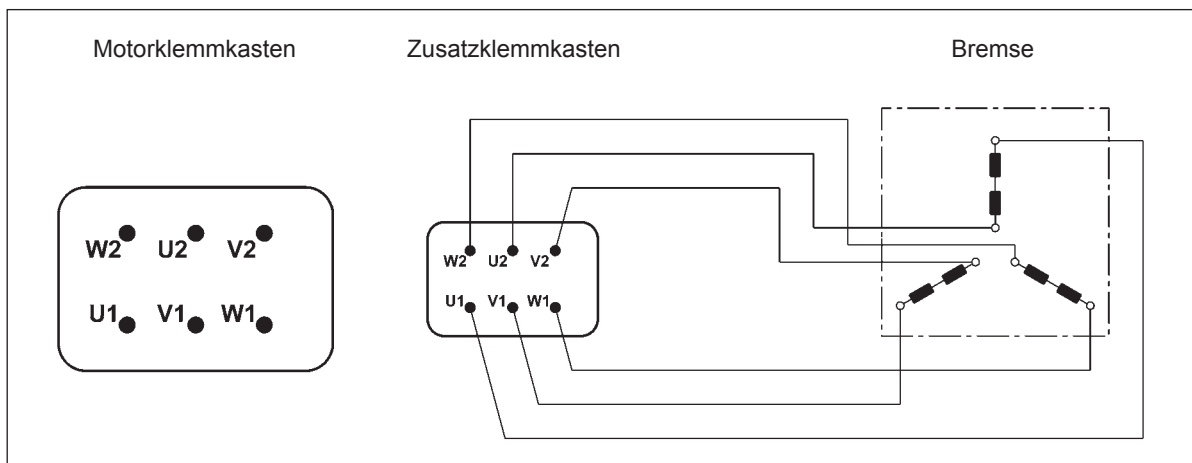



M11 BREMSLÜFTHEBEL

Für Instandhaltungsarbeiten können die Federdruckbremsen vom Typ FD, AFD und FA optional mit Bremslüfthebeln geliefert werden, um ein manuelles Lüften zu ermöglichen.

R

(F52)

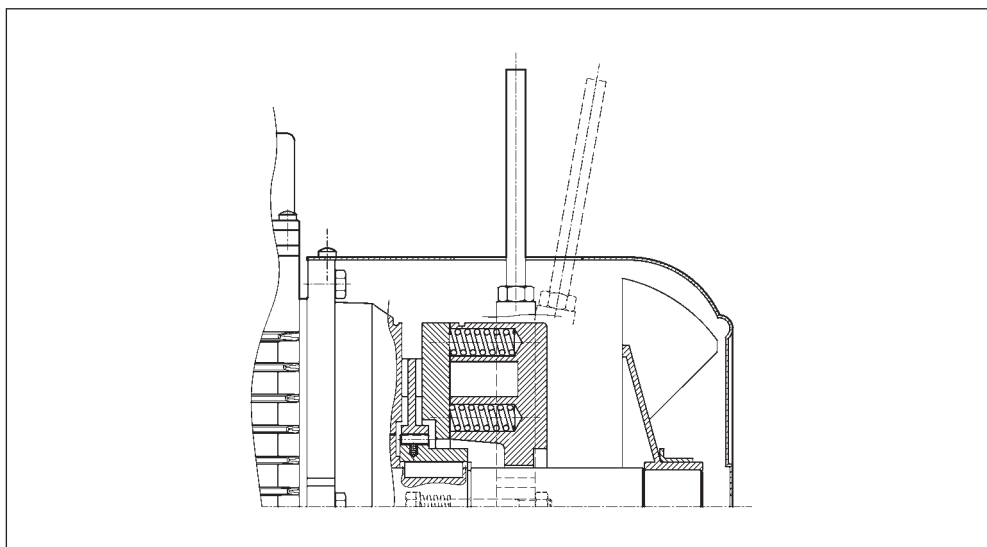

Bremslüfthebel mit automatischer Rückstellung durch Federkraft.

RM

(F53)

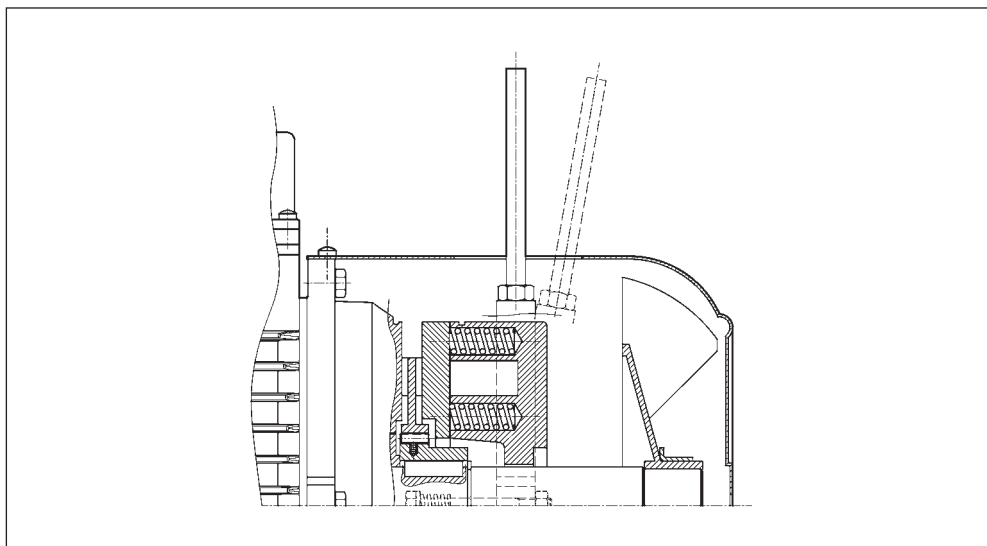

Der Bremslüfthebel kann bei Bedarf in der Lüftposition arretiert werden, wenn man diesen bis zur Bremsenarretierung einschraubt.

Je nach Motortyp sind unterschiedliche Bremslüftsysteeme verfügbar, die Sie der folgenden Tabelle entnehmen können:



(F54)

	R	RM
BN_FD	BN 63...BN 200	BN 63 ... BN 132 FD07
BN_AFD	BN 63...BN 160MR	
BN_FA	BN 63...BN 180M	

M11.1 Ausrichtung des Bremsl ufthebels

Der Bremsl ufthebel wird bei den Optionen **R** und **RM** standardm a ig um 90° im Uhrzeigersinn zur Position des Klemmkastens montiert (Position **[AB]** in der nachfolgenden Zeichnung).

Andere Positionen: **AA** (0° zum Klemmkasten), **AC** (180° zum Klemmkasten) oder **AD** (270° zum Klemmkasten), im Uhrzeigersinn vom L ufer aus gesehen, k onnen auf Wunsch geliefert werden:

(F55)

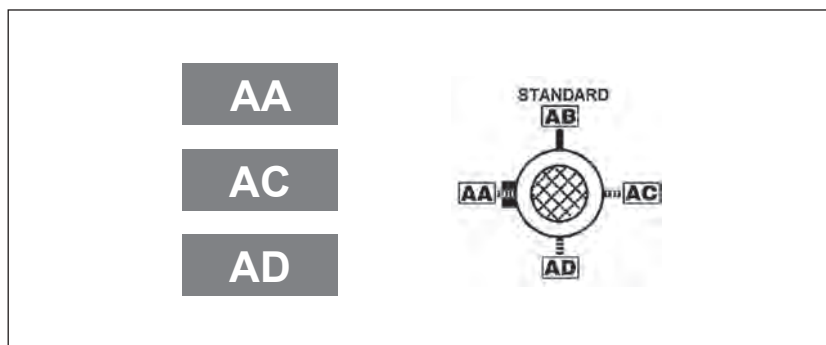





M12 OPTIONEN

M12.1 Sanftanlauf / stop

F1

Für Anwendungen, bei denen einer sanfte Anlauf-und Stop erforderlich ist, steht als - Option F1 - ein Schwungrad zur Verfügung, dessen zusätzliches Trägheitsmoment während der Anlaufphase kinetische Energie aufnimmt, die in der Abbremsphase wieder abgegeben wird. Dadurch erfolgen die Übergangsphasen progressiver und sanfter. Das Schwungrad ist für die Bremsmotoren vom Typ BN_FD und BN_AFD in den nachstehend aufgeführten spezifischen Details verfügbar:

(F56)

Eigenschaften der Schwungräder für Motoren typ: BN_FD, BN_AFD, M_FD, M_AFD			
		Gewicht Schwungrad [Kg]	Trägheitsmoment Schwungrad [Kgm ²]
BN 63	M05	0.69	0.00063
BN 71	M1	1.13	0.00135
BN 80	M2	1.67	0.00270
BN 90 S - BN 90 L	–	2.51	0.00530
BN 100	M3	3.48	0.00840
BN 112	–	4.82	0.01483
BN 132 S - BN 132 M	M4	6.19	0.02580

M12.2 Kapazitiver filter

CF

Nur bei den Bremsmotoren mit Gleichstrombremse vom Typ BN_FD und BN_AFD ist die Option eines kapazitiven Filters vorgesehen. Wird dieser Filter vor dem Gleichrichter (Option CF) installiert, fallen die Motoren in die von der Norm EN61000-6-3:2007" Elektromagnetische Kompatibilität – Allgemeine Norm zur Emission – Teil 6-3: Wohngebiete, Handels- und Leichtindustriezonen" vorgesehene Emissionsgrenzen.

12.3 Thermische wicklungsschutzeinrichtungen

Standardmäßig werden Motoren durch externe Motorschutzschalter gegen Überlastung geschützt. Optional können die Motoren mit integrierten Temperaturfühlern ausgestattet werden, die die Wicklung vor Überhitzung aufgrund einer unzureichenden Luftzufuhr oder bei Aussetzbetrieb schützen. Diese Option wird auch für Motoren mit Fremdlüftung dringend empfohlen (IC416).

M12.4 PTC-Thermistoren

E3

Hierbei handelt es sich um Halbleiter, die eine schnelle Änderung des Widerstands kurz vor der Nennansprechtemperatur (150 °C) aufweisen. Der Verlauf der Kennlinie $R = f(T)$ ist durch die DIN-Normen 44081 und IEC 34-11 festgelegt. Im allgemeinen werden Thermistoren mit positivem Temperaturkoeffizienten verwendet, die unter der Bezeichnung PTC (Kaltleiter) bekannt sind. Die Thermistoren sind nicht in der Lage, die Relais direkt anzusteuern, und müssen deshalb an ein entsprechendes Auslösegerät angeschlossen werden. Die Anschlüsse der drei in den Wicklungen in Reihe geschalteten PTC-Widerstände sind an einer Zusatzklemmleiste verfügbar.



K1

Es handelt sich hierbei um eine Untergruppe der PTC-Thermistoren; ihre Baueigenschaften ermöglichen den Einsatz als Temperaturfühler, da sie einen positiven Temperaturkoeffizienten in Abhängigkeit vom Widerstand aufweisen.

Die Betriebstemperatur beträgt: 0°C ... +260°C.

Die Thermistoren sind nicht in der Lage, die Relais direkt anzusteuern, und müssen deshalb an ein entsprechendes Auslösegerät angeschlossen werden.

Die Anschlussklemmen (gepolt) von 1 KTY 84-130 sind in einer Hilfsklemmenleiste verfügbar.

M12.5 Bimetall-Temperaturfühler

D3

Diese Schutzeinrichtungen enthalten in einer Kaspel eine Bimetallscheibe, die bei Erreichen der Nennansprechtemperatur (150 °C) einen Schaltkontakt öffnet. Bei abnehmender Temperatur schließt dieser Kontakt wieder. Normalerweise werden die Öffnerkontakte von drei Bimetallfühlern in Reihe geschaltet und auf einer Zusatzklemmleiste zur Verfügung gestellt.

M12.6 Motor mit Verbinder

CON

Es stehen drei Verbindertypen (CON 1, CON 2, CON 3) zur Verfügung, die in zwei Einbaupositionen installiert werden können: rechte Seite des Klemmenkastens (C1D, C2D, C3D); linke Seite des Klemmenkastens (C1S, C2S, C3S).

Die CON-Option steht für die BN und M-Motoren mit einzelner Polarität (2, 4, 6, 8 Pole) und BX/BE und MX/ME je nach Größe wie in der folgenden Liste beschrieben zur Verfügung. Alle polumschaltbaren Motoren sind ausgenommen.

Die Verbinder sind für die BX-BE/MX-ME und BN/M in der Version ohne Bremse und für die BN und M-Bremsmotoren mit Gleichstrombremse FD oder AFD in den Größen gemäß nachstehender Tabelle erhältlich.

Am Motor ist der (Stecker-) Verbinder (mit Stiften) befestigt, während der (Buchsen-) Verbinder nicht zum Lieferumfang zählt.

Mit der CON-Option ist stets der Y-Anschluss der Phasen vorgesehen.

Für die Fremdlüftermotoren (Option U1) ist der Anschluss zur Versorgung des Lüfters im separaten, an der Lüfterabdeckung befestigten Klemmenkasten vorgesehen.

Bei den Motoren mit Encoder (Optionen EN1...EN6) erfolgt der Anschluss des Encoders mit einem losen Kabel, das nicht am Verbinder angeschlossen ist.

Die CON-Option ist für die Motoren mit Wechselstrombremse FA nicht anwendbar.



Technische Daten

(F57)

Option	CON 1
Motor-Baugrosse	BE 80 ... BE 112 / ME2, ME3 / BN 63 ... BN 112 / M05 ... M3
Ansicht des Verbinders	
Verbindertyp	Harting Han 10ES
Verbindergehäuse	Han EMC 10B mit 2 Hebeln
Stiftanzahl - Nennstrom	10 x 16A
Versorgungsspannung	500 Vac
Anschlussart der Kontakte	Schraubklemmen

(F58)

Option	CON 2
Motor-Baugrosse	BX 132 / BE 80 ... BE 132M / MX4 / ME4 / BN 63 ... BN 132M / M05 ... M4L
Ansicht des Verbinders	
Verbindertyp	Harting Han Modular
Verbindergehäuse	Han EMC 10B mit 2 Hebeln
Modultyp	Modul C + Leeres Modul + Modul E
Stiftanzahl - Nennstrom	3 x 36A / 6 x 16A
Versorgungsspannung	500 Vac
Anschlussart der Kontakte	Crimpkontakte

(F59)

Option	CON 3
Motor-Baugrosse	BX 132 / BE 80 ... BE 132M / MX4 / ME4 / BN 63 ... BN 132M / M05 ... M4L
Ansicht des Verbinders	
Verbindertyp	Harting Han Modular
Verbindergehäuse	Han EMC 10B mit 2 Hebeln
Modultyp	Modul C + Modul E + Modul E
Stiftanzahl - Nennstrom	3 x 36A / 6 + 6 x 16A
Versorgungsspannung	500 Vac
Anschlussart der Kontakte	Crimpkontakte



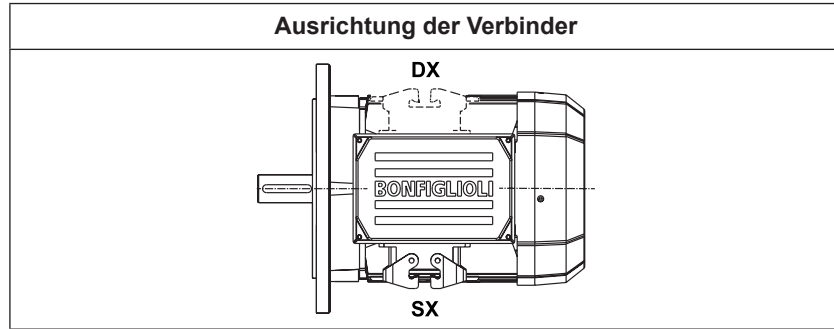

(F60)



(F61)

Abmessungen der Motoren ohne Bremse

		AD (mm)	AF (mm)	AH (mm)	LL (mm)	V ^(*) (mm)
BN 63	M05	136	110	45	165	4.5
BN 71	M1	149	110	45	165	15.5
BE 80 - BN 80	ME2 - M2	160	110	45	165	16.5
BE 90 - BN 90	—	162	110	45	165	31.5
BE 100 - BN 100	ME3 - M3	171	110	45	165	37.5
BE 112 - BN 112	—	186	110	45	165	39
BX 132 - BE 132 - BN 132	MX4 - ME4 - M4	210	140	45	188	45.5
BN 160MR	—	210	140	45	188	161

(*) Dimension gilt nur für Motoren BX, BE und BN.

(F62)

Abmessungen der Motoren mit FD-Bremse

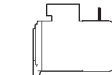
		AD (mm)	AF (mm)	AH (mm)	LL (mm)	V ^(*) (mm)
BN63	M05	136	110	45	165	4.5
BN71	M1	149	110	45	165	1.5
BN80	M2	160	110	45	165	18.5
BN90	—	162	110	45	165	39.5
BN100	M3	171	110	45	165	63.5
BN112	—	186	110	45	165	75
BN132	M4	210	140	45	188	122
BN160MR	—	210	140	45	188	161

(*) Dimension gilt nur für Motoren BN.



M12.7 Kontrolle der Funktionstüchtigkeit der Bremse

MSW

Der Mikroschalter kann entsprechend eingestellt werden, um das Anziehen / Lösen des beweglichen Ankers oder das Erreichen des zulässigen Höchstwerts für den Luftspalt zu melden.

Die MSW-Option ist für die Bremsen FD03...FD09 und AFD03...AFD07 verfügbar.

Der Mikroschalter ist mit drei Anschlussklemmen NC, NO, COM versehen. In der nachfolgenden Zeichnung sind die wesentlichen Komponenten der mit Mikroschalter ausgestatteten Bremse dargestellt.

(F63)

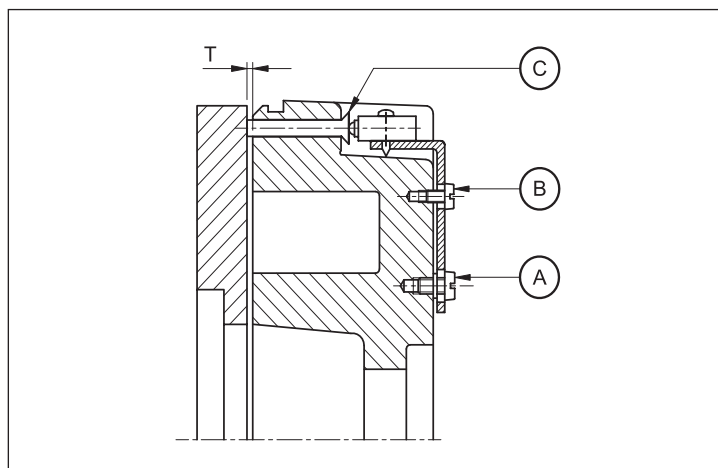

- A: Befestigungsschrauben
- B: Einstellschraube
- C: Antrieb

M12.8 Zusätzlicher Kabeleingang für Bremsmotoren

IC

Am Klemmenkasten der Bremsmotoren BN63...BN160MR / M05...M4 sind zwei zusätzliche Kabeleingänge M16 x 1,5 verfügbar (einer pro Seite).

Am Klemmenkasten der Bremsmotoren BN160...BN200 / M5 ist ein zusätzlicher Kabeleingang M16 x 1,5 neben dem Eingang des Bremskabels verfügbar.

M12.9 Wicklungsheizung

H1

NH1

Die Motoren, die in besonders feuchten Umgebungen und/oder unter starken Temperaturschwankungen eingesetzt werden, können mit einem Heizelement als Kondenswasserschutz ausgestattet werden.

Die einphasige Versorgung erfolgt über eine Zusatzklemmleiste, die sich im Klemmkasten befindet. Werte fuer die Leistungsaufnahme sind in folgender Tabelle aufgeführt.



(F64)

	H1	NH1
	1~ 230V ± 10% P [W]	1~ 115V ± 10% P [W]
BE 80 BN 56 ... BN 80	10	10
BX 132 BE 90 ... BE 132MB BN 90 ... BN 160MR	25	25
BX 160, BX 180 BE 160, BE 180 BN 160, BN 200	50	50

Warnung!

Während des Motorbetriebs darf die Wicklungsheizung nie in Betrieb sein.

M12.10 Tropenschutz

TP

Wird die Option **TP** bestellt, wird die Motorwicklung mit einem zusätzlichen Schutz ausgestattet, der ihren Einsatz unter hohen Temperaturen und starker Feuchtigkeit ermöglicht.

M12.11 Zweites Wellenende

PS

Diese Option schließt die Optionen RC, TC, U1, U2, EN1, EN2, EN3, EN4, EN5, EN6. Die entsprechenden Abmessungen können den Maßtabellen der Motoren entnommen werden.

(F65)

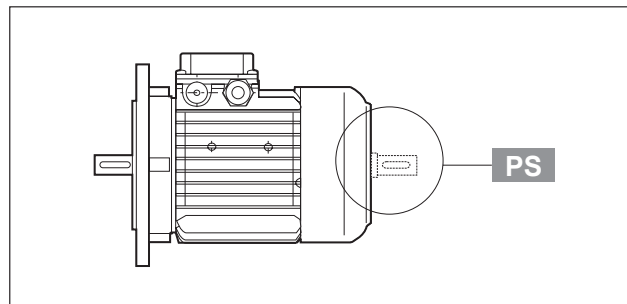

M12.12 Rücklaufsperr

AL AR

Wenn ein durch die Last verursachtes Zurückdrehen des Motors verhindert werden soll, kann eine Rücklaufsperr integriert werden (nur bei Serie MX/ME und M verfügbar). Diese Vorrichtung, die eine völlig ungehinderte Drehung des Motors in Laufrichtung gestattet, greift sofort ein, wenn die Spannung fehlt, und verhindert die Drehung der Welle in die Gegenrichtung. Die Rücklaufsperr verfügt über eine Dauerschmierung mit einem speziell für diese Anwendung geeignetem Fett. Bei der Bestellung muss die vorgesehene Drehrichtung des Motors angegeben werden. Die Rücklaufsperr darf keinesfalls verwendet werden, um im Falle eines fehlerhaften elektrischen Anschlusses die Drehung in die Gegenrichtung zu verhindern. In Tabelle (F71) sind die Nenn- und Höchstdrehmomente für die verwendeten Rücklaufsperr angegeben; Abbildung (F72) zeigt eine schematische Darstellung der Vorrichtung. Die Abmessungen sind ähnlich denen der Bremsmotoren. Die Richtungsangabe der freien Rotation ist in dem Getriebeteil des Katalogs unter dem Abschnitt „OPTIONEN MOTOREN“ beschrieben.



(F66)

	Nenn Drehmoment der Sperre	Max. Drehmo- ment der Sperre	Ausrückge- schwindigkeit
	[Nm]	[Nm]	[min ⁻¹]
M1	6	10	750
ME2 M2	16	27	650
ME3 M3	54	92	520
MX4 - ME4 M4	110	205	430

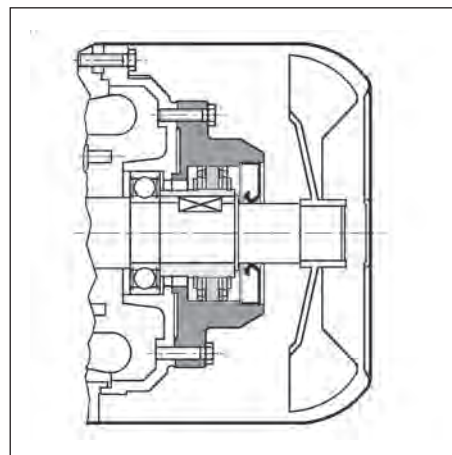

M12.13 Rotorauswuchtung

RV

Sollte eine besondere Laufruhe gefordert werden, steht als Option RV eine Ausführung mit reduziertem Schwingverhalten nach Grad B, zur Verfügung.

Die folgende Tabelle gibt die Werte der effektive Schwingungen für das normale Auswuchten (A) und im Grad B an.

Diese Werte beziehen sich auf einem frei hängenden und sich im Leerbetrieb befindlichen Motor; Toleranz ±10%.

(F67)

Vibrationlevel	Winkelgeschwindigkeit n [min ⁻¹]	Grenzen der Schwingungsstärke (mm/s)
		BX 132 ≤ H ≤ BX 180L BE 80 ≤ H ≤ BE 180L BN 56 ≤ H ≤ BN 200
A	600 < n < 3600	1.6
B	600 < n < 3600	0.70

M12.14 Belüftung

Die Motoren werden mittels Eigenbelüftung gekühlt (IC 411 gemäss CEI EN 60034-6) und sind mit einem Radiallüfterrad aus Kunststoff ausgestattet, welches in beiden Drehrichtungen wirksam ist. Bei der Montage des Motors muss darauf geachtet werden, dass zwischen Lüfterhaube und dem nächsten Bauteil ein Mindestabstand eingehalten wird, um die Luftzirkulation nicht zu beeinträchtigen. Dieser Abstand ist ebenso für die regelmäßige Wartung des Motors und, falls vorhanden, der Bremse erforderlich. Ab der Baugröße BN 71 und M1 können die Motoren auf Anfrage mit einem unabhängig gespeisten Fremdlüfter geliefert werden. Die Kühlung erfolgt hier durch einen Axialventilator, der an Stelle der Standardlüfterhaube (Kühlmethode IC 416) montiert wird.

Diese Ausführung sollte eingesetzt werden, falls der Motor über einen Frequenzumrichter auch bei kleinen Drehzahlen mit Nennmoment betrieben wird oder bei hoher Schaltheufigkeit.



Von dieser Option ausgeschlossen sind die Motoren mit zweitem Wellenende (Option PS).



Für diese Option sind als Alternative zwei Ausführungen verfügbar: **U1** und **U2** mit gleichen Längenmaßen. Für beide Ausführungen wird die Verlängerung der Lüfterhaube (**DL**) in der nachstehenden Tabelle angegeben.

Die Gesamtmaße der Motoren können den Tabellen mit den Motormaßen entnommen werden.

(F68)

Tabelle - Motorverlängerung			
		ΔL_1	ΔL_2
BN 71	M1	184	–
BE 80 - BN 80	ME2 - M2	93	32
BE 90 - BN 90	–	127	55
BE 100 - BN 100	ME3 - M3	131	48
BE 112 - BN 112	–	119	28
BX - 132 - BE 132 - BN 132	MX4 - ME4 - M4	130	31
BX 160 - BE 160, BX 180 - BE, 180	MX5 - ME5	161	51

ΔL_1 = Maßänderung gegenüber Maß LB des entsprechenden Standardmotors.

ΔL_2 = Maßänderung gegenüber Maß LB des entsprechenden Bremsmotors. Nur für Motoren BN.



U1

Versorgungsanschlüsse des Ventilators befinden sich im Zusatzklemmkasten.

Bei den Bremsmotoren in der Baugröße BN 71 ... BN 160MR, M1 ... M4L, mit Option **U1**, kann der Bremslüfthebel nicht in der Position AA stehen. Die Option ist nicht verfügbar für die Motoren entsprechend den Normen CSA und UL (Option CUS).

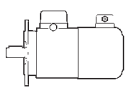
(69)



		V a.c. $\pm 10\%$	Hz	P [W]	I [A]
BN 71	M1	1 ~ 230	50 / 60	22	0.12
BE 80 BN 80	ME2 M2			22	0.12
BE 90 BN 90	–			40	0.30
BE 100 BN 100	ME3 M3			50	0.25
BE 112 BN 112	–			50	0.26 / 0.15
BX 132 - BE 132 BN 132 ... BN 160MR	MX4 - ME4 M4L	3 ~ 230 Δ / 400Y	50	110	0.38 / 0.22
BX 160 - BE 160 BN 160M ... BN 180M	MX5 - ME5 M5			180	1.25 / 0.72
BX 180 - BE 180 BN 180L ... BN 200L	–			250	1.51 / 0.87





U2

Versorgungsanschlüsse des Ventilators befinden sich im Hauptklemmkasten des Motors.

Die Option **U2** ist nicht verfügbar für die Motoren BX, BE, MX, ME und nicht für Motoren mit CUS-Option (entsprechend den Normen CSA und UL).

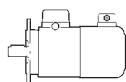
(70)





		V a.c. ±10%	Hz	P [W]	I [A]
BN 71	M1	1 ~ 230	50 / 60	22	0.12
BN 80	M2			22	0.12
BN 90	—			40	0.30
BN 100	M3	3 ~ 230Δ / 400Y		40	0.26 / 0.09
BN 112	—			50	0.26 / 0.15
BN 132 ... BN 160MR	M4L			110	0.38 / 0.22

M12.15 Regenschutzdach

RC

Das Regenschutzdach RC wird empfohlen, wenn der Motor senkrecht mit einer nach unten gerichteten Welle montiert wird. Es dient dem Schutz des Motors vor dem Eindringen von festen Fremdkörpern und Tropfwasser. Die Abmessungen werden in der folgende Tabelle angegeben. Die Schutzdachoption schließt die Möglichkeit der Optionen PS, EN1, EN2, EN3, EN4, EN5, EN6.

(71)

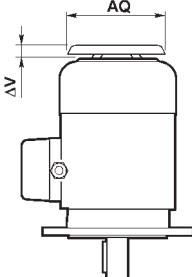
		AQ	ΔV	
BN 63	M05	118	24	
BN 71	M1	134	27	
BE 80 BN 80	ME2 M2	152	25	
BE 90 BN 90	—	168	30	
BE 100 BN 100	ME3 M3	190	28	
BE 112 BN 112	—	211	32	
BX 132 - BE 132 BN 132...BN 160MR	MX4 - ME4 M4	254	32	
BX 160 - BE 160 BN 160M...BN 180M	MX5 - ME5 M5	302	36	
BX 180 - BE 180 BN 180L...BN 200L	—	340	36	



M12.16 Textilschutzdach

TC

Bei der Option TC handelt es sich um ein Schutzdach mit einem Textilnetz, dessen Einsatz empfohlen wird, wenn der Motor in Bereichen der Textilindustrie installiert wird, in denen Stofffusseln das Lüfterradgitter verstopfen und so einen ausreichenden Kühlluftfluss verhindern könnten. Diese Option schließt die Möglichkeit der Optionen EN1, EN2, EN3, EN4, EN5, EN6, PS, U1, U2. Die Gesamtmaße entsprechen denen des Schutzdachs vom Typ RC.

M12.17 Drehgeberanschluss

Die Motoren können mit sechs unterschiedlichen Encodertypen ausgestattet werden. Nachstehend finden Sie die entsprechenden Beschreibungen. Die Montage eines Encoders schließt die Version mit zweitem Wellenende (PS) und Schutzdach (RC, TC) aus.

EN1

Inkremental-Encoder, $V_{IN} = 5\text{ V}$, Ausgang „line-driver“ RS 422.

EN2

Inkremental-Encoder, $V_{IN} = 10\text{-}30\text{ V}$, Ausgang „line-driver“ RS 422

EN3

Inkremental-Encoder, $V_{IN} = 12\text{-}30\text{ V}$, Ausgang „push-pull“ 12-30 V

EN4

Encoder sin/cos, $V_{IN} = 4,5\text{-}5,5\text{ V}$, Sinus-Ausgang $0,5\text{ V}_{PP}$.

EN5

Absolut-Encoder mit Einzelwindung, Schnittstelle HIPERFACE®, $V_{IN} = 7\text{-}12\text{ V}$.

EN6

Absolut-Encoder mit Mehrfachwindung, Schnittstelle HIPERFACE®, $V_{IN} = 7\text{-}12\text{ V}$.
(F72)

	EN1	EN2	EN3	EN4	EN5	EN6
Schnittstelle	TTL/RS 422	TTL/RS 422	HTL/push-pull	Sinus 0.5 VPP	HIPERFACE®	HIPERFACE®
Versorgungsspannung [V]	4...6	10...30	12...30	4.4...5.5	7...12	7...12
Ausgangsspannung [V]	5	5	12...30	—	—	—
Betriebsstrom ohne Belastung [mA]	120	100	100	40	80	80
Impulse pro Drehung	1024					
Positionen pro Umdrehung	—	—	—	—	15 bit	15 bit
Revolutionen	—	—	—	—	—	12 bit
Signale	6 (A, B, Z + invertierte Signale)			6 (cos-, cos+, sin-, sin+, Z, \bar{Z})	—	—
Max. Ausgangsfrequenz [kHz]	600			200		
Max. Drehzahl [min ⁻¹]	6000 (9000 min ⁻¹ für 10 s)					
Temperaturbereich [°C]	-30 ... +100					
Schutzgrad	IP 65					



(F73)

EN1, EN2, EN3, EN4, EN5, EN6	
BX 132 ... BX 180L	MX2 ... MX5L
BE 80 ... BE 180L	ME2S ... ME5L
BN 63 ... BN 200L	M05 ... M5
BN 63_FD ... BN 200L_FD	M05_FD ... M5_FD
BN 63_AFD ... BN 160MR_AFD	M05_AFD ... M5_AFD
BN 63_FA ... BN 200L_FA	M05_FA ... M5_FA

(F74)

EN_ + U1		
		L3
BX 160 - BE 160 - BN 160M...BN 180M	MX5 - ME5 - M5	72
BX 180 - BE 180 - BN 180L...BN 200L	–	82
BN 160M_FD...BN 180M_FD	M5_FD	35
BN 180L_FD...BN 200L_FD	–	41

Wenn der Encoder (Option EN_) für Motoren der Baugrößen BE80B ... BX/BE132MB , ME2 ... MX/ME4 - BN71...BN160MR , M1 ... M4 zusammen mit Fremdlüftung (Optionen U1, U2) ausgelegt ist, stimmen die Maßänderungen des Motors mit jenen der entsprechenden Ausführungen U1 und U2 überein.



M12.18 Oberflächenschutz

C
_

Wenn keine besondere Korrosionsschutzklasse gefordert ist, ist die lackierte Oberfläche des Motors mindestens mit einem Schutz gegen Korrosion der Klasse C2 nach UNI EN ISO 12944-2 geschützt. Für eine bessere Witterungsbeständigkeit können die Motor durch eine Lackierung mit einem Oberflächenschutz der Klassen C3 und C4 geliefert werden.

(F75)

OBERFLÄCHENSCHUTZ	Typische Umgebungen	Maximale Oberflächen-temperatu	Korrosionsschutzklasse nach UNI EN ISO 12944-2
C3	Stadt- und Industrieumgebung mit bis zu 100% relativer Luftfeuchtigkeit (mittlere Luftverschmutzung)	120°C	C3
C4	Industrie- und Küstengebiete und Chemieanlagen mit bis zu 100% relativer Luftfeuchtigkeit (hohe Luftverschmutzung)	120°C	C4

Die Motoren mit einem optionalen Korrosionsschutz der Klassen C3 oder C4 sind in einer Auswahl von Farben verfügbar. Wenn keine spezielle Farbe gefordert ist, (siehe Option „Lackierung“) ist der Decklack in RAL 7042.

Unsere Motor können auch mit Oberflächenschutz der Klasse C5 nach UNI EN ISO 12944-2 versehen werden. Für weitere technische Informationen wenden Sie bitte an unseren Technischen Service.

M12.19 Lackierung

RAL

Die Motoren mit Oberflächenschutz der Klasse C3 oder C4, sind in den, in der folgenden Liste aufgelisteten Farben, verfügbar.

(F76)

LACKIERUNG	Farbe	RAL Nummer
RAL7042*	Traffic Grey A	7042
RAL5010	Gentian Blue	5010
RAL9005	Jet Black	9005
RAL9006	White Aluminium	9006
RAL9010	Pure White	9010

* Die Getriebe werden in dieser Standardfarbe geliefert, wenn keine andere Farbe angegeben ist.

Hinweis – Die Option „Lackierung“ kann nur im Zusammenhang mit dem Oberflächenschutz spezifiziert werden.



M12.20 Nachweise

ACM

Konformitätsbescheinigung von Motoren Dokument mit dessen Ausstellung die Konformität des Produkts mit dem Auftrag, und dessen Konstruktion in Konformität mit den vom Qualitätsmanagementsystem von Bonfiglioli Riduttori vorgesehenen Standardfertigungs- und -kontrollverfahren bescheinigt wird.



CC

Prüfzeugnis

Die Bestellung führt zur Durchführung von Kontrollen der Konformität mit dem Auftrag, allgemeinen Sichtkontrollen und instrumentalen Prüfung der elektrischen Eigenschaften in unbelasteten Bedingungen. Die Prüfung wird anhand einer Stichprobe des Versandloses durchgeführt.



M13 TABELLE MOTORZUORDNUNG

(F77)



2 poligen						
	IE1	IE2	IE3	IE1	IE2	IE3
Wirkungsgradklasse						
0.06						
0.09						
0.12						
0.18	BN 63A 2			M 05A 2		
0.25	BN 63B 2			M 05B 2		
0.37	BN 71A 2			M 05C 2		
0.55	BN 71B 2			M 1SD 2		
0.75	BN 71C 2 BN 80A 2	BE 80A 2		M 1LA 2	ME 2SA 2	
1.1	BN 80B 2	BE 80B 2		M 2SA 2	ME 2SB 2	
1.5	BN 90SA 2	BE 90SA 2		M 2SB 2		
1.85	BN 90SB 2					
2.2	BN 90L 2	BE 90L 2		M 3SA 2		
3	BN 100L 2	BE 100L 2		M 3LA 2	ME 3LB 2	
4	BN 112M 2	BE 112M 2		M 3LB 2		
5.5	BN 132SA 2	BE 132SA 2		M 4SA 2	ME 4SA 2	
7.5	BN 132SB 2	BE 132SB 2		M 4SB 2	ME 4LA 2	
9.2	BN 132M 2	BE 132MB 2		M 4LA 2	ME 4LB 2	
11	BN 160MR 2 BN 160M 2	BE 160MA 2		M 4LC 2	ME 5SA 2	
15	BN 160MB 2	BE 160MB 2		M 5SB 2	ME 5SB 2	
18.5	BN 160L 2	BE 160L 2		M 5SC 2	ME 5LA 2	
22	BN 180M 2			M 5LA 2		
30	BN 200LA 2					



(F78)



4 poligen							
Wirkungsgradklasse	IE1	IE2	IE3	IE1	IE2	IE3	
Pn [kW]	0.06	BN 56A 4					
	0.09	BN 56B 4			M 0B 4		
	0.12	BN 63A 4			M 05A 4		
	0.18	BN 63B 4			M 05B 4		
	0.25	BN 63C 4			M 05C 4		
		BN 71A 4					
	0.37	BN 71B 4			M 1SD 4		
	0.55	BN 71C 4			M 1LA 4		
		BN 80A 4					
	0.75	BN 80B 4	BE 80B 4		M 2SA 4	ME 2SB 4	
	1.1	BN 80C 4	BE 90S 4		M 2SB 4	ME 3SA 4	
		BN 90S 4					
	1.5	BN 90LA 4	BE 90LA 4		M 3SA 4	ME 3SB 4	
	1.85	BN 90LB 4					
	2.2	BN 100LA 4	BE 100LA 4		M 3LA 4	ME 3LA 4	
	3	BN 100LB 4	BE 100LB 4		M 3LB 4	ME 3LB 4	
	4	BN 112M 4	BE 112M 4		M 3LC 4	ME 4SA 4	
	5.5	BN 132S 4	BE 132S 4	BX 132SB 4	M 4SA 4	ME 4SB 4	MX 4SB 4
	7.5	BN 132MA 4	BE 132MA 4	BX 132MA 4	M 4LA 4	ME 4LA 4	MX 4LA 4
	9.2	BN 132MB 4	BE 132MB 4	BX 160MA 4	M 4LB 4	ME 4LB 4	MX 5SA 4
11	BN 160MR 4	BE 160M 4	BX 160MB 4	M 4LC 4	ME 5SA 4	MX 5SB 4	
	BN 160M 4						
15	BN 160L 4	BE 160L 4	BX 160L 4	M 5SB 4	ME 5LA 4	MX 5LA 4	
18.5	BN 180M 4	BE 180M 4	BX 180M 4	M 5LA 4			
22	BN 180L 4	BE 180L 4	BX 180L 4				
30	BN 200L 4						

(F79)



6 poligen							
Wirkungsgradklasse	IE1	IE2	IE3	IE1	IE2	IE3	
Pn [kW]	0.06						
	0.09	BN 63A 6			M 05A 6		
	0.12	BN 63B 6			M 05B 6		
	0.18	BN 71A 6			M 1SC 6		
	0.25	BN 71B 6			M 1SD 6		
		BN 71C 6					
	0.37	BN 80A 6			M 1LA 6		
	0.55	BN 80B 6			M 2SA 6		
	0.75	BN 80C 6	BE 90S 6		M 2SB 6		
		BN 90S 6					
	1.1	BN 90L 6			M 3SA 6		
	1.5	BN 100LA 6	BE 100LA 6		M 3LA 6	ME 3LB 6	
	1.85	BN 100LB 6			M 3LB 6		
	2.2	BN 112M 6	BE 112M 6		M 3LC 6		
	3	BN 132S 6	BE 132S 6		M 4SA 6	ME 4SB 6	
	4	BN 132MA 6	BE 132MA 6		M 4LA 6	ME 4LA 6	
	5.5	BN 132MB 6	BE 160MA 6		M 4LB 6	ME 5SA 6	
	7.5	BN 160M 6	BE 160MB 6		M 5SA 6	ME 5SB 6	
	9.2						
	11	BN 160L 6			M 5SB 6		
15	BN 180L 6						
18.5	BN 200LA 6						
22							
30							

M14 MOTORENAUSWAHLTABELLEN BX-MX

4 P	1500 min⁻¹ - S1	50 Hz - IE3
------------	-----------------------------------	--------------------

P _n kW		n min ⁻¹	M _n Nm	I _n 400V A	η%			cos φ	I _s I _n	M _s M _n	M _a M _n	J _m x 10 ⁻⁴ kgm ²	IM B5 	
					100%	75%	50%							
5.5	BX 132SB	4	1470	36	11.5	89.6	89.2	87.3	0.77	6.6	2.9	2.9	310	57
7.5	BX 132MA	4	1460	49	15.0	90.4	90.9	90.2	0.80	7.9	3.4	3.0	360	67
9.2	BX 160MA	4	1465	60	18.3	91.0	91.4	90.6	0.80	6.1	2.5	2.2	650	95
11	BX 160MB	4	1465	72	20.9	91.4	92.3	92.0	0.83	6.4	2.5	2.3	780	110
15	BX 160L	4	1465	98	28.3	92.1	92.7	92.4	0.83	6.7	2.5	2.1	890	121
18.5	BX 180M	4	1473	120	33.2	92.6	93.3	92.4	0.86	10.4	2.5	2.9	1560	155
22	BX 180L	4	1474	143	39.0	93.0	93.3	92.6	0.87	10.0	2.1	2.6	1660	163

4 P	1500 min⁻¹ - S1	50 Hz - IE3
------------	-----------------------------------	--------------------

P _n kW		n min ⁻¹	M _n Nm	I _n 400V A	η%			cos φ	I _s I _n	M _s M _n	M _a M _n	J _m x 10 ⁻⁴ kgm ²	IM B9 	
					100%	75%	50%							
5.5	MX 4SB	4	1470	36	11.5	89.6	89.2	87.3	0.77	6.6	2.9	2.9	310	55
7.5	MX 4LA	4	1460	49	15.0	90.4	90.9	90.2	0.80	7.9	3.4	3.0	360	65
9.2	MX 5SA	4	1465	60	18.3	91.0	91.4	90.6	0.80	6.1	2.5	2.2	650	79
11	MX 5SB	4	1465	72	20.9	91.4	92.3	92.0	0.83	6.4	2.5	2.3	780	96
15	MX 5LA	4	1465	98	28.3	92.1	92.7	92.4	0.83	6.7	2.5	2.1	890	107



M15 MOTORENABMESSUNGEN BX-MX

BX - IM B5

BX-MX

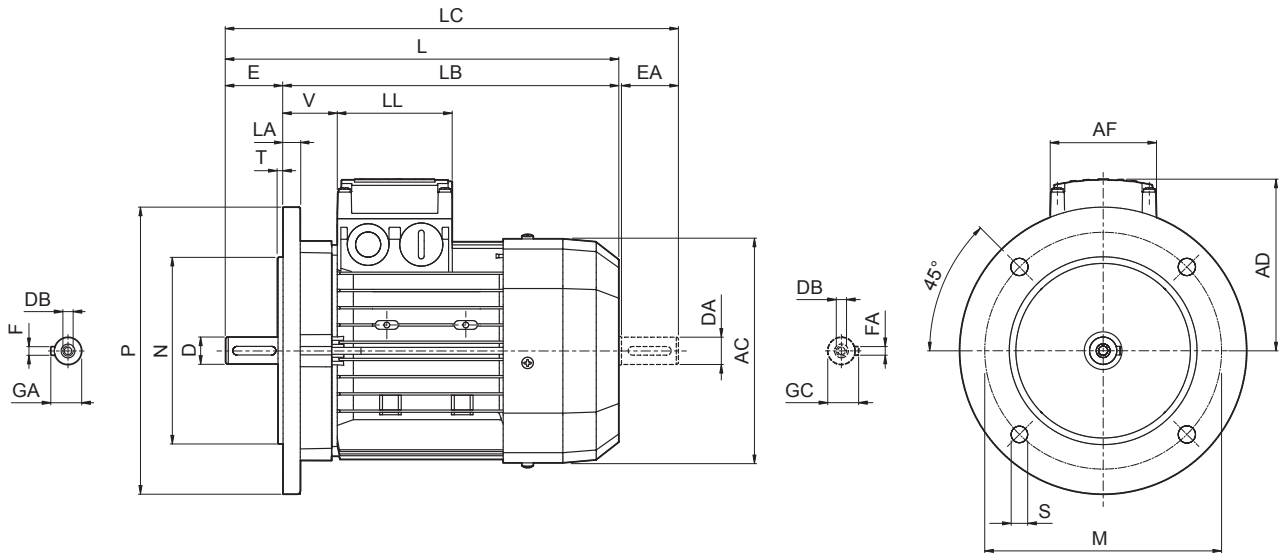

	Welle					Flansch						Motor							
	D DA	E EA	DB	GA GC	F FA	M	N	P	S	T	LA	AC	L	LB	LC	AD	AF	LL	V
BX 132 SB	38	80	M12	41	10	265	230	300	14	4	16	258	493	413	556	193	118	118	58
BX 132 MA	28 ⁽¹⁾	60 ⁽¹⁾	M10 ⁽¹⁾	31 ⁽¹⁾	8 ⁽¹⁾								528	448	591				
BX 160 MA	42 38 ⁽¹⁾	110 80 ⁽¹⁾	M16 M12 ⁽¹⁾	45 41 ⁽¹⁾	12 10 ⁽¹⁾	300	250	350	18.5	5	15	310	596	486	680	245	187	187	51
BX 160 MB													640	530	724				
BX 160 L													640	530	724				
BX 180 M	48	110	M16	51.5	14	300	250	350	18.5	5	18	348	708	598	823	261			52
BX 180 L	42 ⁽¹⁾	110 ⁽¹⁾	M16 ⁽¹⁾	45 ⁽¹⁾	12 ⁽¹⁾								708	598	823				

HINWEIS:

1) Diese Maße betreffen das zweite Wellenende.

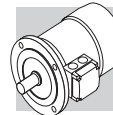

BX - IM B14

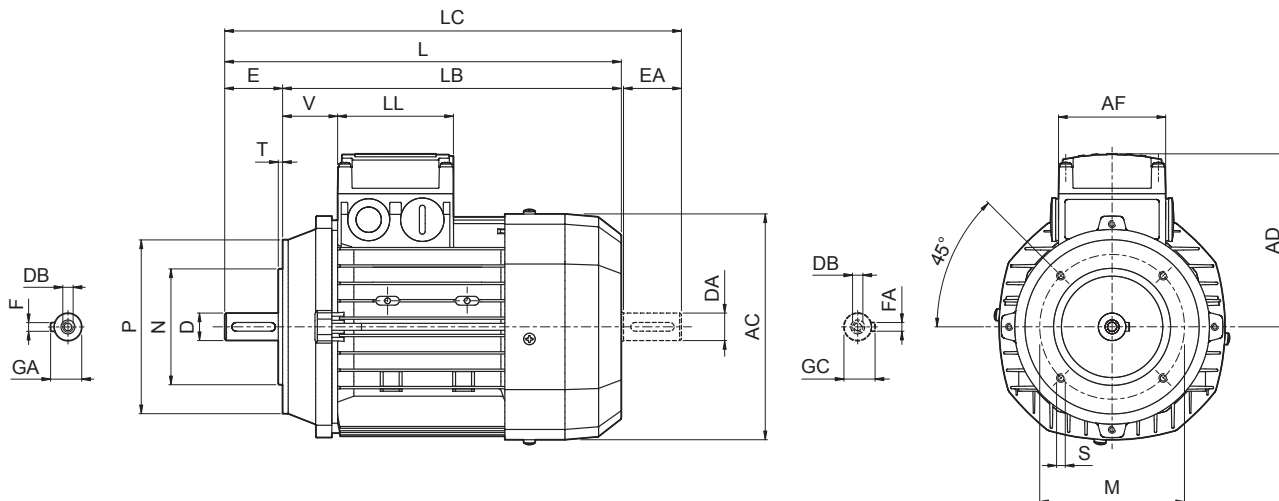

	Welle					Flansch					Motor							
	D DA	E EA	DB	GA GC	F FA	M	N	P	S	T	AC	L	LB	LC	AD	AF	LL	V
BX 132 SB	38	80	M12	41	10	165	130	200	M10	4	258	493	413	556	193	118	118	58
BX 132 MA	28 ⁽¹⁾	60 ⁽¹⁾	M10 ⁽¹⁾	31 ⁽¹⁾	8 ⁽¹⁾						528	448	591					

HINWEIS:

1) Diese Maße betreffen das zweite Wellenende.



MX

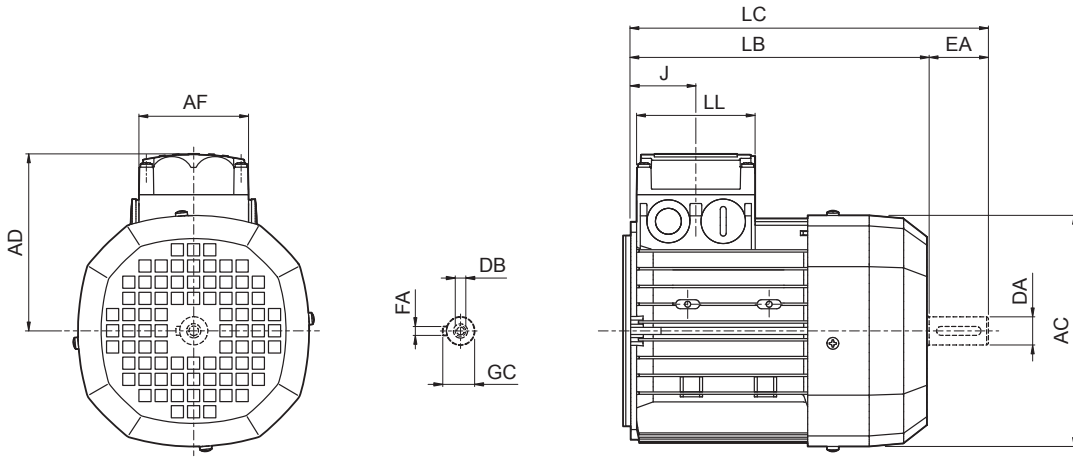

BX-MX





	Zweite Wellenende					Motor						
	DA	EA	DB	FA	GC	AC	LB	LC	AF	LL	J	AD
MX 4SB	28	60	M10	8	31	258	361	424	118	118	64.5	193
MX 4LA							396	459				
MX 5SA	38	80	M12	10	41	310	418	502	187	187	77	245
MX 5SB							462	546				
MX 5LA												

M16 MOTORENAUSWAHLTABELLEN BE-ME

2 P	3000 min⁻¹ - S1	50 Hz - IE2
------------	-----------------------------------	--------------------

P _n kW		n min ⁻¹	M _n Nm	I _n 400V A	η%			cos φ	$\frac{I_s}{I_n}$	$\frac{M_s}{M_n}$	$\frac{M_a}{M_n}$	J _m x 10 ⁻⁴ kgm ²	IM B5 	
					100%	75%	50%							
0.75	BE 80A	2	2860	2.5	1.65	80.0	79.6	76.4	0.83	6.8	3.8	3.5	9.0	9.5
1.1	BE 80B	2	2845	3.7	2.35	81.5	82.2	79.9	0.83	6.9	3.8	3.1	11.4	11.3
1.5	BE 90SA	2	2865	5.0	3.2	81.3	80.7	78.1	0.82	6.8	3.6	2.8	12.5	12.3
2.2	BE 90L	2	2870	7.3	4.7	83.2	83.1	80.8	0.82	6.9	3.1	2.9	16.7	14
3	BE 100L	2	2880	9.9	6.2	84.6	84.6	83.7	0.83	7.3	3.5	3.1	39	23
4	BE 112M	2	2920	13.1	8.2	85.8	85.5	84.3	0.82	7.9	3.5	3.1	57	28
5.5	BE 132SA	2	2925	18.0	10.6	87.0	85.0	81.7	0.86	8.5	3.6	3.3	145	42
7.5	BE 132SB	2	2935	24	14.3	88.1	87.4	84.7	0.86	8.8	3.9	3.6	178	53
9.2	BE 132MB	2	2920	30	16.4	88.8	86.5	84.2	0.91	8.4	3.7	3.3	210	65
11	BE 160MA	2	2940	36	20.0	89.4	89.5	88.0	0.89	8.1	3.0	2.9	340	84
15	BE 160MB	2	2950	49	27.2	90.5	90.5	89.5	0.88	8.5	3.0	2.8	420	97
18.5	BE 160L	2	2945	60	32	90.9	90.5	89.8	0.91	7.7	2.9	2.7	490	109



4 P	1500 min⁻¹ - S1	50 Hz - IE2
------------	-----------------------------------	--------------------

P _n kW		n min ⁻¹	M _n Nm	I _n 400V A	η%			cos φ	$\frac{I_s}{I_n}$	$\frac{M_s}{M_n}$	$\frac{M_a}{M_n}$	J _m x 10 ⁻⁴ kgm ²	IM B5 	
					100%	75%	50%							
0.75	BE 80B	4	1430	5.0	1.65	81.0	80.5	78.0	0.81	6.1	3.2	3.0	28	12.2
1.1	BE 90S	4	1430	7.4	2.53	82.5	82.0	79.5	0.76	6.3	2.9	2.8	28	13.6
1.5	BE 90LA	4	1430	10.0	3.5	83.5	83.0	80.0	0.74	5.9	3.1	3.0	34	15.1
2.2	BE 100LA	4	1430	14.7	4.9	85.4	85.0	84.0	0.76	5.8	3.0	2.8	54	22
3	BE 100LB	4	1420	20	6.6	85.5	86.0	85.5	0.77	5.9	2.8	2.6	61	24
4	BE 112M	4	1440	27	8.3	87.0	87.0	86.0	0.80	6.5	2.8	2.8	105	32
5.5	BE 132S	4	1460	36	11.1	88.5	88.5	87.5	0.81	7.3	2.9	2.9	270	53
7.5	BE 132MA	4	1460	49	14.8	89.0	89.0	88.5	0.82	6.9	2.9	2.8	319	59
9.2	BE 132MB	4	1460	60	18.1	89.5	89.5	88.5	0.82	6.9	2.9	3.0	360	70
11	BE 160M	4	1465	72	21.5	91.0	91.3	90.5	0.81	6.5	2.8	2.6	650	99
15	BE 160L	4	1465	98	28.7	90.8	91.0	90.5	0.83	6.5	2.6	2.3	790	115
18.5	BE 180M	4	1465	121	35	91.6	92.0	91.3	0.83	6.5	2.6	2.5	1250	135
22	BE 180L	4	1465	143	41	91.6	91.8	91.4	0.84	6.8	2.7	2.6	1650	157



BE-ME



6 P	1000 min⁻¹ - S1	50 Hz - IE2
------------	-----------------------------------	--------------------

P _n kW		n min ⁻¹	M _n Nm	I _n 400V A	η%			cos φ	$\frac{I_s}{I_n}$	$\frac{M_s}{M_n}$	$\frac{M_a}{M_n}$	J _m x 10 ⁻⁴ kgm ²	IM B5  Kg
					100%	75%	50%						
0.75	BE 90S 6	935	7.7	2.06	75.9	75.9	73.0	0.69	5.1	3.1	2.9	33	15
1.1	BE 100M 6 (*)	945	11.1	2.75	78.1	76.2	73.0	0.74	4.9	2.2	1.9	82	22
1.5	BE 100LA 6	945	15.2	3.9	79.8	77.5	74.0	0.72	5.6	2.5	2.3	95	24
2.2	BE 112M 6	950	22	5.2	81.8	81.8	79.3	0.74	5.2	2.6	2.3	168	32
3	BE 132S 6	955	30	6.6	83.3	83.3	82.4	0.79	6.1	2.1	1.9	295	44
4	BE 132MA 6	965	40	8.7	84.6	85.0	83.1	0.79	6.9	2.2	2.0	383	56
5.5	BE 160MA 6 (*)	965	54	11.6	87.0	87.0	86.4	0.79	6.6	2.5	2.3	740	83
7.5	BE 160MB 6 (*)	965	74	15.0	88.0	88.0	87.2	0.82	6.6	2.3	2.1	970	103



(*) Das Verhältnis Leistung / Größe ist nicht genormt



2 P	3000 min⁻¹ - S1	50 Hz - IE2
------------	-----------------------------------	--------------------



P _n kW		n min ⁻¹	M _n Nm	I _n 400V A	η%			cos φ	$\frac{I_s}{I_n}$	$\frac{M_s}{M_n}$	$\frac{M_a}{M_n}$	J _m x 10 ⁻⁴ kgm ²	IM B9 	
					100%	75%	50%							
0.75	ME 2SA	2	2860	2.5	1.63	80.0	79.6	76.4	0.83	6.8	3.8	3.5	9.0	8.8
1.1	ME 2SB	2	2845	3.7	2.35	81.5	82.2	79.9	0.83	6.9	3.8	3.1	11.4	10.6
1.5	ME 3SA	2	2845	5.0	3.2	81.3	79.0	76.0	0.84	6.1	2.9	2.7	24	15.5
2.2	ME 3LA	2	2895	7.3	4.8	83.2	83.2	81.5	0.80	6.3	2.7	2.5	31	18.7
3	ME 3LB	2	2880	9.9	6.2	84.6	84.6	83.7	0.83	7.3	3.5	3.1	39	22
4	ME 4SA	2	2900	13.2	7.8	85.8	84.5	82.2	0.87	7.0	2.9	2.8	101	33
5.5	ME 4SB	2	2925	18.0	10.6	87.0	85.0	81.7	0.86	8.5	3.6	3.3	145	40
7.5	ME 4LA	2	2935	24	14.3	88.1	87.4	84.7	0.86	8.8	3.9	3.6	178	51
9.2	ME 4LB	2	2920	30	16.4	88.8	86.5	84.2	0.91	8.4	3.7	3.3	210	60
11	ME 5SA	2	2940	36	20.0	89.4	89.5	88.0	0.89	8.1	3.0	2.9	340	70
15	ME 5SB	2	2950	49	27.2	90.5	90.5	89.5	0.88	8.5	3	2.8	420	83
18.5	ME 5LA	2	2945	60	32	90.9	90.5	89.8	0.91	7.7	2.9	2.7	490	95

4 P	1500 min⁻¹ - S1	50 Hz - IE2
------------	-----------------------------------	--------------------

P _n kW		n min ⁻¹	M _n Nm	I _n 400V A	η%			cos φ	$\frac{I_s}{I_n}$	$\frac{M_s}{M_n}$	$\frac{M_a}{M_n}$	J _m x 10 ⁻⁴ kgm ²	IM B9 	
					100%	75%	50%							
0.75	ME 2SB	4	1430	5.0	1.65	81.0	80.5	78.0	0.81	6.1	3.2	3	28	10.9
1.1	ME 3SA	4	1430	7.4	2.60	82.5	82.0	79.0	0.74	5.5	2.5	2.8	34	15.5
1.5	ME 3SB	4	1420	10.1	3.48	84.0	84.0	83.0	0.74	6.2	2.9	2.9	40	17
2.2	ME 3LA	4	1430	14.7	4.89	85.4	85.0	84.0	0.76	5.8	3	2.8	54	21
3	ME 3LB	4	1420	20	6.58	85.5	86.0	85.5	0.77	5.9	2.8	2.6	61	23
4	ME 4SA	4	1440	27	8.25	87.5	86.8	84.0	0.80	7.1	3.0	3.1	213	42
5.5	ME 4SB	4	1460	36	11.07	88.5	88.5	87.5	0.81	7.3	2.9	2.9	270	51
7.5	ME 4LA	4	1460	49	14.83	89.0	89.0	88.5	0.82	6.9	2.9	2.8	319	57
9.2	ME 4LB	4	1460	60	18.09	89.5	89.5	88.5	0.82	6.9	2.9	3	360	65
11	ME 5SA	4	1465	72	21.54	91.0	91.3	90.5	0.81	6.5	2.8	2.6	650	85
15	ME 5LA	4	1465	98	28.73	90.8	91.0	90.5	0.83	6.5	2.6	2.3	790	101



6 P	1000 min⁻¹ - S1	50 Hz - IE2
------------	-----------------------------------	--------------------

P _n kW		n min ⁻¹	M _n Nm	I _n 400V A	η%			cos φ	$\frac{I_s}{I_n}$	$\frac{M_s}{M_n}$	$\frac{M_a}{M_n}$	J _m x 10 ⁻⁴ kgm ²	IM B9 	
					100%	75%	50%							
0.75	ME 3SA	6	940	7.6	1.98	75.9	75.0	70.7	0.72	4.7	2.2	2.0	33	17
1.1	ME 3LA	6 (*)	945	11.1	2.75	78.1	76.2	73.0	0.74	4.9	2.2	1.9	82	21
1.5	ME 3LB	6	945	15.2	3.8	79.8	77.5	74.0	0.72	5.6	2.5	2.3	95	23
2.2	ME 4SA	6	955	22	4.9	81.8	81.8	80.0	0.80	5.7	1.9	1.7	216	34
3	ME 4SB	6	955	30	6.6	83.3	83.3	82.4	0.79	6.1	2.1	1.9	295	43
4	ME 4LA	6	965	40	8.6	84.6	85	83.1	0.79	6.9	2.2	2	383	54
5.5	ME 5SA	6 (*)	965	54	11.6	87.0	87.0	86.4	0.79	6.6	2.5	2.3	740	69
7.5	ME 5SB	6 (*)	965	74	15.0	88.0	88.0	87.2	0.82	6.6	2.3	2.1	970	89

(*) Das Verhältnis Leistung / Größe ist nicht genomt



M17 MOTORENABMESSUNGEN BE-ME

BE - IM B5

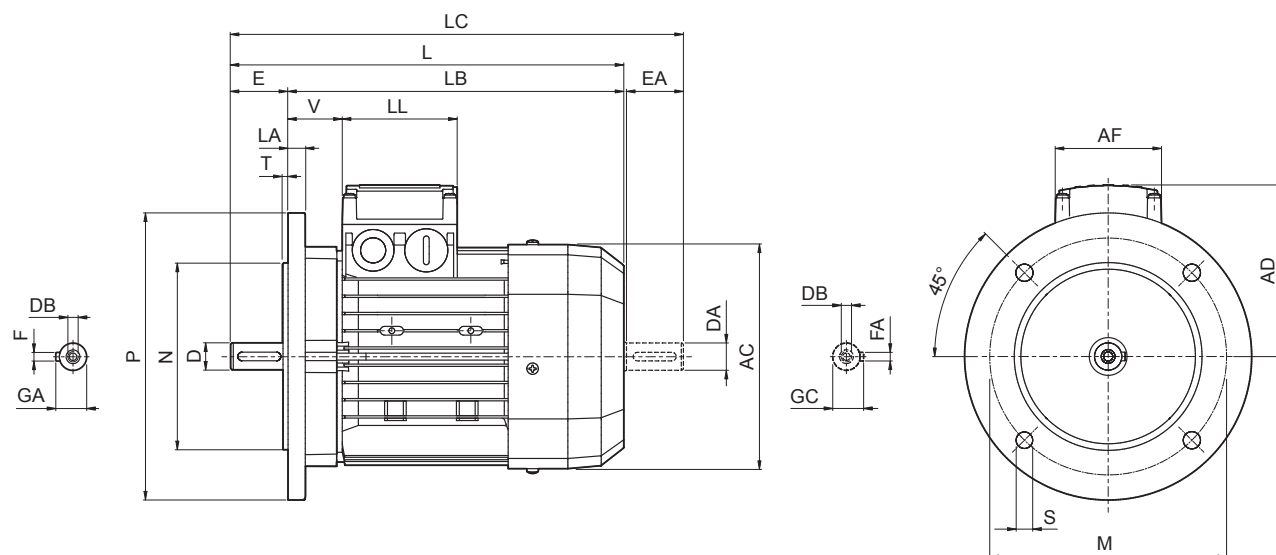

	Welle					Flansch					Motor									
	D DA	E EA	DB	GA GC	F FA	M	N	P	S	T	LA	AC	L	LB	LC	AD	AF	LL	V	
BE 80	19	40	M6	21.5	6							156	274	234	315	119	74	80	38	
BE 90 S	24	50	M8	27	8	165	130	200	11.5	3.5	11.5	176	326	276	378	133	98	98	44	
BE 90 L																				
BE 100	28	60	M10	31		215	180	250			14	195	367	307	429	142			50	
BE 112																				15
BE 132 S	38	80	M12	41	10	265	230	300	14	4	16	258	493	413	576	193	118	118	58	
BE 132 MA																				
BE 132 MB													528	448	611					
BE 160 M	42 38 ⁽¹⁾	110 80 ⁽¹⁾	M16 M12 ⁽¹⁾	45 41 ⁽¹⁾	12 10 ⁽¹⁾						15	310	596	486	680	245			51	
BE 160 L													640	530	724					
BE 180 M	48 42 ⁽¹⁾	110 110 ⁽¹⁾	M16 M16 ⁽¹⁾	51.5 45 ⁽¹⁾	14 12 ⁽¹⁾	300	250	350	18.5	5		18	348	708	598	823	261	187	187	52
BE 180 L																				

HINWEIS:

1) Diese Maße betreffen das zweite Wellenende.

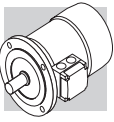

BE - IM B14

BE-ME

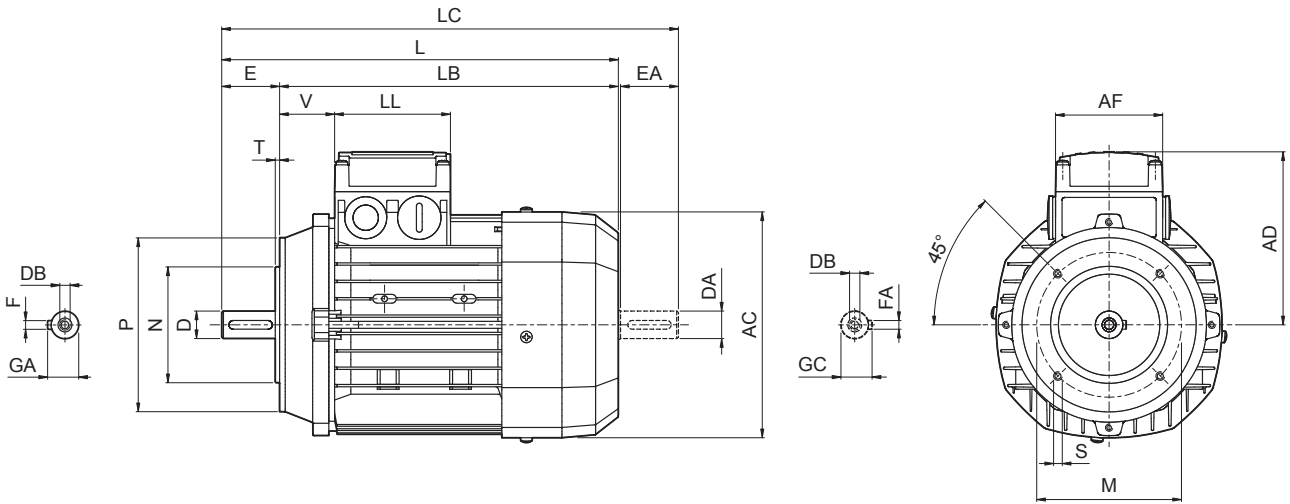

	Welle					Flansch					Motor							
	D DA	E EA	DB	GA GC	F FA	M	N	P	S	T	AC	L	LB	LC	AD	AF	LL	V
BE 80	19	40	M6	21.5	6	100	80	120	M6	3	156	274	234	315	119	74	80	38
BE 90 S	24	50	M8	27	8	115	95	140	M8		176	326	276	378	133	98	98	44
BE 90 L						130	110	160		195	367	307	429	142	50			
BE 100	28	60	M10	31	8	130	110	160	M8	3.5	219	385	325	448	157	98	98	52
BE 112											258	493	413	576	193			118
BE 132 S	38	80	M12	41	10	165	130	200	M10	4	258	528	448	611	193	118	118	58
BE 132 MA																		
BE 132 MB																		



ME

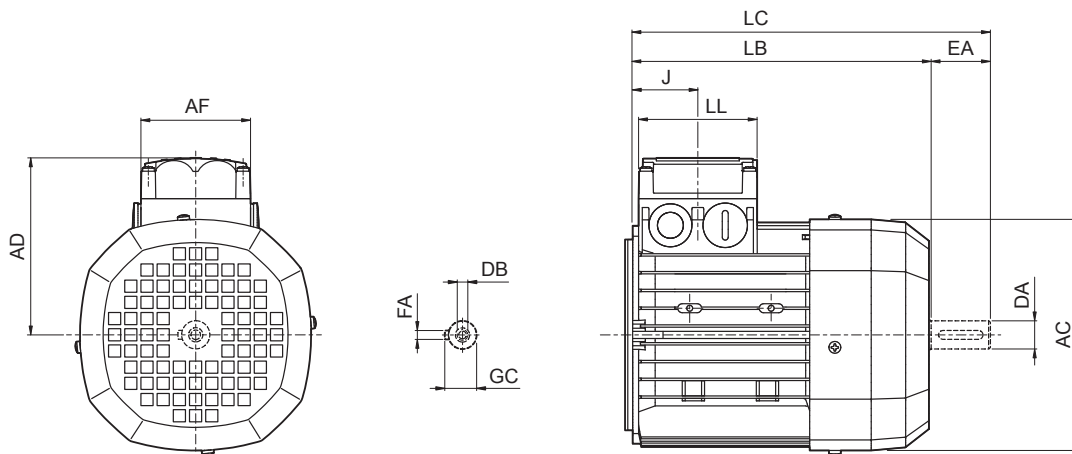

BE-ME

	Zweite Wellenende					Motor						
	DA	EA	DB	FA	GC	AC	LB	LC	AF	LL	J	AD
ME 2S	19	40	M6	6	21.5	156	202	245	74	80	44	119
ME 3S	28	60	M10	8	31	195	230	293	98	98	53.5	142
ME 3L							262	325				
ME 4S	38	80	M12	10	41	258	361	444	118	118	64.5	193
ME 4L							396	479				
ME 4LB												
ME 5S	310	418	502	187	187	77	245					
ME 5L								462	546			



BN-M

M18 MOTORENAUSWAHLTABELLEN BN-M

2P		3000 min ⁻¹ - S1											50 Hz																
		G.S.-Bremse											W.S.-Bremse																
		G.S.-Bremse mit festem Luftspalt											G.S.-Bremse																
		FD											AFD																
P _n		n	M _n	IE1	η (100%)	η (75%)	η (50%)	cosφ	In	Is	Ms	Ma	J _m	IM B5	Mb	Z ₀	J _m	IM B5	Mod	Mb	Z ₀	J _m	IM B5	Mod	Mb	Z ₀	J _m	IM B5	
kW		min ⁻¹	Nm		%	%	%		A	in	in	Min	kgm ²	kg	Nm	1/h	kgm ²	kg		Nm	1/h	kgm ²	kg		Nm	1/h	kgm ²	kg	
0.18	BN 63A	2	2730	0.63	○	59.9	56.9	51.9	0.77	0.56	3.0	2.1	2.0	2.0	1.75	3900	4800	2.6	5.2	1.75	4800	2.6	5.0	FA 02	1.75	4800	2.6	5.0	
0.25	BN 63B	2	2740	0.87	○	66.0	64.8	64.8	0.76	0.72	3.3	2.3	2.3	3.0	1.75	3900	4800	3.0	5.6	1.75	4800	3.0	5.4	FA 02	1.75	4800	3.0	5.4	
0.37	BN 63C	2	2800	1.26	○	69.1	66.8	66.8	0.78	0.99	3.9	2.6	2.6	3.3	3.5	3600	4500	3.9	6.8	3.5	4500	3.9	6.6	FA 02	3.5	4500	3.9	6.6	
0.37	BN 71A	2	2820	1.25	○	73.8	73.0	70.6	0.76	0.95	4.8	2.8	2.6	3.5	3.5	3000	4100	4.6	8.1	3.5	4100	4.6	7.8	FA 03	3.5	4200	4.6	7.8	
0.55	BN 71B	2	2820	1.86	○	76.0	75.8	74.8	0.76	1.37	5.0	2.9	2.8	4.1	5	2900	4200	5.3	8.9	5	4200	5.3	8.6	FA 03	5	4200	5.3	8.6	
0.75	BN 71C	2	2810	2.6	○	76.6	76.2	76.2	0.76	1.86	5.1	3.1	2.8	5.0	5	1900	3300	6.1	10.0	5	3300	6.1	9.7	FA 03	5	3600	6.1	9.7	
0.75	BN 80A	2	2810	2.6	●	76.2	75.5	68.3	0.81	1.75	4.8	2.6	2.2	7.8	5	1700	3200	9.4	12.5	5	3200	9.4	12.4	FA 04	5	3200	9.4	12.4	
1.1	BN 80B	2	2800	3.8	●	76.4	76.2	75.0	0.81	2.57	4.8	2.8	2.4	9.0	10	1500	3000	10.6	13.4	10	3000	10.6	13.3	FA 04	10	3000	10.6	13.3	
1.5	BN 80C	2	2800	5.1	●	79.1	79.5	77.2	0.81	3.4	4.9	2.7	2.4	11.4	15	1300	2600	13.0	15.2	15	2600	13.0	15.1	FA 04	15	2600	13.0	15.1	
1.5	BN 90SA	2	2870	5.0	●	82.0	81.5	78.1	0.80	3.4	5.9	2.7	2.6	12.5	15	900	2200	14.1	16.5	15	2200	14.1	16.4	FA 14	15	2200	14.1	16.4	
1.85	BN 90SB	2	2880	6.1	●	82.5	82.0	75.4	0.80	4.0	6.2	2.9	2.6	16.7	15	900	2200	18.3	18.2	15	2200	18.3	18.1	FA 14	15	2200	18.3	18.1	
2.2	BN 90L	2	2880	7.3	●	82.7	82.1	80.8	0.80	4.8	6.3	2.9	2.7	16.7	14	900	2200	21	20	26	2200	21	20.7	FA 05	26	2200	21	20.7	
3	BN 100L	2	2860	10.0	●	81.5	81.3	77.4	0.79	6.7	5.6	2.6	2.2	31	26	700	1600	35	26	26	1600	35	27	FA 15	26	1600	35	27	
4	BN 100LB	2	2870	13.3	●	83.1	83.0	77.8	0.80	8.7	5.8	2.7	2.5	39	23	450	900	43	29	40	900	43	30	FA 15	40	1000	43	30	
4	BN 112M	2	2900	13.2	●	85.5	84.5	83.0	0.82	8.2	6.9	3.0	2.9	57	28	—	950	66	39	40	950	66	40	FA 06S	40	950	66	40	
5.5	BN 132SA	2	2890	18.2	●	84.7	84.5	81.2	0.84	11.2	5.9	2.6	2.2	101	35	—	600	112	48	62	600	112	49	FA 06	50	600	112	49	
7.5	BN 132SB	2	2900	25	●	86.5	86.3	84.4	0.85	14.7	6.4	2.6	2.2	145	42	—	550	154	55	62	550	154	56	FA 06	50	550	154	56	
9.2	BN 132M	2	2930	30	●	87.0	86.5	83.6	0.86	17.7	6.7	2.8	2.3	178	53	—	430	189	66	75	430	189	67	FA 06	75	430	189	67	
11	BN 160MR	2	2920	36	●	87.6	87.0	86.0	0.88	20.6	6.9	2.9	2.5	210	65	—	—	—	—	—	—	—	—	—	—	—	—	—	—
15	BN 160MB	2	2930	49	●	89.6	89.4	88.0	0.86	28.1	7.1	2.6	2.3	340	84	—	—	—	—	—	—	—	—	—	—	—	—	—	—
18.5	BN 160L	2	2930	60	●	90.4	90.1	89.0	0.86	34	7.6	2.7	2.3	420	97	—	—	—	—	—	—	—	—	—	—	—	—	—	—
22	BN 180M	2	2930	72	●	89.9	89.7	89.5	0.88	40	7.8	2.6	2.4	490	109	—	—	—	—	—	—	—	—	—	—	—	—	—	—
30	BN 200LA	2	2930	98	●	90.7	90.1	87.6	0.89	54	7.8	2.7	2.9	770	140	—	—	—	—	—	—	—	—	—	—	—	—	—	—

○ = n.a. ● = IE1

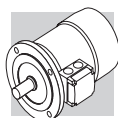



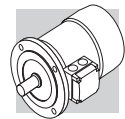

6P		1000 min ⁻¹ - S1													50 Hz															
P _n kW		n min ⁻¹	M _n Nm	IE1	η (100%) %	η (75%) %	η (50%) %	cosφ	I _n 400V A	I _s I _n	M _s M _n	I _a M _n	J _m x 10 ⁻⁴ kgm ²	IM B5 	G.S.-Bremse					G.S.-Bremse mit festem Luftspalt					W.S.-Bremse					
															FD					AFD					FA					
															Mod	Mb Nm	Z ₀ 1/h	J _m x 10 ⁻⁴ kgm ²	IM B5 	Mod	Mb Nm	Z ₀ 1/h	J _m x 10 ⁻⁴ kgm ²	IM B5 	Mod	Mb Nm	Z ₀ 1/h	J _m x 10 ⁻⁴ kgm ²	IM B5 	Mod
0.09	BN 63A	6	880	0.98	○	41.0	41.0	32.9	0.53	0.60	2.1	1.8	3.4	4.6	FD 02	3.5	9000	14000	4.0	6.3	AFD 02	3.5	14000	4.0	6.1	FA 02	3.5	14000	4.0	6.1
0.12	BN 63B	6	870	1.32	○	45.0	44.0	41.8	0.60	0.64	2.1	1.7	3.7	4.9	FD 02	3.5	9000	14000	4.3	6.6	AFD 02	3.5	14000	4.3	6.4	FA 02	3.5	14000	4.3	6.4
0.18	BN 71A	6	900	1.91	○	55.0	55.5	51.0	0.69	0.68	2.6	1.7	8.4	5.5	FD 03	5	8100	13500	9.5	8.2	AFD 03	5	13500	9.5	7.9	FA 03	5.0	13500	9.5	7.9
0.25	BN 71B	6	900	2.70	○	62.0	58.5	51.4	0.71	0.82	2.6	1.7	10.9	6.7	FD 03	5	7800	13000	12	9.4	AFD 03	5	13000	12	9.1	FA 03	5.0	13000	12	9.1
0.37	BN 71C	6	910	3.9	○	66.0	60.0	53.3	0.69	1.17	3.0	2.0	12.9	7.7	FD 53	7.5	5100	9500	14	10.4	AFD 03	7.5	9500	14	10.1	FA 03	7.5	9500	14	10.1
0.37	BN 80A	6	910	3.9	○	68.0	67.4	63.3	0.68	1.15	3.2	2.0	21	9.9	FD 04	10	5200	8500	23	13.8	AFD 04	10	8500	23	13.4	FA 04	10	8500	23	13.7
0.55	BN 80B	6	920	5.7	○	70.0	69.8	64.3	0.68	1.67	3.9	2.2	25	11.3	FD 04	15	4800	7200	27	15.2	AFD 04	15	7200	27	14.8	FA 04	15	7200	27	15.1
0.75	BN 80C	6	920	7.8	●	70.0	70.0	64.4	0.65	2.38	3.8	2.2	28	12.2	FD 04	15	3400	6400	30	16.1	AFD 04	15	6400	30	15.7	FA 04	15	6400	30	16.0
0.75	BN 90S	6	920	7.8	●	70.0	69.0	64.2	0.68	2.27	3.8	2.2	26	12.6	FD 14	15	3400	6500	28	16.8	AFD 14	15	6500	28	16.4	FA 14	15	6500	28	16.7
1.1	BN 90L	6	920	11.4	●	72.9	72.6	69.1	0.69	3.2	3.9	2.0	33	15	FD 05	26	2700	5000	37	21	AFD 05	26	5000	37	20	FA 05	26	5000	37	22
1.5	BN 100LA	6	940	15.2	●	75.2	74.2	70.3	0.72	4.0	4.1	2.0	82	22	FD 15	40	1900	4100	86	28	AFD 15	40	4100	86	27	FA 15	40	4100	86	29
1.85	BN 100LB	6	930	19.0	●	76.6	72.8	62.6	0.73	4.8	4.6	2.0	95	24	FD 15	40	1700	3600	99	30	AFD 15	40	3600	99	29	FA 15	40	3600	99	31
2.2	BN 112M	6	940	22	●	78.5	79.0	76.5	0.73	5.5	4.8	2.0	168	32	FD 06S	60	—	2100	177	42	AFD 06S	60	2100	177	41	FA 06S	60	2100	177	44
3	BN 132S	6	940	30	●	79.7	77.0	75.1	0.76	7.1	5.1	1.8	216	36	FD 56	75	—	1400	226	49	AFD 06	75	1400	226	48	FA 06	75	1400	226	50
4	BN 132MA	6	950	40	●	81.4	81.5	79.5	0.77	9.2	5.5	2.0	295	45	FD 06	100	—	1200	305	58	AFD 06	100	1200	305	57	FA 07	100	1200	318	63
5.5	BN 132MB	6	945	56	●	83.1	80.9	79.1	0.78	12.2	6.1	1.9	383	56	FD 07	150	—	1050	406	72	AFD 07	150	1050	406	70	FA 07	150	1050	406	74
7.5	BN 160M	6	955	75	●	85.0	85.0	84.8	0.81	15.7	5.9	2.0	740	83	FD 08	170	—	900	815	112	AFD 08	170	900	815	112	FA 08	170	900	815	113
11	BN 160L	6	960	109	●	86.4	86.5	85.9	0.81	22.7	6.6	2.3	970	103	FD 08	200	—	800	1045	133	AFD 08	200	800	1045	133	FA 08	200	800	1045	133
15	BN 180L	6	970	148	●	87.7	88.0	87.3	0.82	30	6.2	2.4	1550	130	FD 09	300	—	600	1750	170	AFD 09	300	600	1750	170	FA 08	170	900	815	113
18.5	BN 200LA	6	960	184	●	88.6	88.0	87.3	0.81	37	5.9	2.0	1700	145	FD 09	400	—	450	1900	185	AFD 09	400	450	1900	185	FA 08	200	800	1045	133

○ = n.a. ● = IE1



8P **750 min-1 - S1** **50 Hz**

P _n kW		n min ⁻¹	M _n Nm	η %	cosφ	In 400V A	Is In	M _s M _n	Ma M _n	J _m x 10 ⁻⁴ kgm ²	IM B5 	G.S.-Bremse						G.S.-Bremse mit festem Luftspalt						W.S.-Bremse														
												FD			AFD			FA			FD			AFD			FA			FD			AFD			FA		
												Mod	Mb Nm	Z ₀ 1/h	NB	SB	Mod	Mb Nm	Z ₀ 1/h	SB	IM B5 	J _m x 10 ⁻⁴ kgm ²	Z ₀ 1/h	SB	Mod	Mb Nm	Z ₀ 1/h	SB	IM B5 	J _m x 10 ⁻⁴ kgm ²	Z ₀ 1/h	Mb Nm	Mod	Mb Nm	Z ₀ 1/h	IM B5 	J _m x 10 ⁻⁴ kgm ²	Z ₀ 1/h
0.09	BN 71A	8	1.26	47	0.59	0.47	2.3	2.4	2.3	10.9	6.7	FD 03	3.5	9000	16000	12.0	9.4	16000	12.0	9.4	AFD 03	5	16000	16000	14.0	10.4	16000	12.0	9.1	3.5	16000	12.0	9.1	FA 03	3.5	16000	12.0	9.1
0.12	BN 71B	8	1.69	51	0.59	0.58	2.1	2.3	2.2	12.9	7.7	FD 03	5.0	9000	16000	14.0	10.4	16000	14.0	10.1	AFD 03	5	16000	16000	14.0	10.1	16000	14.0	10.1	5.0	16000	14.0	10.1	FA 03	5.0	16000	14.0	10.1
0.18	BN 80A	8	2.49	51	0.60	0.85	2.4	2.2	2.2	15	8.2	FD 04	5.0	6500	11000	16.6	12.1	11000	16.6	11.7	AFD 04	5	11000	11000	16.6	11.7	11000	16.6	11.7	5.0	11000	16.6	11.7	FA 04	5.0	11000	16.6	11.7
0.25	BN 80B	8	3.51	54	0.63	1.06	2.4	2.0	1.9	20	9.9	FD 04	10.0	6000	10000	22	13.8	10000	22	13.4	AFD 04	10	10000	10000	22	13.4	10000	22	13.4	10.0	10000	22	13.4	FA 04	10.0	10000	22	13.7
0.37	BN 90S	8	5.2	58	0.60	1.53	2.6	2.3	2.1	26	12.6	FD 14	15.0	4800	7500	28	16.8	7500	28	16.4	AFD 14	15	7500	7500	28	20.4	7500	28	16.4	15.0	7500	28	16.7	FA 14	15.0	7500	28	16.7
0.55	BN 90L	8	7.8	62	0.60	2.13	2.6	2.2	2.0	33	15	FD 05	26	4000	6400	37	21	6400	37	20.4	AFD 05	26	6400	6400	37	20.4	6400	37	20.4	26	6400	37	22	FA 05	26	6400	37	22
0.75	BN 100LA	8	10.2	68	0.63	2.53	3.4	1.9	1.7	82	22	FD 15	26	2800	4800	86	28	4800	86	27.4	AFD 15	26	4800	4800	86	27.4	4800	86	27.4	26	4800	86	29	FA 15	26	4800	86	29
1.1	BN 100LB	8	15.0	68	0.64	3.65	3.2	1.7	1.7	95	24	FD 15	40	2500	4000	99	30	4000	99	29.4	AFD 15	40	4000	4000	99	29.4	4000	99	29.4	40	4000	99	31	FA 15	40	4000	99	31
1.5	BN 112M	8	20.2	71	0.66	4.6	3.7	1.8	1.9	168	32	FD 06S	60	—	3000	177	42	3000	177	41	AFD 06S	60	3000	3000	177	41	3000	177	41	60	3000	177	44	FA 06S	60	3000	177	44
2.2	BN 132S	8	29.6	75	0.66	6.4	3.8	1.8	2.0	295	45	FD 06	75	—	2300	305	58	2300	305	56.8	AFD 06	75	2300	2300	305	56.8	2300	305	56.8	75	2300	305	56	FA 06	75	2300	305	56
3	BN 132MA	8	40.4	76	0.69	8.3	3.9	1.6	1.8	370	53	FD 06	100	—	1900	394	69	1900	394	67.8	AFD 06	100	1900	1900	394	67.8	1900	394	67.8	100	1900	394	74	FA 07	100	1900	394	74

BN-M

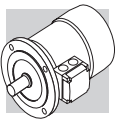

2/4P		3000/1500 min ⁻¹ - S1												50 Hz																						
G.S.-Bremse												G.S.-Bremse mit festem Luftspalt												W.S.-Bremse												
FD						AFD						FA																								
P _n	n	M _n	η	cosφ	In	Is	M _s	M _m	Ma	J _m	IM B5	Mod	Mb	Z ₀	1/h	NB	SB	J _m	IM B5	Mod	Mb	Z ₀	1/h	Nm	J _m	IM B5	Mod	Mb	Z ₀	1/h	Nm	J _m	IM B5			
kW	min ⁻¹	Nm	%		A					kgm ²	kg		Nm					kgm ²	kg		Nm			kgm ²	kgm ²	kg		Nm			kgm ²	kg				
0.20	2	2700	0.71	55	0.82	3.5	2.1	1.9	2.9	4.4	4.4	FD 02	3.5	2200	2600	4000	5100	3.5	6.1	AFD 02	3.5	2600	5100	5100	2600	5100	FA 02	3.5	2600	5100	3.5	5.9	5.9			
0.15	4	1350	1.06	49	0.67	2.6	1.8	1.7																												
0.28	2	2700	0.99	56	0.82	2.9	1.9	1.7	4.7	4.4	4.4	FD 03	3.5	2100	2400	2900	4200	5	7.1	AFD 03	5	2400	4800	4200	2400	4800	FA 03	3.5	2400	4800	5.8	6.8	6.8			
0.20	4	1370	1.39	59	0.72	3.1	1.8	1.7																												
0.37	2	2740	1.29	56	0.82	3.5	1.8	1.8	5.8	5.1	5.1	FD 03	5.0	1400	2100	2900	4200	5	7.8	AFD 03	5	2100	4200	4200	2100	4200	FA 03	5.0	2100	4200	6.9	7.5	7.5			
0.25	4	1390	1.72	60	0.73	3.3	2.0	1.9																												
0.45	2	2780	1.55	63	0.85	3.8	1.8	1.8	6.9	5.9	5.9	FD 03	5.0	1400	2100	2900	4200	5	8.6	AFD 03	5	2100	4200	4200	2100	4200	FA 03	5.0	2100	4200	8.0	8.3	8.3			
0.30	4	1400	2.0	63	0.73	3.6	2.0	1.9																												
0.55	2	2800	1.9	63	0.85	3.9	1.7	1.7	15	8.2	8.2	FD 04	5.0	1600	2300	3000	4000	5	12.1	AFD 04	5	2300	4000	4000	2300	4000	FA 04	5.0	2300	4000	17	11.7	11.7			
0.37	4	1400	2.5	67	0.79	4.1	1.8	1.9																												
0.75	2	2780	2.6	65	0.85	3.8	1.9	1.8	20	9.9	9.9	FD 04	10	1400	1600	2700	3600	10	13.8	AFD 04	10	1600	3600	3600	1600	3600	FA 04	10	1600	3600	22	13.4	13.4			
0.55	4	1400	3.8	68	0.81	3.9	1.7	1.7																												
1.1	2	2790	3.8	71	0.82	4.7	2.3	2.0	21	12.2	12.2	FD 14	10	1500	1600	2700	3600	10	16.4	AFD 14	10	1600	3600	3600	1600	3600	FA 14	10	1600	3600	23	16	16			
0.75	4	1390	5.2	66	0.79	4.6	2.4	2.2																												
1.5	2	2780	5.2	70	0.85	4.5	2.4	2.1	28	14.0	14.0	FD 05	26	1050	1200	1600	2000	26	20	AFD 05	26	1200	2000	2000	1200	2000	FA 05	26	1200	2000	32	19.4	19.4			
1.1	4	1390	7.6	73	0.81	4.7	2.5	2.2																												
2.2	2	2800	7.5	72	0.85	5.2	2.0	1.9	40	18.3	18.3	FD 15	26	600	900	1300	1700	26	25	AFD 15	26	900	1700	1700	900	1700	FA 15	26	900	1700	44	24.4	24.4			
1.5	4	1410	10.2	73	0.79	4.7	2.0	2.0																												
3.5	2	2850	11.7	80	0.84	5.4	2.2	2.1	61	25	25	FD 15	40	500	900	1000	1200	40	31	AFD 15	40	900	1200	1200	900	1200	FA 15	40	900	1200	65	30	30			
2.5	4	1420	16.8	82	0.80	5.5	2.2	2.2																												
4	2	2880	13.3	79	0.83	6.1	2.4	2.0	98	30	30	FD 06S	60	—	700	1000	1200	60	40	AFD 06S	60	700	1200	1200	700	1200	FA 06S	60	700	1200	107	39	39			
3.3	4	1420	22.2	80	0.80	7.4	2.1	2.0																												
5.5	2	2890	18.2	80	0.87	11.4	2.4	2.0	213	44	44	FD 06	75	—	350	500	600	75	57	AFD 06	75	350	600	600	350	600	FA 06	75	350	600	223	56	56			
4.4	4	1440	29	82	0.84	9.2	2.2	2.0																												
7.5	2	2900	25	82	0.87	15.2	2.4	2.0	270	53	53	FD 06	100	—	350	500	600	100	66	AFD 06	100	350	600	600	350	600	FA 07	100	350	600	280	65	65			
6	4	1430	40	84	0.85	12.1	2.3	2.1																												
9.2	2	2920	30	83	0.86	18.6	2.6	2.2	319	59	59	FD 07	150	—	300	400	500	150	75	AFD 07	150	300	500	500	300	500	FA 07	150	300	500	342	73	73			
7.3	4	1440	48	85	0.85	14.6	2.3	2.1																												

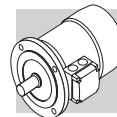





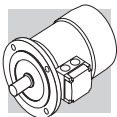

2/6P **3000/1000 min⁻¹ - S3 60/40%** **50 HZ**

P _n kW	n min ⁻¹	M _n Nm	η %	cosφ	I _n 400V A	I _s I _n	M _s M _n	M _a M _n	J _m x 10 ⁻⁴ kgm ²	IM B5 	G.S.-Bremse										G.S.-Bremse mit festem Luftspalt						W.S.-Bremse								
											FD					AFD					FA					AFD					FA				
											Mod	Mb Nm	Z ₀ 1/h	NB	SB	J _m x 10 ⁻⁴ kgm ²	IM B5 	Mod	Mb Nm	Z ₀ 1/h	SB	J _m x 10 ⁻⁴ kgm ²	IM B5 	Mod	Mb Nm	Z ₀ 1/h	Nm	J _m x 10 ⁻⁴ kgm ²	IM B5 	Mod	Mb Nm	Z ₀ 1/h	Nm	J _m x 10 ⁻⁴ kgm ²	IM B5
0.25	2850	0.84	60	0.82	0.73	4.3	1.9	1.8	6.9	5.9	FD 03	1.75	1500	1700	8.0	8.6	AFD 03	2.5	1700	13000	8.0	8.3	FA 03	2.5	1700	13000	8.0	8.3							
0.08	6 910	0.84	43	0.70	0.38	2.1	1.4	1.5					10000	13000																					
0.37	2880	1.23	62	0.80	1.08	4.4	1.9	1.8	9.1	7.3	FD 03	3.5	1000	1300	10.2	10.0	AFD 03	5	1300	11000	10.2	9.7	FA 03	3.5	1300	11000	10.2	9.7							
0.12	6 900	1.27	44	0.73	0.54	2.4	1.4	1.5					9000	11000																					
0.65	2800	1.88	63	0.86	1.47	4.5	1.9	1.7	20	9.9	FD 04	5.0	1500	1800	22	13.8	AFD 04	5	1800		22	13.4	FA 04	5.0	1800		22	13.7							
0.18	6 930	1.85	52	0.65	0.77	3.3	2.0	1.9					4100	6300																					
0.75	2800	2.6	66	0.87	1.89	4.3	1.8	1.6	25	11.3	FD 04	5.0	1700	1900	27	15.2	AFD 04	5	1900		27	14.8	FA 04	5.0	1900		27	15.1							
0.25	6 930	2.6	54	0.67	1.00	3.2	1.7	1.8					3800	6000																					
1.10	2860	3.7	67	0.84	2.82	4.7	2.1	1.9	28	14.0	FD 05	13	1400	1600	32	20	AFD 05	13	1600		32	19.4	FA 05	13	1600		32	21							
0.37	6 920	3.8	59	0.71	1.27	3.3	1.6	1.6					3400	5200																					
1.5	2880	5	73	0.84	3.53	5.1	1.9	2.0	40	18.3	FD 15	13	1000	1200	44	24	AFD 15	13	1200		44	23.4	FA 15	13	1200		44	25							
0.55	6 940	5.6	64	0.67	1.85	3.5	1.7	1.8					2900	4000																					
2.2	2900	7.2	77	0.85	4.9	5.9	2.0	2.0	61	25	FD 15	26	700	900	65	31	AFD 15	26	900		65	30	FA 15	26	900		65	32							
0.75	6 950	7.5	67	0.64	2.5	3.3	1.9	1.8					2100	3000																					
3	2900	9.9	78	0.87	6.4	6.3	2.0	2.1	98	30	FD 06S	40	—	1000	107	40	AFD 06S	40	1000		107	39	FA 06S	40	1000		107	32							
1.1	6 950	11.1	72	0.64	3.4	3.9	1.8	1.8					—	2600																					
4.5	2910	14.8	78	0.84	9.9	5.8	1.9	1.8	213	44	FD 66	37	—	500	223	57	AFD 06	37	500		223	56	FA 06	37	500		223	58							
1.5	6 960	14.9	74	0.67	4.4	4.2	1.9	2.0					—	2100																					
5.5	2920	18.0	78	0.87	11.7	6.2	2.1	1.9	270	53	FD 66	50	—	400	280	66	AFD 06	62	400		280	65	FA 06	50	400		280	67							
2.2	6 960	22	77	0.71	5.8	4.3	2.1	2.0					—	1900																					



2/8P **3000/750 min⁻¹ - S3 60/40%** **50 Hz**

P _n kW		n min ⁻¹	M _n Nm	η	cosφ	I _n 400V A	$\frac{I_s}{I_n}$	$\frac{M_s}{M_n}$	$\frac{M_a}{M_n}$	J _m x 10 ⁻⁴ kgm ²	IM B5 	G.S.-Bremse						G.S.-Bremse mit festem Luftspalt						W.S.-Bremse														
												FD			AFD			FA			FD			AFD			FA			FD			AFD			FA		
												Mod	Mb Nm	Z ₀ 1/h	NB	SB	J _m x 10 ⁻⁴ kgm ²	IM B5 	Mod	Mb Nm	Z ₀ 1/h	SB	J _m x 10 ⁻⁴ kgm ²	IM B5 	Mod	Mb Nm	Z ₀ 1/h	SB	J _m x 10 ⁻⁴ kgm ²	IM B5 	Mod	Mb Nm	Z ₀ 1/h	J _m x 10 ⁻⁴ kgm ²	IM B5 			
0.25	BN 71A	2	2790	0.86	0.87	0.68	3.9	1.8	1.9	10.9	6.7	FD 03	1.75	1300	1400	12	9.4	AFD 03	2.5	1400	1400	12	9.1	FA 03	2.5	1400	12	9.1										
0.06		8	680	0.84	0.61	0.46	2.0	1.8	1.9				10000	13000					13000																			
0.37	BN 71B	2	2800	1.26	0.86	0.99	3.9	1.8	1.9	12.9	7.7	FD 03	3.5	1200	1300	14	10.4	AFD 03	5	1300	1300	14	10.1	FA 03	3.5	1300	14	10.1										
0.09		8	670	1.28	0.75	0.51	1.8	1.4	1.5				9500	13000					13000																			
0.65	BN 80A	2	2830	1.86	0.86	1.40	4.4	2.1	2.0	20	9.9	FD 04	5.0	1500	1800	22	13.8	AFD 04	5	1800	1800	22	13.4	FA 04	5.0	1800	22	13.7										
0.13		8	690	1.80	0.64	0.72	2.3	1.6	1.7				5600	8000					8000																			
0.75	BN 80B	2	2800	2.6	0.88	1.81	4.6	2.1	2.0	25	11.3	FD 04	10	1700	1900	27	15.2	AFD 04	10	1900	1900	27	14.8	FA 04	10	1900	27	15.1										
0.18		8	690	2.5	0.66	0.92	2.3	1.6	1.7				4800	7300					7300																			
1.10	BN 90L	2	2830	3.7	0.84	3.00	4.5	2.1	1.9	28	14.0	FD 05	13	1400	1600	32	20	AFD 05	13	1600	1600	32	19.4	FA 05	13	1600	32	21										
0.28		8	690	3.9	0.63	1.34	2.4	1.8	1.9				3400	5100					5100																			
1.5	BN 100LA	2	2880	5.0	0.85	3.69	4.7	1.9	1.8	40	18.3	FD 15	13	1000	1200	44	25	AFD 15	13	1200	1200	44	14.4	FA 15	13	1200	44	25										
0.37		8	690	5.1	0.63	1.84	2.1	1.6	1.6				3300	5000					5000																			
2.4	BN 100LB	2	2900	7.9	0.82	5.6	5.4	2.1	2.0	61	25	FD 15	26	550	700	65	31	AFD 15	26	700	700	65	30	FA 15	26	700	65	32										
0.65		8	700	7.5	0.58	2.5	2.6	1.8	1.8				2000	3500					3500																			
3	BN 112M	2	2900	9.9	0.87	6.5	6.3	2.1	1.9	98	30	FD 06S	40	—	900	107	40	AFD 06S	40	900	900	107	39	FA 06S	40	900	107	42										
0.75		8	690	10.4	0.65	2.8	2.5	1.6	1.6				—	2900					2900																			
4	BN 132S	2	2870	13.3	0.84	9.4	5.6	2.3	2.4	213	44	FD 66	37	—	500	223	57	AFD 06	37	500	500	223	56	FA 06	37	500	223	58										
1		8	690	13.8	0.62	3.5	2.9	1.9	1.8				—	3500					3500																			
5.5	BN 132M	2	2870	18.3	0.84	12.6	6.1	2.4	2.5	270	53	FD 06	50	—	400	280	66	AFD 06	62	400	400	280	65	FA 06	50	400	280	67										
1.5		8	690	21	0.63	5.1	2.9	1.9	1.9				—	2400					2400																			



2/12P **3000/500 min⁻¹ - S3 60/40%** **50 HZ**



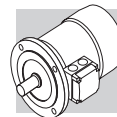



P _n kW	n min ⁻¹	M _n Nm	η	cosφ	I _n 400V A	I _s I _n	M _s M _n	M _a M _n	J _m x 10 ⁻⁴ kgm ²	IM B5 	G.S.-Bremse						G.S.-Bremse mit festem Luftspalt						W.S.-Bremse														
											FD			AFD			FA			FD			AFD			FA			FD			AFD			FA		
											Mod	Mb	Z ₀ 1/h	NB	SB	J _m x 10 ⁻⁴ kgm ²	IM B5 	Mod	Mb	Z ₀ 1/h	SB	J _m x 10 ⁻⁴ kgm ²	IM B5 	Mod	Mb	Z ₀ 1/h	SB	J _m x 10 ⁻⁴ kgm ²	IM B5 	Mod	Mb	Z ₀ 1/h	Nm	J _m x 10 ⁻⁴ kgm ²	IM B5 		
0.65	2820	1.86	64	0.89	1.39	4.2	1.6	1.7	25	11.3	1300	1000	1300	27	15.2	14.8	1300	27	14.8	1300	27	14.8	1300	27	14.8	1300	27	15.1									
0.09	12 430	2.0	30	0.63	0.69	1.8	1.9	1.8	8000	12000	8000	12000	12000	5	5	12000	5	12000	5	12000	5	12000	5	12000	5	12000	5	12000									
0.75	2790	2.6	56	0.89	2.17	4.2	1.8	1.7	26	12.6	1150	1000	1150	30	18.6	18.0	1150	30	18.0	1150	30	18.0	1150	30	18.0	1150	30	19.3									
0.12	12 430	2.7	26	0.63	1.06	1.7	1.4	1.6	4600	6300	4600	6300	6300	13	13	6300	13	6300	13	6300	13	6300	13	6300	13	6300	13	6300									
1.10	2850	3.7	65	0.85	2.87	4.5	1.6	1.8	40	18.3	900	700	900	44	25	24.4	900	44	24.4	900	44	24.4	900	44	24.4	900	44	25									
0.18	12 430	4.0	26	0.54	1.85	1.5	1.3	1.5	4000	6000	4000	6000	6000	13	13	6000	13	6000	13	6000	13	6000	13	6000	13	6000	13	6000									
1.5	2900	4.9	67	0.86	3.76	5.6	1.9	1.9	54	22	900	700	900	58	28	27	900	58	27	900	58	27	900	58	27	900	58	29									
0.25	12 440	5.4	36	0.46	2.18	1.8	1.7	1.8	3800	5000	3800	5000	5000	13	13	5000	13	5000	13	5000	13	5000	13	5000	13	5000	13	5000									
2	2900	6.6	74	0.88	4.43	6.5	2.1	2.0	98	30	800	—	800	107	40	39	800	107	39	800	107	39	800	107	39	800	107	42									
0.3	12 460	6.2	46	0.43	2.19	2.0	2.1	2.0	3400	3400	—	—	3400	20	20	3400	20	3400	20	3400	20	3400	20	3400	20	3400	20	3400									
3	2920	9.8	74	0.87	6.7	6.8	2.3	1.9	213	44	450	—	450	223	57	56	450	223	56	450	223	56	450	223	56	450	223	58									
0.5	12 470	10.2	51	0.43	3.3	2.0	1.7	1.6	3000	3000	—	—	3000	37	37	3000	37	3000	37	3000	37	3000	37	3000	37	3000	37	3000									
4	2920	13.1	75	0.89	8.6	5.9	2.4	2.3	270	53	400	—	400	280	66	65	400	280	65	400	280	65	400	280	65	400	280	67									
0.7	12 460	14.5	53	0.44	4.3	1.9	1.7	1.6	2800	2800	—	—	2800	37	37	2800	37	2800	37	2800	37	2800	37	2800	37	2800	37	2800									



4/8P

1500/750 min⁻¹ - S1

50 HZ

P _n kW		n min ⁻¹	M _n Nm	η %	cosφ	I _n 400V A	$\frac{I_s}{I_n}$	$\frac{M_s}{M_n}$	$\frac{M_a}{M_n}$	$\frac{J_m}{kgm^2} \times 10^{-4}$	IM B5 	G.S.-Bremse						G.S.-Bremse mit festem Luftspalt						W.S.-Bremse														
												FD			AFD			FA			FD			AFD			FA			FD			AFD			FA		
												Mod	Mb Nm	Z ₀ 1/h	NB	SB	J _m kgm ²	IM B5 	Mod	Mb Nm	Z ₀ 1/h	SB	J _m kgm ²	IM B5 	Mod	Mb Nm	Z ₀ 1/h	SB	J _m kgm ²	IM B5 	Mod	Mb Nm	Z ₀ 1/h	J _m kgm ²	IM B5 			
0.37	BN 80A	4	1400	2.5	63	0.82	1.03	3.3	1.4	1.4	8.2	FD 04	10	2300	3500	16.6	12.1	AFD 04	10	3500	7000	16.6	11.7	FA 04	10	3500	7000	16.6	12.0									
0.18		8	690	2.5	44	0.60	0.98	2.2	1.5	1.6			4500	7000																								
0.55	BN 80B	4	1390	3.8	65	0.86	1.42	3.8	1.7	1.6	9.9	FD 04	10	2200	2900	22	13.8	AFD 04	10	2900	6500	22	13.4	FA 04	10	2900	6500	22	13.7									
0.30		8	670	4.3	49	0.65	1.36	2.3	1.7	1.8			4200	6500																								
0.65	BN 90S	4	1390	4.5	73	0.85	1.51	4.0	1.9	1.9	13.6	FD 14	15	2300	2800	30	17.8	AFD 14	15	2800	6000	30	17.4	FA 14	15	2800	6000	30	17.7									
0.35		8	690	4.8	49	0.57	1.81	2.5	2.1	2.2			3500	6000																								
0.9	BN 90L	4	1370	6.3	73	0.87	2.05	3.8	1.8	1.8	15.1	FD 05	26	1700	2100	34	21	AFD 05	26	2100	4200	34	20.4	FA 05	26	2100	4200	34	22									
0.5		8	670	7.1	57	0.62	2.04	2.4	2.0	2.0			2500	4200																								
1.30	BN 100LA	4	1420	8.7	72	0.83	3.14	4.3	1.7	1.8	22	FD 15	40	1300	1700	86	28	AFD 15	40	1700	3400	86	27	FA 15	40	1700	3400	86	29									
0.70		8	700	9.6	58	0.64	2.72	2.8	1.8	1.8			2000	3400																								
1.8	BN 100LB	4	1420	12.1	69	0.87	4.3	4.2	1.6	1.7	25	FD 15	40	1200	1700	99	31	AFD 15	40	1700	2600	99	30	FA 15	40	1700	2600	99	32									
0.9		8	700	12.3	62	0.63	3.3	3.2	1.7	1.8			1600	2600																								
2.2	BN 112M	4	1440	14.6	77	0.85	4.9	5.3	1.8	1.8	32	FD 06S	60	—	1200	177	42	AFD 06S	60	1200	2000	177	41	FA 06S	60	1200	2000	177	43									
1.2		8	710	16.1	70	0.63	3.9	3.3	1.9	1.8			—	2000																								
3.6	BN 132S	4	1440	24	80	0.82	7.9	6.5	2.1	1.9	45	FD 56	75	—	1000	305	58	AFD 06	75	1000	1400	305	57	FA 06	75	1000	1400	305	59									
1.8		8	720	24	72	0.55	6.6	4.6	1.9	2.0			—	1400																								
4.6	BN 132M	4	1450	30	81	0.83	9.9	6.5	2.2	1.9	56	FD 06	100	—	1000	393	69	AFD 06	100	1000	1300	393	68	FA 07	100	1000	1300	393	74									
2.3		8	720	31	73	0.54	8.4	4.4	2.3	2.0			—	1300																								

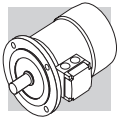

2P		3000 min ⁻¹ - S1																50 Hz								
		G.S.-Bremse																G.S.-Bremse mit festem Luftspalt				W.S.-Bremse				
		FD								AFD								FA								
P _n		n	M _n	IE1	η (100%)	η (75%)	η (50%)	cosφ	In 400V	Is / In	Ms / Mn	Ma / Mn	J _m x 10 ⁻⁴ kgm ²	IM B5	Mod	Mb	Z ₀ 1/h	J _m x 10 ⁻⁴ kgm ²	IM B5	Mod	Mb	Z ₀ 1/h	J _m x 10 ⁻⁴ kgm ²	IM B5		
0.18	M 05A 2	2730	0.63	○	59.9	56.9	51.9	0.77	0.56	3.0	2.1	2.0	2.0	3.2	FD 02	1.75	3900	4800	2.6	4.9	AFD 02	1.75	4800	4800	2.6	4.7
0.25	M 05B 2	2740	0.87	○	66.0	64.8	64.8	0.76	0.72	3.3	2.3	2.3	2.3	3.6	FD 02	1.75	3900	4800	3.0	5.3	AFD 02	1.75	4800	4800	3.0	5.1
0.37	M 05C 2	2800	1.26	○	69.1	66.8	66.8	0.78	0.99	3.9	2.6	2.6	3.3	4.8	FD 02	3.5	3600	4500	3.9	6.5	AFD 02	3.5	4500	4500	3.9	6.3
0.55	M 15D 2	2820	1.86	○	76.0	75.8	74.8	0.76	1.37	5.0	2.9	2.8	4.1	5.8	FD 03	5	2900	4200	5.3	8.5	AFD 03	5	4200	4200	5.3	8.2
0.75	M 15LA 2	2810	2.6	○	76.6	76.2	76.2	0.76	1.86	5.1	3.1	2.8	5.0	6.9	FD 03	5	1900	3300	6.1	9.6	AFD 03	7.5	3300	3300	6.1	9.3
1.1	M 25A 2	2800	3.8	●	76.4	76.2	75.0	0.81	2.57	4.8	2.8	2.4	9.0	8.8	FD 04	10	1500	3000	10.6	11.9	AFD 04	10	3000	3000	10.6	11.5
1.5	M 25B 2	2800	5.1	●	79.1	79.5	77.2	0.81	3.4	4.9	2.7	2.4	11.4	10.6	FD 04	15	1300	2600	13.0	9.9	AFD 04	15	2600	2600	13.0	9.5
2.2	M 35A 2	2880	7.3	●	82.7	82.1	81.0	0.80	4.8	6.3	2.9	2.7	24	15.5	FD 15	26	1100	2400	28	22	AFD 15	26	2400	2400	28	21.4
3	M 35LA 2	2860	10.0	●	81.5	81.3	77.4	0.79	6.7	5.6	2.6	2.2	31	18.7	FD 15	26	700	1600	35	25	AFD 15	26	1600	1600	35	24.4
4	M 35LB 2	2870	13.3	●	83.1	83.0	77.8	0.80	8.7	5.8	2.7	2.5	39	22	FD 15	40	450	900	43	28	AFD 15	40	900	900	43	27
5.5	M 45A 2	2890	18.2	●	84.7	84.5	81.2	0.84	11.2	5.9	2.6	2.2	101	33	FD 06	50	—	600	112	46	AFD 06	62	600	600	112	45
7.5	M 45B 2	2900	25	●	86.5	86.3	84.4	0.85	14.7	6.4	2.6	2.2	145	40	FD 06	50	—	550	154	53	AFD 06	62	550	550	154	52
9.2	M 45LA 2	2930	30	●	87.0	86.5	83.6	0.86	17.7	6.7	2.8	2.3	178	51	FD 56	75	—	430	189	64	AFD 06	75	430	430	189	63
11	M 45LC 2	2920	36	●	87.6	87.0	86.0	0.88	20.6	6.9	2.9	2.5	210	60												
15	M 55B 2	2930	49	●	89.6	89.4	88.0	0.86	28.1	7.1	2.6	2.3	340	70												
18.5	M 55C 2	2930	60	●	90.4	90.1	89.0	0.86	34	7.6	2.7	2.3	420	83												
22	M 55LA 2	2930	72	●	89.9	89.7	89.5	0.88	40	7.8	2.6	2.4	490	95												

○ = n.a. ● = IE1



4P **1500 min⁻¹ - S1** **50 Hz**

P _n kW	n min ⁻¹	M _n Nm	IE1	η (100%) %	η (75%) %	η (50%) %	cosφ	In 400V A	Is In %	Ms Mn %	Ma Mn %	J _m x 10 ⁻⁴ kgm ²	IM B5 Kg	G.S.-Bremse						G.S.-Bremse mit festem Luftspalt						W.S.-Bremse														
														FD			AFD			FA			FD			AFD			FA			FD			AFD			FA		
														Mod	Mb Nm	Z ₀ 1/h	IM B5 Kg	J _m x 10 ⁻⁴ kgm ²	IM B5 Kg	Mb Nm	Z ₀ 1/h	IM B5 Kg	Mod	Mb Nm	Z ₀ 1/h	IM B5 Kg	J _m x 10 ⁻⁴ kgm ²	IM B5 Kg	Mb Nm	Z ₀ 1/h	IM B5 Kg	Mod	Mb Nm	Z ₀ 1/h	IM B5 Kg	J _m x 10 ⁻⁴ kgm ²	IM B5 Kg	Mod	Mb Nm	Z ₀ 1/h
0.09	M 0B 4	1350	0.64	○	51.7	47.6	42.9	0.60	0.42	2.6	2.5	2.4	1.5	2.9	FD 02	1.75	10000	13000	2.6	4.9	AFD 02	1.75	13000	13000	2.6	4.7	FA 02	1.75	13000	13000	2.6	4.7								
0.12	M 05A 4	1350	0.85	○	59.8	56.2	47.0	0.62	0.47	2.6	1.9	1.8	2.0	3.2	FD 02	3.5	10000	13000	3.0	5.3	AFD 02	3.5	13000	13000	3.0	5.1	FA 02	3.5	13000	13000	3.0	5.1								
0.18	M 05B 4	1320	1.30	○	54.8	52.9	52.5	0.67	0.71	2.6	2.2	2.0	2.3	3.6	FD 02	3.5	7800	10000	3.9	6.5	AFD 02	3.5	10000	10000	3.9	6.3	FA 02	3.5	10000	10000	3.9	6.3								
0.25	M 05C 4	1340	1.78	○	65.3	65.0	57.9	0.69	0.80	2.7	2.1	1.9	3.3	4.8	FD 02	5	6000	9400	8.0	8.2	AFD 03	7.5	9400	9400	8.0	7.9	FA 03	5	9400	9400	8.0	7.9								
0.37	M 1SD 4	1370	2.6	○	66.8	66.7	63.0	0.76	1.05	3.7	2.0	1.9	6.9	5.5	FD 03	7.5	4300	8700	10.2	9.6	AFD 03	7.5	8700	8700	10.2	9.3	FA 03	7.5	8700	8700	10.2	9.3								
0.55	M 1LA 4	1380	3.8	○	69.0	68.9	68.8	0.74	1.55	4.1	2.3	2.3	9.1	6.9	FD 53	15	4100	7800	22	13.1	AFD 04	15	7800	7800	22	12.7	FA 04	15	7800	7800	22	13.0								
0.75	M 2SA 4	1400	5.1	●	75.0	74.5	69.3	0.78	1.85	4.9	2.7	2.5	20	9.2	FD 04	26	2800	4900	38	22	AFD 15	26	4900	4900	38	21.4	FA 15	26	4900	4900	38	23								
1.1	M 2SB 4	1400	7.5	●	76.4	76.2	70.4	0.78	2.66	5.1	2.8	2.5	25	10.6	FD 04	40	2600	4700	44	24	AFD 15	40	4700	4700	44	23.4	FA 15	40	4700	4700	44	24								
1.5	M 3SA 4	1410	10.2	●	79.6	80.5	79.3	0.77	3.5	4.6	2.1	2.1	34	15.5	FD 15	40	2400	4400	58	27	AFD 15	40	4400	4400	58	26	FA 15	40	4400	4400	58	28								
2.2	M 3LA 4	1410	14.9	●	81.1	81.4	79.9	0.75	5.2	4.5	2.2	2.0	40	17	FD 15	55	1300	65	65	29	—	—	—	—	—	—	—	—	—	—	—	—	—	—						
3	M 3LB 4	1410	20	●	82.6	83.8	83.7	0.77	6.8	5.0	2.3	2.2	54	21	FD 55	75	1050	223	223	55	AFD 06	75	1050	1050	223	54	FA 06	75	1050	1050	223	56								
4	M 3LC 4	1400	27	○	82.7	83.1	80.5	0.78	9.0	4.7	2.3	2.2	61	23	FD 56	100	950	280	280	64	AFD 06	100	950	950	280	63	FA 07	100	950	950	280	65								
5.5	M 4SA 4	1440	36	●	84.7	84.8	82.5	0.81	11.6	5.5	2.3	2.2	213	42	FD 06	150	900	342	342	73	AFD 07	150	900	900	342	71	FA 07	150	900	900	342	75								
7.5	M 4LA 4	1440	50	●	86.0	86.3	85.3	0.81	15.5	5.7	2.5	2.4	270	51	FD 07	150	850	382	382	81	AFD 07	150	850	850	382	79	FA 07	150	850	850	382	83								
9.2	M 4LB 4	1440	61	●	88.4	88.6	87.5	0.81	18.8	5.9	2.7	2.5	319	57	FD 07	200	750	725	725	115	—	—	—	—	—	—	—	—	—	—	—	—	—							
11	M 4LC 4	1440	73	●	87.6	87.8	86.0	0.81	22.4	6.0	2.7	2.5	360	65	FD 08	250	700	865	865	131	—	—	—	—	—	—	—	—	—	—	—	—	—							
15	M 5SB 4	1460	98	●	88.7	88.5	88.4	0.81	30.1	6.0	2.3	2.1	650	85	FD 08	250	700	865	865	131	—	—	—	—	—	—	—	—	—	—	—	—	—	—						
18.5	M 5LA 4	1460	121	●	89.3	89.5	89.2	0.81	37	6.2	2.6	2.5	790	101	FD 08	—	—	—	—	—	—	—	—	—	—	—	—	—	—	—	—	—	—	—						

○ = n.a. ● = IE1

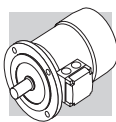

6P		1000 min ⁻¹ - S1																				50 Hz							
		G.S.-Bremsen										G.S.-Bremsen mit festem Luftspalt										W.S.-Bremsen							
		FD					IM B5					AFD					IM B5					FA							
P _n		n	M _n	IE1	η (100%)	η (75%)	η (50%)	cosφ	In	$\frac{I_s}{I_n}$	$\frac{M_s}{M_n}$	$\frac{M_a}{M_n}$	J _m x 10 ⁻⁴	IM B5	Mod	Mb	Z ₀	J _m x 10 ⁻⁴	IM B5	Mod	Mb	Z ₀	J _m x 10 ⁻⁴	IM B5	Mod	Mb	Z ₀	J _m x 10 ⁻⁴	
kW		min ⁻¹	Nm		%	%	%		A				kgm ²	kg		Nm	1/h	kgm ²	kg		Nm	1/h	kgm ²	kg		Nm	1/h	kgm ²	
0.09	M 05A 6	880	0.98	○	41.0	41.0	32.9	0.53	0.60	2.1	2.1	1.8	3.4	4.3	FD 02	3.5	9000	14000	4.0	6.0	AFD 02	3.5	14000	4.0	5.8	FA 02	3.5	14000	4.0
0.12	M 05B 6	870	1.32	○	45.0	44.0	41.8	0.60	0.64	2.1	1.9	1.7	3.7	4.6	FD 02	3.5	9000	14000	4.3	6.3	AFD 02	3.5	14000	4.3	6.1	FA 02	3.5	14000	4.3
0.18	M 15C 6	900	1.91	○	55.0	55.5	51.0	0.69	0.68	2.6	1.9	1.7	8.4	5.1	FD 03	5	8100	13500	9.5	7.8	AFD 03	5	13500	9.5	7.5	FA 03	5	13500	9.5
0.25	M 15D 6	900	2.7	○	62.0	58.5	51.4	0.71	0.82	2.6	1.9	1.7	10.9	6.3	FD 03	5	7800	13000	12	9.0	AFD 03	7.5	13000	12	8.7	FA 03	5	13000	12
0.37	M 15LA 6	910	3.9	○	66.0	60.0	53.3	0.69	1.17	3.0	2.4	2.0	12.9	7.3	FD 53	7.5	5100	9500	14	10.0	AFD 03	7.5	9500	14	9.7	FA 03	7.5	9500	14
0.55	M 25A 6	920	5.7	○	70.0	69.8	64.3	0.68	1.67	3.9	2.6	2.2	25	10.6	FD 04	15	4800	7200	27	14.5	AFD 04	15	7200	27	14.1	FA 04	15	7200	27
0.75	M 25B 6	920	7.8	●	70.0	70.0	64.4	0.65	2.38	3.8	2.5	2.2	28	11.5	FD 04	15	3400	6400	30	15.4	AFD 04	15	6400	30	15	FA 04	15	6400	30
1.1	M 35A 6	920	11.4	●	75.0	74.0	72.0	0.72	2.9	4.3	2.0	1.8	33	17	FD 15	26	2700	5000	37	23	AFD 15	26	5000	37	22.4	FA 15	26	5000	37
1.5	M 35LA 6	940	15.2	●	75.2	74.2	70.3	0.72	4.0	4.1	2.1	2.0	82	21	FD 15	40	1900	4100	86	27	AFD 15	40	4100	86	26	FA 15	40	4100	86
1.85	M 35LB 6	930	19.0	●	76.6	72.8	62.6	0.73	4.8	4.6	2.1	2.0	95	23	FD 15	40	1700	3600	99	29	AFD 15	40	3600	99	28	FA 15	40	3600	99
2.2	M 35LC 6	930	23	●	77.7	76.8	72.4	0.71	5.8	4.7	2.3	2.1	95	23	FD 55	55	—	1900	99	29	—	—	—	—	—	FA 15	55	1900	99
3	M 45A 6	940	30	●	79.7	77.0	75.1	0.76	7.1	5.1	1.9	1.8	216	34	FD 56	75	—	1400	226	47	AFD 06	75	1400	226	46	FA 06	75	1400	226
4	M 45LA 6	950	40	●	81.4	81.5	79.5	0.77	9.2	5.5	2.0	1.8	295	43	FD 06	100	—	1200	305	56	AFD 06	100	1200	305	55	FA 07	100	1200	305
5.5	M 45LB 6	945	56	●	83.1	80.9	79.1	0.78	12.2	6.1	2.1	1.9	383	54	FD 07	150	—	1050	406	70	AFD 07	150	1050	406	68	FA 07	150	1050	406
7.5	M 55A 6	955	75	●	85.0	85.0	84.8	0.81	15.7	5.9	2.2	2.0	740	69	FD 08	170	—	900	815	98	—	—	—	—	—	FA 08	170	900	800
11	M 55B 6	960	109	●	86.4	86.5	85.9	0.81	22.7	6.6	2.5	2.3	970	89	FD 08	200	—	800	1045	119	—	—	—	—	—	FA 08	200	800	1030

○ = n.a. ● = IE1

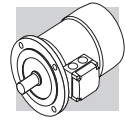

2/4P **3000/1500 min⁻¹ - S1** **50 Hz**

P _n	kW	n	M _n	η	cosφ	In	Is	In	In	G.S.-Bremse										G.S.-Bremse mit festem Luftspalt										W.S.-Bremse									
										FD					AFD					FA					FD					AFD					FA				
										IM B5	J _m	Z ₀	J _m	IM B5	Mod	Mb	Nm	SB	1/h	Z ₀	J _m	IM B5	J _m	Z ₀	J _m	IM B5	Mod	Mb	Nm	SB	1/h	Z ₀	J _m	IM B5	J _m	Z ₀	J _m	IM B5	Mod
0.20	M 05A	2	2700	0.71	55	0.82	0.64	0.64	3.5	2.1	1.9	2.9	4.1	FD 02	3.5	2200	2600	3.5	5.8	5.8	5.8	5.8	2600	5100	2600	5100	3.5	5.6	3.5	5.6	3.5	2600	5100	3.5	5.6	3.5	5.6		
0.15		4	1350	1.06	49	0.67	0.66	0.66	2.6	1.8	1.7				4000	5100						5100																	
0.28	M 1SB	2	2700	0.99	56	0.82	0.88	0.88	2.9	1.9	1.7	4.7	4.0	FD 03	3.5	2100	2400	5.8	6.7	6.7	6.7	2400	4800	2400	4800	5	6.4	5.8	6.4	3.5	2400	4800	5.8	6.4	5.8	6.4			
0.20		4	1370	1.39	59	0.68	1.02	1.02	3.1	1.8	1.7				3800	4800						4800																	
0.37	M 1SC	2	2740	1.29	56	0.82	1.16	1.16	3.5	1.8	1.8	5.8	4.7	FD 03	5	1400	2100	6.9	7.4	7.4	7.4	2100	4200	2100	4200	5	7.1	6.9	7.1	5	2100	4200	6.9	7.1	6.9	7.1			
0.25		4	1390	1.72	60	0.73	0.82	0.82	3.3	2.0	1.9				2900	4200						4200																	
0.45	M 1SD	2	2780	1.55	63	0.85	1.21	1.21	3.8	1.8	1.8	6.9	5.5	FD 03	5	1400	2100	8.0	8.2	8.2	8.2	2100	4200	2100	4200	5	7.9	8.0	7.9	5	2100	4200	8.0	7.9	8.0	7.9			
0.30		4	1400	2.0	63	0.74	0.93	0.93	3.8	2.1	1.9				2900	4200						4200																	
0.55	M 1LA	2	2800	1.9	73	0.79	1.38	1.38	4.2	2.0	1.8	9.1	6.9	FD 03	5	1600	2200	10.2	9.6	9.6	9.6	2200	4600	2200	4600	5	9.3	10.2	9.3	5	2200	4600	10.2	9.3	10.2	9.3			
0.37		4	1400	2.5	68	0.72	1.09	1.09	3.9	2.2	2.0				3300	4600						4600																	
0.75	M 2SA	2	2780	2.6	65	0.85	1.96	1.96	3.8	1.9	1.8	20	9.2	FD 04	10	1400	1600	22	13.1	13.1	13.1	1600	3600	1600	3600	10	12.7	22	12.7	10	1600	3600	22	12.7	22	13.0			
0.55		4	1400	3.8	68	0.81	1.44	1.44	3.9	1.7	1.7				2700	3600						3600																	
1.1	M 2SB	2	2730	3.9	65	0.86	2.84	2.84	3.9	2.0	1.9	25	10.7	FD 04	10	1200	1500	27	14.5	14.5	14.5	1500	3100	1500	3100	10	14.1	27	14.1	10	1500	3100	27	14.1	27	14.5			
0.75		4	1410	5.1	75	0.81	1.78	1.78	4.5	2.1	2.0				2300	3100						3100																	
1.5	M 3SA	2	2830	5.1	74	0.83	3.5	3.5	4.7	2.1	2.0	34	15.5	FD 15	26	700	1000	38	22	22	22	1000	2600	1000	2600	26	21.4	38	21.4	26	1000	2600	38	21.4	38	23			
1.1		4	1420	7.4	77	0.78	2.6	2.6	4.3	2.1	2.0				1600	2600						2600																	
2.2	M 3LA	2	2800	7.5	72	0.85	5.2	5.2	4.5	2.0	1.9	40	17	FD 15	26	600	900	44	24	24	24	900	2300	900	2300	26	23.4	44	23.4	26	900	2300	44	23.4	44	24			
1.5		4	1410	10.2	73	0.79	3.8	3.8	4.7	2.0	2.0				1300	2300						2300																	
3.5	M 3LB	2	2850	11.7	80	0.84	7.5	7.5	5.4	2.2	2.1	61	23	FD 15	40	500	900	65	29	29	29	900	2100	900	2100	40	28	65	28	40	900	2100	65	28	65	30			
2.5		4	1420	16.8	82	0.80	5.5	5.5	5.2	2.2	2.2				1000	2100						2100																	
4.8	M 4SA	2	2900	15.8	81	0.88	9.7	9.7	6.0	2.0	1.9	213	42	FD 06	50	—	400	233	55	55	55	400	233	400	233	62	54	233	54	50	400	233	55	54	233	56			
3.8		4	1430	25.4	81	0.84	8.1	8.1	5.2	2.1	2.1				—	950	950	223	55	55	55	950	950	950	950	75	54	223	54	75	350	223	55	54	223	56			
5.5	M 4SB	2	2890	18.2	80	0.87	11.4	11.4	5.9	2.4	2.0	213	42	FD 06	75	—	350	223	64	64	64	350	223	350	223	100	63	223	63	100	350	223	64	63	223	65			
4.4		4	1440	29	82	0.84	9.2	9.2	5.3	2.2	2.0				—	900	900	280	64	64	64	900	900	900	900	150	63	280	63	150	350	280	64	63	280	65			
7.5	M 4LA	2	2900	25	82	0.87	15.2	15.2	6.5	2.4	2.0	270	51	FD 06	100	—	350	280	73	73	73	350	280	350	280	300	71	280	71	300	350	280	73	71	300	342	75		
6		4	1430	40	84	0.85	12.1	12.1	5.8	2.3	2.1				—	950	950	342	73	73	73	950	800	950	800	150	71	342	71	150	300	342	73	71	300	342	75		
9.2	M 4LB	2	2920	30	83	0.86	18.6	18.6	6.0	2.6	2.2	319	57	FD 07	150	—	800	800	85	85	85	800	800	800	800	300	800	800	800	300	800	85	800	300	342	800	75		
7.3		4	1440	48	85	0.85	14.6	14.6	5.5	2.3	2.1				—	800	800	85	85	85	85	800	800	800	800	150	800	800	800	150	300	342	800	150	300	342	75		

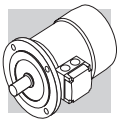

2/6P **3000/1000 min⁻¹ - S3 60/40%** **50 Hz**

P _n kW	n min ⁻¹	M _n Nm	η	cosφ	I _n 400V A	I _s I _n	M _s M _n	M _a M _n	J _m x 10 ⁻⁴ kgm ²	G.S.-Bremse				G.S.-Bremse mit festem Luftspalt				W.S.-Bremse								
										FD				AFD				FA								
										Mod	Mb Nm	Z _o 1/h	J _m x 10 ⁻⁴ kgm ²	IM B5 Kg	Mod	Mb Nm	Z _o 1/h	J _m x 10 ⁻⁴ kgm ²	IM B5 Kg	Mod	Mb Nm	Z _o 1/h	J _m x 10 ⁻⁴ kgm ²	IM B5 Kg		
0.25	M 1SA 2	2850	0.84	60	0.82	0.73	4.3	1.9	1.8	6.9	5.5	8.2	8.0	8.0	1700	1500	1700	8.0	7.9	FA 03	1.75	1700	8.0	8.0	7.9	
0.08	6	910	0.84	43	0.70	0.38	2.1	1.4	1.5	10000	13000	13000	13000	13000	13000	13000	13000	13000	13000	13000	13000	13000	13000	13000	13000	13000
0.37	M 1LA 2	2880	1.23	62	0.80	1.08	4.4	1.9	1.8	9.1	6.9	9.6	10.2	10.2	1300	1000	1300	10.2	9.3	FA 03	3.5	1300	10.2	10.2	9.3	
0.12	6	900	1.27	44	0.73	0.54	2.4	1.4	1.5	9000	11000	11000	11000	11000	11000	11000	11000	11000	11000	11000	11000	11000	11000	11000	11000	
0.55	M 2SA 2	2800	1.88	63	0.86	1.47	4.5	1.9	1.7	20	9.2	13.1	22	22	1800	1500	1800	22	12.7	FA 04	5	1800	22	22	13.0	
0.18	6	930	1.85	52	0.65	0.77	3.3	2.0	1.9	4100	6300	6300	6300	6300	6300	6300	6300	6300	6300	6300	6300	6300	6300	6300	6300	
0.75	M 2SB 2	2800	2.6	66	0.87	1.89	4.3	1.8	1.6	25	10.6	14.5	27	27	1700	1700	1900	27	14.1	FA 04	5	1900	27	27	14.4	
0.25	6	930	2.6	54	0.67	1.00	3.2	1.7	1.8	3800	6000	6000	6000	6000	6000	6000	6000	6000	6000	6000	6000	6000	6000	6000	6000	
1.1	M 3SA 2	2870	3.7	71	0.82	2.73	4.9	1.8	1.9	34	15.5	22	38	38	1000	1000	1300	38	21.4	FA 15	13	1300	38	38	23	
0.37	6	930	3.8	63	0.70	1.21	3.1	1.5	1.8	3500	5000	5000	5000	5000	5000	5000	5000	5000	5000	5000	5000	5000	5000	5000	5000	
1.5	M 3LA 2	2880	5.0	73	0.84	3.53	5.1	1.9	2.0	40	17	24	44	44	1000	1000	1200	44	23.4	FA 15	13	1200	44	44	24	
0.55	6	940	5.6	64	0.67	1.85	3.5	1.7	1.8	2900	4000	4000	4000	4000	4000	4000	4000	4000	4000	4000	4000	4000	4000	4000	4000	
2.2	M 3LB 2	2900	7.2	77	0.85	4.9	5.9	2.0	2.0	61	23	29	65	65	700	700	900	65	28	FA 15	26	900	65	65	30	
0.75	6	950	7.5	67	0.64	2.5	3.3	1.9	1.8	2100	3000	3000	3000	3000	3000	3000	3000	3000	3000	3000	3000	3000	3000	3000	3000	
3	M 4SA 2	2910	9.9	74	0.88	6.6	5.6	2.0	2.1	170	36	48	182	182	600	600	600	182	47	FA 06	37	600	182	182	50	
1.1	6	960	10.9	73	0.68	3.2	4.5	2.2	2.0	2200	2200	2200	2200	2200	2200	2200	2200	2200	2200	2200	2200	2200	2200	2200	2200	
4.5	M 4SB 2	2910	14.8	78	0.84	9.9	5.8	1.9	1.8	213	42	55	223	223	500	500	500	223	54	FA 06	37	500	223	223	56	
1.5	6	960	14.9	74	0.67	4.4	4.2	1.9	2.0	2100	2100	2100	2100	2100	2100	2100	2100	2100	2100	2100	2100	2100	2100	2100	2100	
5.5	M 4LA 2	2920	18.0	78	0.87	11.7	6.2	2.1	1.9	270	51	64	280	280	400	400	400	280	63	FA 06	62	400	280	280	65	
2.2	6	960	22	77	0.71	5.8	4.3	2.1	2.0	1900	1900	1900	1900	1900	1900	1900	1900	1900	1900	1900	1900	1900	1900	1900	1900	



2/8P **3000/750 min⁻¹ - S3 60/40%** **50 Hz**

P _n kW	n min ⁻¹	M _n Nm	η %	cosφ	In 400V A	Is In	Ms Mn	Ma Mn	J _m x 10 ⁻⁴ kgm ²	G.S.-Bremse					G.S.-Bremse mit festem Luftspalt					W.S.-Bremse								
										FD					AFD					FA								
										Mod	Mb Nm	Z _o 1/h	J _m x 10 ⁻⁴ kgm ²	IM B5 Kg	Mod	Mb Nm	Z _o 1/h	J _m x 10 ⁻⁴ kgm ²	IM B5 Kg	Mod	Mb Nm	Z _o 1/h	J _m x 10 ⁻⁴ kgm ²	IM B5 Kg	Mod	Mb Nm	Z _o 1/h	J _m x 10 ⁻⁴ kgm ²
0.37	M 1LA 2	2800	1.26	63	0.86	3.9	1.8	1.9	12.9	7.3	FD 03	3.5	1200	1300	14	10.0	AFD 03	5	1300	14	9.7	FA 03	3.5	1300	14	9.7		
0.09	8	670	1.28	34	0.75	1.8	1.4	1.5	13000	13000																		
0.55	M 2SA 2	2830	1.86	66	0.86	4.4	2.1	2.0	20	9.2	FD 04	5	1500	1800	22	13.1	AFD 04	5	1800	22	12.7	FA 04	5	1800	22	13.0		
0.13	8	690	1.80	41	0.64	2.3	1.6	1.7	8000	8000																		
0.75	M 2SB 2	2800	2.6	68	0.88	4.6	2.1	2.0	25	10.6	FD 04	10	1700	1900	27	14.5	AFD 04	10	1900	27	14.1	FA 04	10	1900	27	14.4		
0.18	8	690	2.5	43	0.66	2.3	1.6	1.7	4800	7300																		
1.1	M 3SA 2	2870	3.7	69	0.84	4.6	1.8	1.7	34	15.5	FD 15	13	1000	1300	38	22	AFD 15	13	1300	38	21.4	FA 15	13	1300	38	23		
0.28	8	690	3.9	44	0.56	2.3	1.4	1.7	3400	5000																		
1.5	M 3LA 2	2880	5.0	69	0.85	4.7	1.9	1.8	40	17	FD 15	13	1000	1200	44	24	AFD 15	13	1200	44	23.4	FA 15	13	1200	44	24		
0.37	8	690	5.1	46	0.63	2.1	1.6	1.6	3300	5000																		
2.4	M 3LB 2	2900	7.9	75	0.82	5.4	2.1	2.0	61	23	FD 15	26	550	700	65	29	AFD 15	26	700	65	28	FA 15	26	700	65	30		
0.55	8	700	7.5	54	0.58	2.6	1.8	1.8	2000	3500																		
3	M 4SA 2	2920	9.8	72	0.85	7.1	2.0	1.8	162	36	FD 56	37	—	600	182	48	AFD 06	37	600	182	47	FA 06	37	600	182	50		
0.75	8	710	10.1	61	0.64	3.0	1.7	1.8	—	—				3400	3400													
4	M 4SB 2	2870	13.3	73	0.84	9.4	2.3	2.4	213	42	FD 56	37	—	500	223	55	AFD 06	37	500	223	54	FA 06	37	500	223	56		
1	8	690	13.8	66	0.62	3.5	1.9	1.8	—	—				3500	3500													
5.5	M 4LA 2	2870	18.3	75	0.84	12.6	2.4	2.5	270	51	FD 06	50	—	400	280	64	AFD 06	62	400	280	63	FA 06	50	400	280	65		
1.5	8	690	21	68	0.63	5.1	1.9	1.9	—	—				2400	2400													

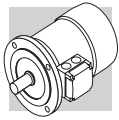

2/12P **3000/500 min⁻¹ - S3 60/40%** **50 Hz**

		G.S.-Bremse											G.S.-Bremse mit festem Luftspalt					W.S.-Bremse																	
		FD					AFD						FA																						
		P _n kW	n min ⁻¹	M _n Nm	η	cosφ	In 400V A	Is In	Ms Mn	Ma Mn	J _m x 10 ⁻⁴ kgm ²	IM B5 Kg	Mod	Mb Nm	Z _o 1/h	NB	SB	J _m x 10 ⁻⁴ kgm ²	IM B5 Kg	Mod	Mb Nm	Z _o 1/h	J _m x 10 ⁻⁴ kgm ²	IM B5 Kg											
0.55	M 2SA 2	2820	1.86	64	0.89	1.39	4.2	1.6	1.7	25	10.6	FD 04	5	1000	1300	27	14.5	AFD 04	5	1300	12000	FA 04	5	1300	12000	27	14.1	FA 04	5	1300	12000	27	14.4		
0.09	12	430	2.0	30	0.63	0.69	1.8	1.9	1.8					8000																					
0.75	M 3SA 2	2900	2.5	65	0.81	2.06	5.2	1.9	2.1	34	15.5	FD 15	13	700	900	38	22	AFD 15	13	900	7000	FA 15	13	900	7000	38	21.4	FA 15	13	900	7000	38	23		
0.12	12	460	2.5	33	0.43	1.22	1.9	1.3	1.6					5000																					
1.1	M 3LA 2	2850	3.7	65	0.85	2.87	4.5	1.6	1.8	40	17	FD 15	13	700	900	44	24	AFD 15	13	900	6000	FA 15	13	900	6000	44	23.4	FA 15	13	900	6000	44	24		
0.18	12	430	4.0	26	0.54	1.85	1.5	1.3	1.5					4000																					
1.5	M 3LB 2	2900	4.9	67	0.86	3.76	5.6	1.9	1.9	54	21	FD 15	13	700	900	58	27	AFD 15	13	900	5000	FA 15	13	900	5000	58	26	FA 15	13	900	5000	58	28		
0.25	12	440	5.4	36	0.46	2.18	1.8	1.7	1.8					3800																					
2	M 3LC 2	2850	6.7	70	0.84	4.9	4.9	1.8	1.7	61	23	FD 55	18	—	700	65	29	AFD 15	26	700	3500	FA 15	18	700	3500	65	28	FA 15	18	700	3500	65	30		
0.3	12	450	6.4	38	0.47	2.4	1.7	1.6	1.7					—																					
3	M 4SA 2	2920	9.8	74	0.87	6.7	6.8	2.3	1.9	213	42	FD 56	37	—	450	223	55	AFD 06	37	450	223	FA 06	37	450	223	223	54	FA 06	37	450	223	223	56		
0.5	12	470	10.2	51	0.43	3.3	2.0	1.7	1.6					—	3000																				
4	M 4LA 2	2920	13.1	75	0.89	8.6	5.9	2.4	2.3	270	51	FD 56	37	—	400	280	64	AFD 06	37	400	280	FA 06	37	400	280	280	63	FA 06	37	400	280	280	65		
0.7	12	460	14.5	53	0.44	4.3	1.9	1.7	1.6					—	2800																				



M19 MOTORENABMESSUNGEN BN-M

BN - IM B5

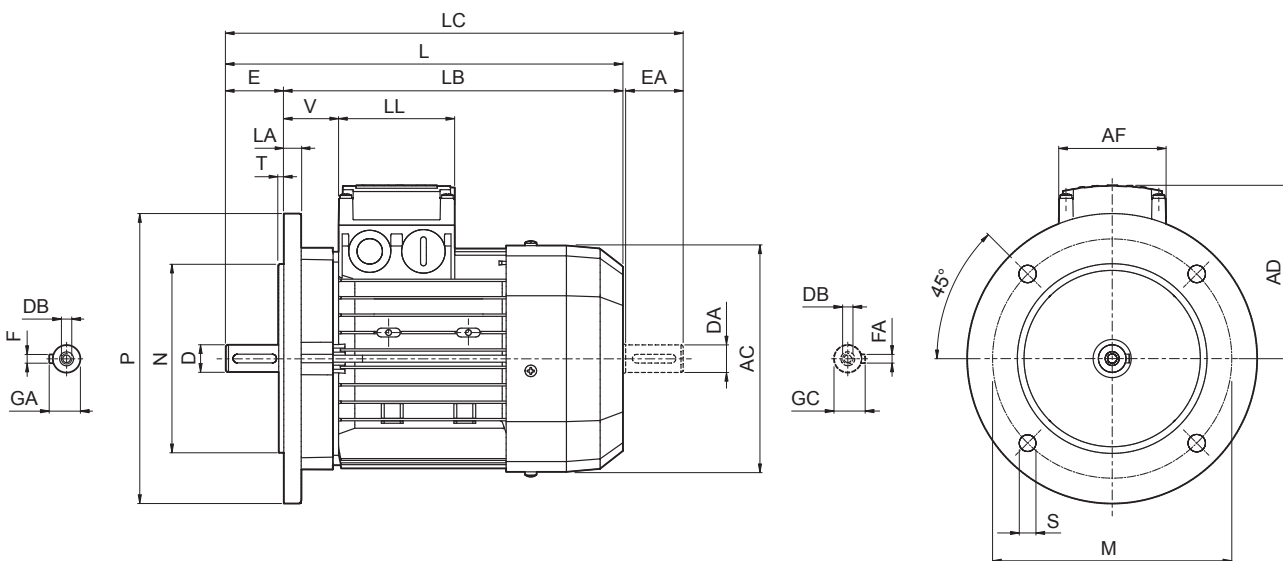

BN-M

	Welle					Flansch					Motor								
	D DA	E EA	DB	GA GC	F FA	M	N	P	S	T	LA	AC	L	LB	LC	AD	AF	LL	V
BN 56	9	20	M3	10.2	3	100	80	120	7	3	8	110	185	165	207	91	74	80	34
BN 63	11	23	M4	12.5	4	115	95	140	9.5		10	121	207	184	232	95			26
BN 71	14	30	M5	16	5	130	110	160			11.5	11.5	138	249	219	281			108
BN 80	19	40	M6	21.5	6	165	130	200	11.5	3.5	156	274	234	315	119	193	118	118	38
BN 90	24	50	M8	27	8						176	326	276	378	133				44
BN 100	28	60	M10	31	8	215	180	250	14	4	14	195	367	307	429	142	98	98	50
BN 112											15	219	385	325	448	157			52
BN 132											16	258	493	413	576	193			118
BN 160 MR	42 38 (1)	110 80 (1)	M16 M12 (1)	45 41 (1)	12 10 (1)	300	250	350	18.5	5	15	310	596	486	680	245	187	187	51
BN 160 M											15	310	596	486	680	245			51
BN 160 L											15	310	596	486	680	245			51
BN 180 M	48 38 (1)	110 110 (1)	M16 M12 (1)	51.5 41 (1)	14 10 (1)	350	300	400	18.5	5	18	348	708	598	823	261	187	187	52
BN 180 L	48 42 (1)		M16 M16 (1)	51.5 45 (1)	14 12 (1)						18	348	708	598	823	261			52
BN 200 L	55 42 (1)		M20 M16 (1)	59 45 (1)	16 12 (1)						18	348	722	612	837	261			66

HINWEIS:

1) Diese Maße betreffen das zweite Wellenende.



BN - IM B14

BN-M

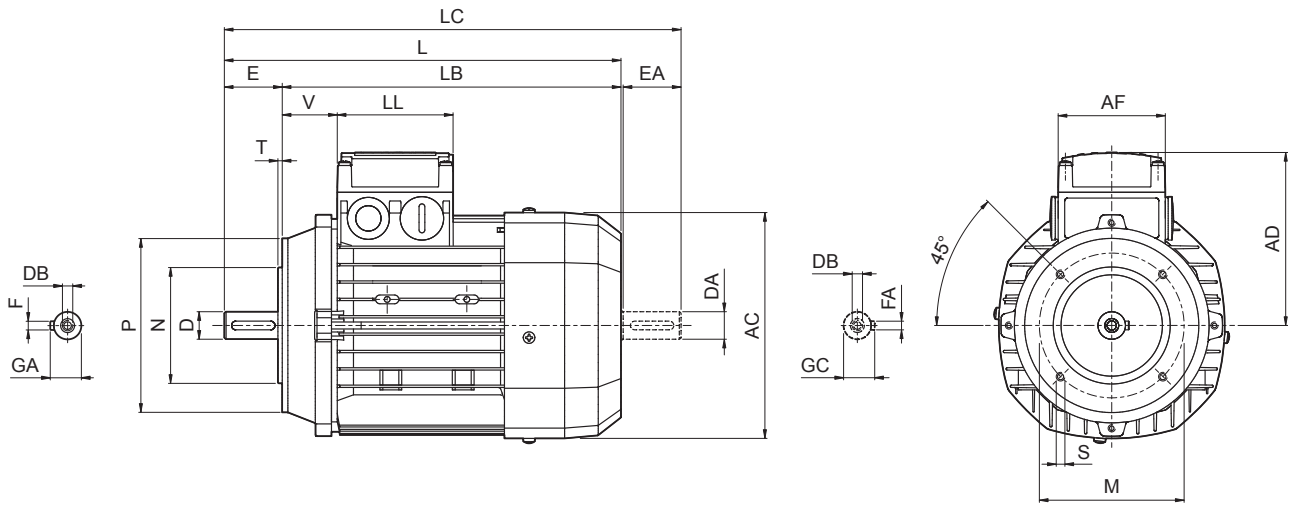

	Welle					Flansch					Motor							
	D DA	E EA	DB	GA GC	F FA	M	N	P	S	T	AC	L	LB	LC	AD	AF	LL	V
BN 56	9	20	M3	10.2	3	65	50	80	M5	2.5	110	185	165	207	91	74	80	34
BN 63	11	23	M4	12.5	4	75	60	90			121	207	184	232	95			26
BN 71	14	30	M5	16	5	85	70	105	M6		138	249	219	281	108			37
BN 80	19	40	M6	21.5	6	100	80	120		3	156	274	234	315	119	38		
BN 90	24	50	M8	27	8	115	95	140	M8		3.5	176	326	276	378	133	98	98
BN 100	28	60	M10	31		130	110	160		195		367	307	429	142	50		
BN 112					219	385	325	448	157	52								
BN 132	38	80	M12	41	10	165	130	200	M10	4	258	493	413	576	193	118	118	58



BN_FD ; BN_AFD - IM B5

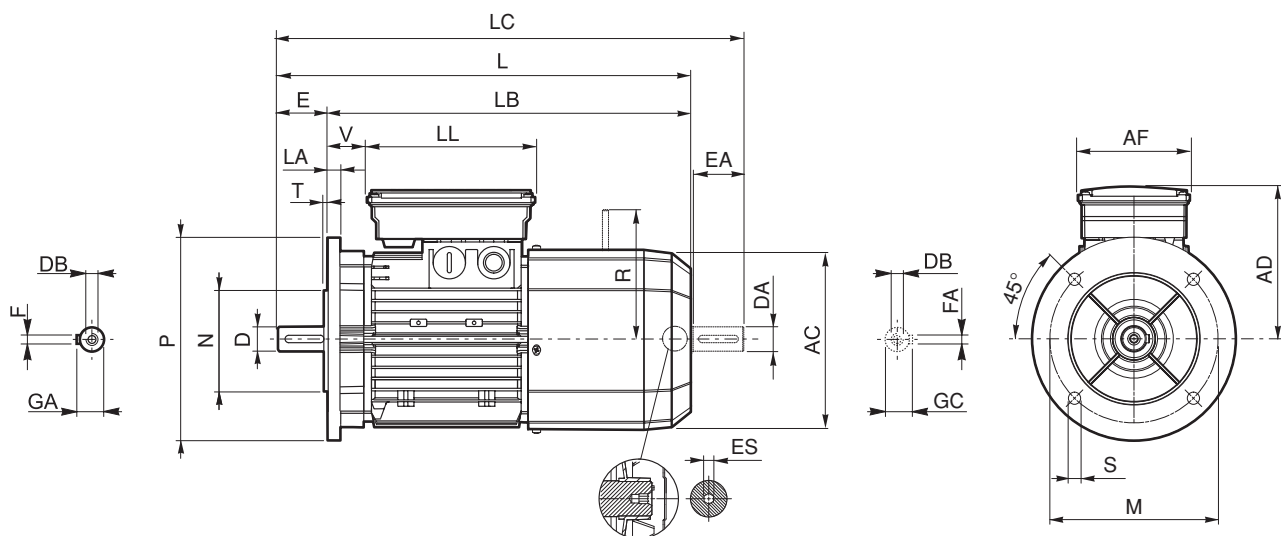

BN-M

	Welle					Flansch					Motor										
	D DA	E EA	DB	GA GC	F FA	M	N	P	S	T	LA	AC	L	LB	LC	AD	AF	LL	V	R	ES
BN 63	11	23	M4	12.5	4	115	95	140	9.5	3	10	121	272	249	297	122	98	133	14	96	5
BN 71	14	30	M5	16	5	130	110	160	9.5	3.5		138	310	280	342	135			110	165	
BN 80	19	40	M6	21.5	6	165	130	200	11.5		4	156	346	306	388	146	110	165			41
BN 90 S	24	50	M8	27	8					176		409	359	461	149	146			110	165	39
BN 90 L																					
BN 100	28	60	M10	31	8	215	180	250	14	4	14	195	458	398	521	158	110	165	62	160	6
BN 112											15	219	484	424	547	173			165	73	
BN 132	38	80	M12	41	10	265	230	300	14	4	20	258	603	523	686	210	140	188	46	204 (2)	6
BN 160 MR	42	110	M16	45	12	300	250	350			18.5		5	15	310				736	626	
BN 160 M	38 (1)	80 (1)	M12 (1)	41 (1)	10 (1)																
BN 160 L	42	110	M16	45	12	300	250	350	18.5	5	15	310	780	670	864	245	187	187	51	266	—
BN 180 M	48			41 (1)	10 (1)														51.5	14	
BN 180 L	48	110	M16	51.5	14	350	300	400	18.5	5	18	348	866	756	981	261	187	187	52	305	
BN 200 L	42 (1)	110 (1)	M20	59	16								45 (1)	12 (1)	878				768	993	64

HINWEIS:

- 1) Diese Maße betreffen das zweite Wellenende.
- 2) Für Bremse FD07, Maß R=226.

Der Sechskant ES ist bei der Option PS nicht vorhanden.



BN_FD ; BN_AFD - IM B14

BN-M

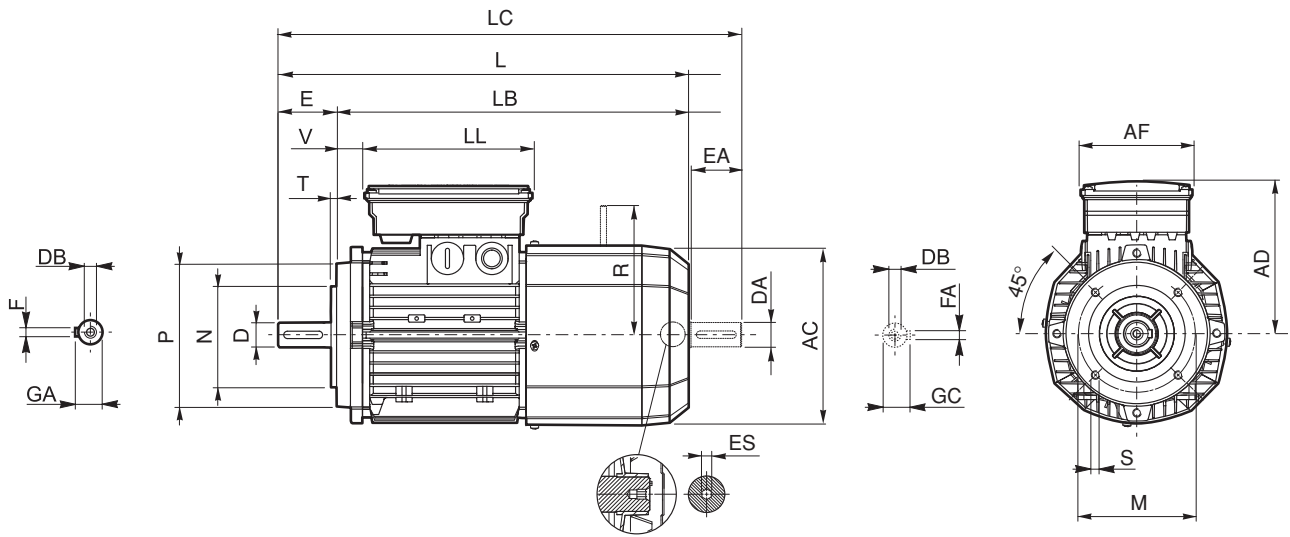

	Welle					Flansch					Motor									
	D DA	E EA	DB	GA GC	F FA	M	N	P	S	T	AC	L	LB	LC	AD	AF	LL	V	R	ES
BN 63	11	23	M4	12.5	4	75	60	90	M5	2.5	121	272	249	297	122	98	133	14	96	5
BN 71	14	30	M5	16	5	85	70	105	M6		138	310	280	342	135			25	103	
BN 80	19	40	M6	21.5	6	100	80	120			156	346	306	388	146			41	129	
BN 90 S	24	50	M8	27	8	115	95	140	M8	3	176	409	359	461	110	165	39	129	6	
BN 90 L																				146
BN 100	28	60	M10	31		130	110	160		3.5	195	458	398	521			158	62		199
BN 112											219	484	424	547			173	73		199
BN 132	38	80	M12	41	10	165	130	200	M10	4	258	603	523	686	210	140	188	46	204 (1)	

HINWEIS:

1) Für Bremse FD07, Maß R=226.

Der Sechskant ES ist bei der Option PS nicht vorhanden.



BN_FA - IM B5

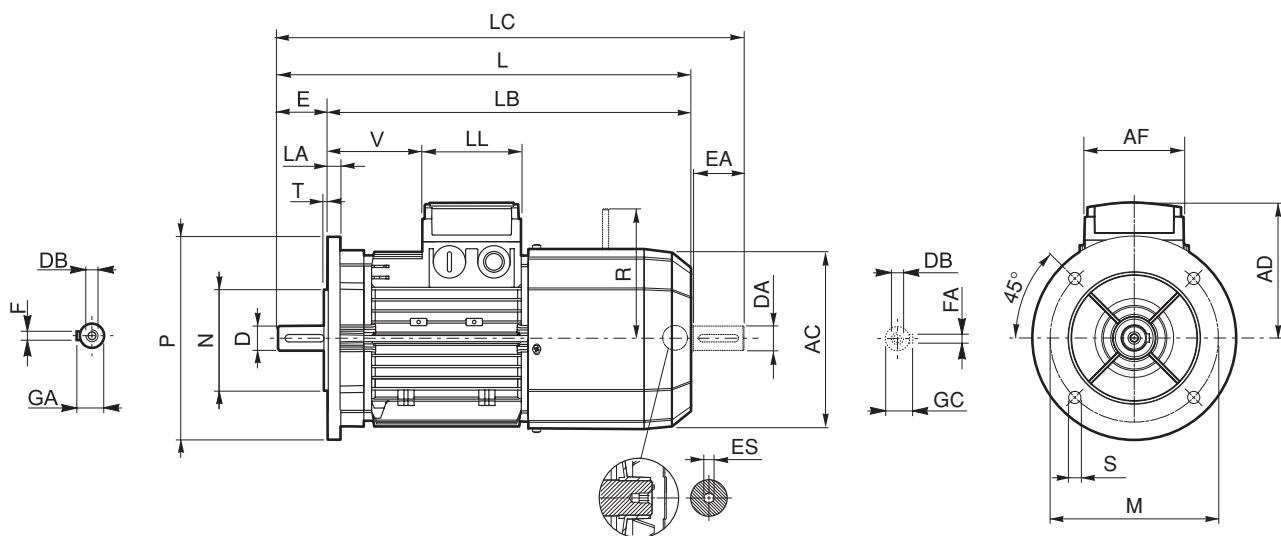

BN-M

	Welle					Flansch					Motor										
	D DA	E EA	DB	GA GC	F FA	M	N	P	S	T	LA	AC	L	LB	LC	AD	AF	LL	V	R	ES
BN 63	11	23	M4	12.5	4	115	95	140	9.5	3	10	121	272	249	297	95	74	80	26	116	5
BN 71	14	30	M5	16	5	130	110	160				138	310	280	342	108			68	124	
BN 80	19	40	M6	21.5	6	165	130	200	11.5	3.5	11.5	156	346	306	388	119	98	98	83	134	6
BN 90	24	50	M8	27	176							409	359	461	133	95			160		
BN 100	28	60	M10	31	8	215	180	250	14	4	14	195	458	398	521	142	119	128	198	200 (2)	
BN 112												15	219	484	424	547					157
BN 132	38	80	M12	41	10	265	230	300	18.5	5	15	20	258	603	523	686	210	140	188	46	217
BN 160 MR	42	110	M16 M12 (1)	45 41 (1)	12 10 (1)	300	250	350				18.5		5	15	258	672	562	755	193	118
BN 160 M									310	736	626		820			245	187	187	51	247	
BN 160 L																					780
BN 180 M									51.5 41 (1)	14 10 (1)	—										

HINWEIS:

- 1) Diese Maße betreffen das zweite Wellenende.
- 2) For FA07 brake value R=217.

Die Abmessungen des Klemmkastens der Motoren BN ... FAAD, AF, LL und V in Bezug auf die separate Spannungsversorgung (Option SA) stimmen mit den Abmessungen der entsprechenden Motoren BN...FD und AFD überein.

ES hexagon is not supplied with PS option.



BN_FA - IM B14

BN-M

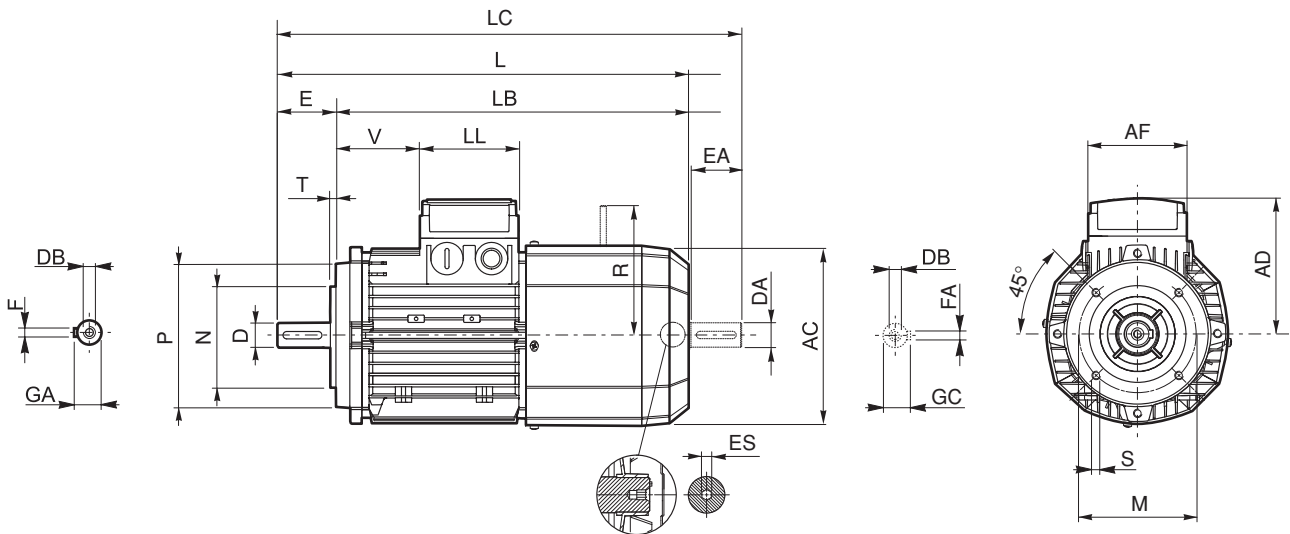

	Welle					Flansch					Motor									
	D DA	E EA	DB	GA GC	F FA	M	N	P	S	T	AC	L	LB	LC	AD	AF	LL	V	R	ES
BN 63	11	23	M4	12.5	4	75	60	90	M5	2.5	121	272	249	119	95	74	80	26	116	5
BN 71	14	30	M5	16	5	85	70	105	M6		138	310	280	342	108			68	124	
BN 80	19	40	M6	21.5	6	100	80	120		3	156	346	306	388	119			83	134	
BN 90	24	50	M8	27	8	115	95	140	M8		3.5	176	409	359	461	133	98	98	95	160
BN 100	28	60	M10	31		130	110	160		195		458	398	521	142	119			198	
BN 112											219	484	424	547	157	128			198	
BN 132	38	80	M12	41	10	165	130	200	M10	4	258	603	523	686	210	140	188	46	200 (1)	

N.B.:

1) For FA07 brake value R=217.

Die Abmessungen des Klemmkastens der Motoren BN ... FA AD, AF, LL und V in Bezug auf die separate Spannungsversorgung (Option SA) stimmen mit den Abmessungen der entsprechenden Motoren BN...FD und AFD überein.

ES hexagon is not supplied with PS option.



M

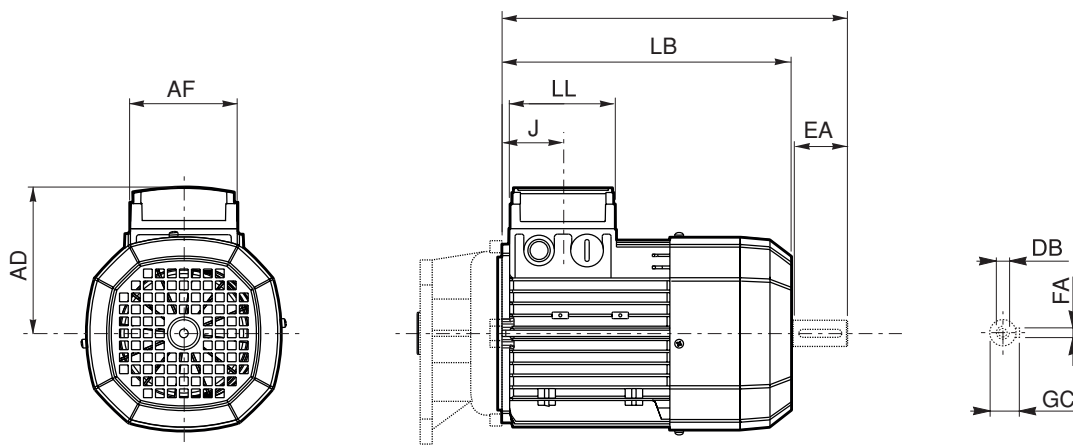

BN-M

	Zweite Wellenende					Motor						
	DA	EA	DB	FA	GC	AC	LB	LC	AF	LL	J	AD
M 0	9	20	M3	3	10.2	110	133	155	74	80	42	91
M 05	11	23	M4	4	12.5	121	165	191			48	95
M 1	14	30	M5	5	16	138	187	219			45	108
M 2 S	19	40	M6	6	21.5	156	202	245			44	119
M 3 S	28	60	M10	8	31	195	230	293	98	98	53.5	142
M 3 L							262	325				
M 4	38	80	M12	10	41	258	361	444	118	118	64.5	193
M 4 LC							396	479				
M 5 S						310	418	502	187	187	77	245
M 5 L							462	546				



M_FD ; M_AFD

BN-M

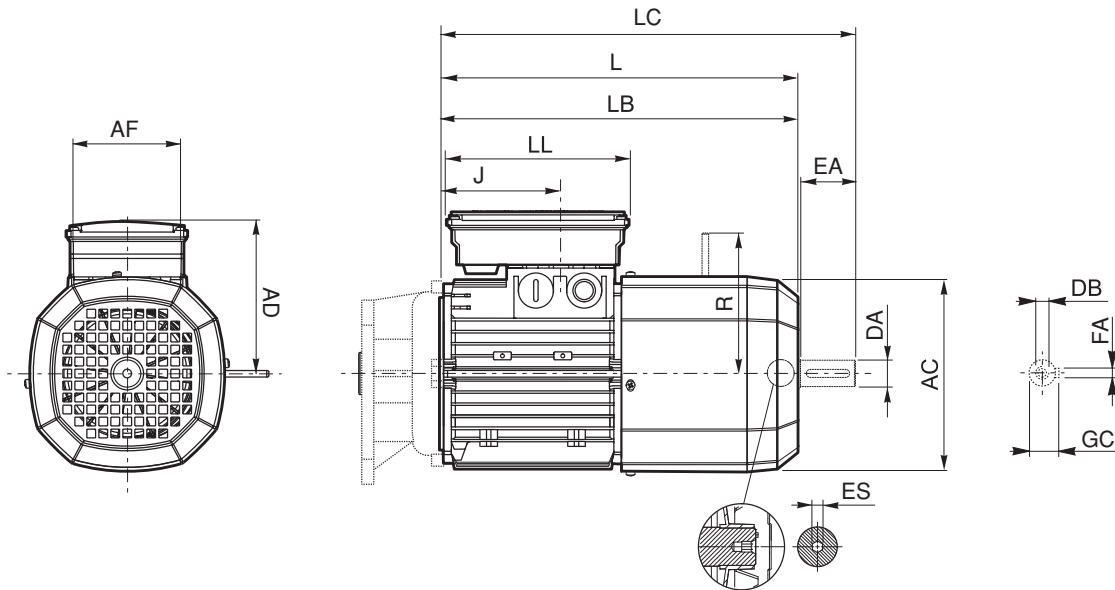

	Zweite Wellenende					Motor								
	DA	EA	DB	FA	GC	AC	LB	LC	AF	LL	J	AD	R	ES
M 05	11	23	M4	4	12.5	121	231	256	98	133	48	122	96	5
M 1	14	30	M5	5	16	138	248	280			73	135	103	
M 2 S	19	40	M6	6	21.5	156	272	314			88	146	129	
M 3 S	28	60	M10	8	31	195	326	389	110	165	124.5	158	160	6
M 3 L							353	416						
M 4	38	80	M12	10	41	258	470	553	140	188	185.5	210	204 (1)	
M 4 LC							495	578			64.5		226	
M 5 S						310	558	642	187	187	77	245	266	—
M 5 L	602	686												

HINWEIS:

1) Für Bremse FD07, Maß R=226.

Der Sechskant ES ist bei der Option PS nicht vorhanden.



M_FA

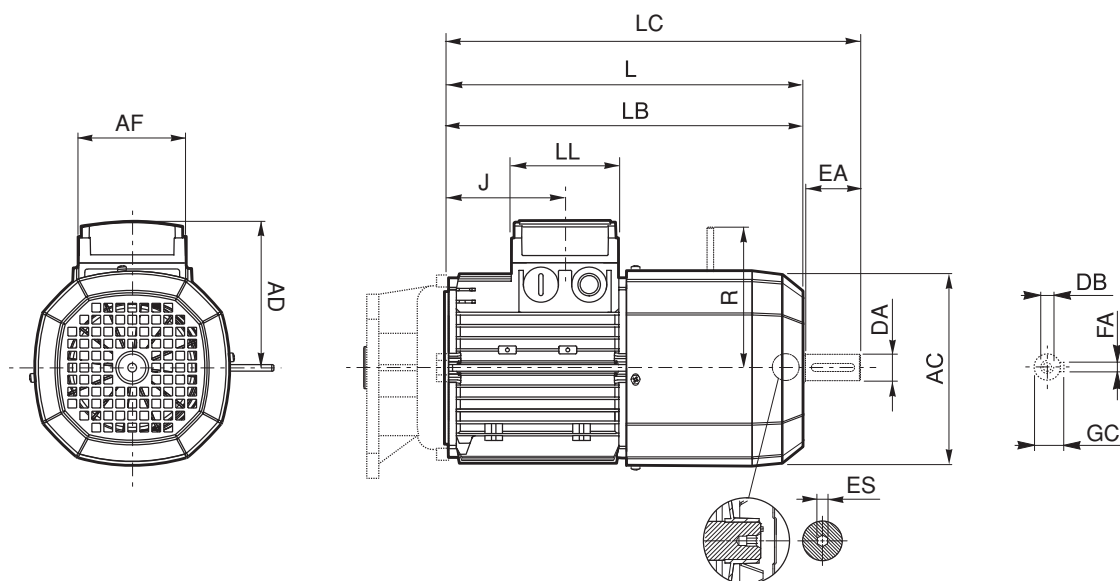

BN-M

	Zweite Wellenende					Motor									
	DA	EA	DB	FA	GC	AC	LB	LC	AF	LL	J	AD	R	ES	
M 05	11	23	M4	4	12.5	121	231	256	74	80	48	95	116	5	
M 1	14	30	M5	5	16	138	248	280			73	108	124		
M 2 S	19	40	M6	6	21.5	156	272	314			88	119	134		
M 3 S	28	60	M10	8	31	195	326	389	98	98	124.5	142	160	6	
M 3 L							353	416							
M 4	38	80	M14	10	41	258	470	553	140	188	185.5	210	200 (1)		
M 4 LC							495	578			64.5		217		
M 5 S			M12			310	558	642	187	187	77	245	247		—
M 5 L															

HINWEIS:

1) Für Bremse FA07, Maß R=217.

Die Abmessungen des Klemmkastens der Motoren M ...FAAD, AF, LL und V in Bezug auf die separate Spannungsversorgung (Option SA) stimmen mit den Abmessungen der entsprechenden Motoren M...FD und AFD überein.

Der Sechskant ES ist bei der Option PS nicht vorhanden.



LISTE DER ÄNDERUNGEN

BR_CAT_VFW_IE2-IE3_DEU_R03_0	
	Beschreibung
...	Zusätzliche Informationen zu IE3 Motoren.
40...66	Aktualisiertes Kapitel "Getriebemotoren-Auswahltabellen".
194...281	Neues Kapitel "Elektrische Motoren"

2015.07.06

Diese Veröffentlichung annulliert und ersetzt jede vorhergehende Ausgabe oder Revision. BONFIGLIOLI behält sich das Recht vor, Änderungen ohne vorherige Informationen durchzuführen.



Seit 1956 plant und realisiert Bonfiglioli innovative und zuverlässige Lösungen für die Leistungsüberwachung und -übertragung in industrieller Umgebung und für selbstfahrende Maschinen sowie Anlagen im Rahmen der erneuerbaren Energien.

HEADQUARTERS

Bonfiglioli Riduttori S.p.A.
Via Giovanni XXIII, 7/A
40012 Lippo di Calderara di Reno
Bologna (Italy)

tel: +39 051 647 3111
fax: +39 051 647 3126
bonfiglioli@bonfiglioli.com
www.bonfiglioli.com

BR_CAT_VFW_IE2-IE3_DEU_R03_0

