



***Radio Remote Control  
M880  
User's Manual***

# CONTENTS

---

<b>CONTENTS</b> .....	<b>2</b>
<b>INTRODUCTION</b> .....	<b>4</b>
<b>1. IDENTIFICATION DATA</b> .....	<b>5</b>
1.1. DOCUMENTATION .....	7
<b>2. CONVENTIONS USED IN THIS MANUAL</b> .....	<b>7</b>
<b>3. CAUTION</b> .....	<b>7</b>
3.1. RISK ANALYSIS.....	7
3.2. APPLICATIONS.....	7
<b>4. SIGNIFICANCE OF THE SYMBOLS IN LABELS</b> .....	<b>8</b>
<b>5. FCC-REGULATORY INFORMATION (2,4 GHZ RADIO MODULE)</b> .....	<b>8</b>
<b>6. PREVENTIVE MAINTENANCE</b> .....	<b>9</b>
6.1. ROUTINE MAINTENANCE TO BE CARRIED OUT BY THE OPERATOR.....	9
6.2. MAINTENANCE AND INTERNAL CHECKS.....	9
<b>7. INSTALLING THE RADIO REMOTE CONTROL</b> .....	<b>10</b>
7.1. RECEIVING UNIT DIMENSIONS AND DRILLING DIAGRAM .....	11
7.2. CONNECTING THE RECEIVER.....	12
7.3. INSTALLING THE EXTERNAL ANTENNA .....	13
7.4. STOP (E-STOP).....	14
7.5. SAFETY ENABLE (S-ENABLE) .....	14
7.6. BASIC FUNCTIONS BOARD PCB201 (DC) / PCB231 (AC) (SERVICE CARD).....	16
7.7. CONNECTION DIAGRAMS OF H RECEIVERS.....	16
7.8. HDC (PCB200) RECEIVER WITH ANALOG OUTPUT CARDS AND DATA FEEDBACK CARD .....	17
7.9. HAC (PCB230) RECEIVER WITH ANALOG OUTPUT CARDS AND DATA FEEDBACK CARDS .....	18
7.10. POWER SUPPLY CONNECTIONS OF HDC AND HAC RECEIVERS.....	19
7.11. ANALOG COMMAND BOARD (PCB261).....	20
7.12. LOGIC BOARD (PCB260).....	21
7.13. DATA FEEDBACK CARD (PCB262) .....	22
7.14. RELAY CARDS .....	23
7.15. BOARDS WITH SOLID STATE RELAYS (MOSFET).....	25
7.16. POTENTIOMETER CARD (M880DT2).....	26
7.17. CONNECTION DIAGRAMS FOR L RECEIVERS.....	27
7.18. M880 LDC VERSION (PCB100).....	27
7.19. M880 LAC VERSION (PCB130) .....	28
7.20. RELAY BOARD FOR M880 LAC AND M880 LDC RECEIVERS.....	29
7.21. OTHER COMMAND BOARDS FOR M880 LDC.....	30
7.22. CONNECTION DIAGRAMS FOR M RECEIVERS .....	31
7.23. M880 MAC VERSION (PCB300) .....	31
7.24. SERIAL DATA TRANSMISSION.....	32
7.25. USER SERIAL (RS232/RS485).....	32
7.26. SERIAL CONNECTION CABLE.....	32
<b>8. USING THE RADIO REMOTE CONTROL</b> .....	<b>33</b>
8.1. SAFETY RULES.....	33
8.2. POWERING AND STARTING THE RADIO REMOTE CONTROL.....	33
8.3. THE STOP FUNCTION .....	33
8.4. TURNING OFF THE REMOTE CONTROL.....	34
8.5. AUTO POWER-OFF (TIME-OUT).....	34
8.6. TRANSMITTER INDICATOR LEDs.....	34
8.7. TRANSMITTING UNIT POWER SUPPLY.....	36
8.8. BATTERY STATUS OF CHARGE .....	36
8.9. CHANGING AND CHARGING THE BATTERY .....	36
<b>9. CHANGING THE OPERATING FREQUENCY</b> .....	<b>37</b>
9.1. INITIAL CONDITIONS FOR THE FREQUENCY CHANGE.....	37
9.2. FREQUENCY CHANGE PROCEDURE.....	37

9.3.	AVAILABLE FREQUENCIES (433-434 MHz RADIO MODULE) .....	38
9.4.	AVAILABLE FREQUENCIES (2,4 GHz RADIO MODULE).....	39
<b>10.</b>	<b>DSC (DYNAMIC SPEED CONTROL) OPTION .....</b>	<b>39</b>
<b>11.</b>	<b>TROUBLESHOOTING .....</b>	<b>40</b>
11.1.	MALFUNCTIONS IN THE TRANSMITTER'S STOP CIRCUIT .....	41
11.2.	PASSIVE EMERGENCY .....	41
11.3.	TECHNICAL ASSISTANCE .....	41
<b>12.</b>	<b>TECHNICAL SPECIFICATIONS.....</b>	<b>42</b>
12.1.	CE RADIO MODULE (433-434 MHz) .....	42
12.2.	CE, FCC, IC, ARIB RADIO MODULE (2,4 GHz).....	42
12.3.	TRANSMITTER.....	43
12.4.	M880 HDC / M880 HAC RECEIVERS .....	45
12.5.	M880 LDC / M880 LAC RECEIVERS .....	47
12.6.	M880 MAC RECEIVERS .....	49
12.7.	CB3600-AC, CB3600-DC BATTERY CHARGER FOR THOR2, ZEUS2, ARES2 AND KRON TRANSMITTERS.....	50
12.8.	CB36NIMH BATTERY CHARGER FOR THOR2, ZEUS2, ARES2 AND KRON TRANSMITTERS.....	51
12.9.	CB36NIMH G4 - BATTERY CHARGER M880 G4L AND M880 G4S TRANSMITTERS.....	52
12.10.	CB37LION BATTERY CHARGER FOR WAVE2 TRANSMITTERS .....	53
<b>13.</b>	<b>RADIO REMOTE CONTROL SPARE PARTS LIST.....</b>	<b>54</b>
13.1.	TRANSMITTING UNITS AND BATTERY CHARGER .....	54
13.2.	HDC RECEIVER .....	54
13.3.	HAC RECEIVER.....	54
13.4.	LDC RECEIVER.....	54
13.5.	LAC RECEIVER .....	54
13.6.	MAC RECEIVER .....	55
<b>14.</b>	<b>DISPOSAL (EU ZONE).....</b>	<b>55</b>
<b>15.</b>	<b>ANNEXES .....</b>	<b>55</b>

## INTRODUCTION

After a decade of success and of satisfaction for IMET customers, the M550 series passes the baton to the new **M880** family. IMET designs and manufactures industrial safety radio remote controls since 1988.

The **M880** series features advanced radio remote controls with new technical features that facilitate use by giving great flexibility to the user.

The IMET range of solutions is vast, but it continues to evolve depending on the technology trends of the modern world. In fact, it is surprising how today, new applications in every imaginable field of production see the light. Any existing machinery or of new conception, could have the need, on the user side, to make it radio-remote controllable.



### Transmitters

The advantages of the use of the remote control are: safety, first and foremost, to prevent the potential risks of job; comfort, and not least, the excellent cost / benefit ratio.

Consider, among other things, the best point of view and the mobility which gives the radio control. IMET has developed over the years, reliable remote controls, which allow the operator to have a total control of the work situation. Furthermore, IMET radio remote controls take into account the ergonomics, the size and the weight, to ensure that the user can work in a comfortable and safe way.

### L Receiver



IMET radio remote controls can be used in various applications in the fields of mobile machines and the industry. Applications vary from the simplest, with the few digital ON/OFF controls, to the most complex, with many mixed commands, digital and analog, plus data-feedback. They perfectly interface themselves, of course, with modern industrial automation systems and PLCs with the CANopen and CANbus, protocols, etc.

IMET radio remote controls have an easily interpretable identification code, to allow their immediate recognition.

The housings are made of impact resistant plastic to withstand the toughest conditions of use, keeping intact in time the reliability and functionality.

Rechargeable batteries are hermetic and removable and ensure continuous operation for long shifts, or even under severe weather conditions.

### H Receiver



The **M880** series features an automatic frequency change, also. This property allows to position oneself on free channels, thus avoiding interference with other devices in the vicinity. The operator can decide, in any case, to set the transmission on a fixed channel, as it is for the M550 series.

Each transmitter is designed and manufactured in compliance with the directives and the sectorial European standards and meets the highest safety levels, such as the PLe for the STOP circuit. The radio transmission is continuous and encoded, where only those commands coming from its matched unwanted activations by other transmitters in the

### M Receiver



each receiver recognizes transmitter, thus avoiding area.

# 1. Identification data

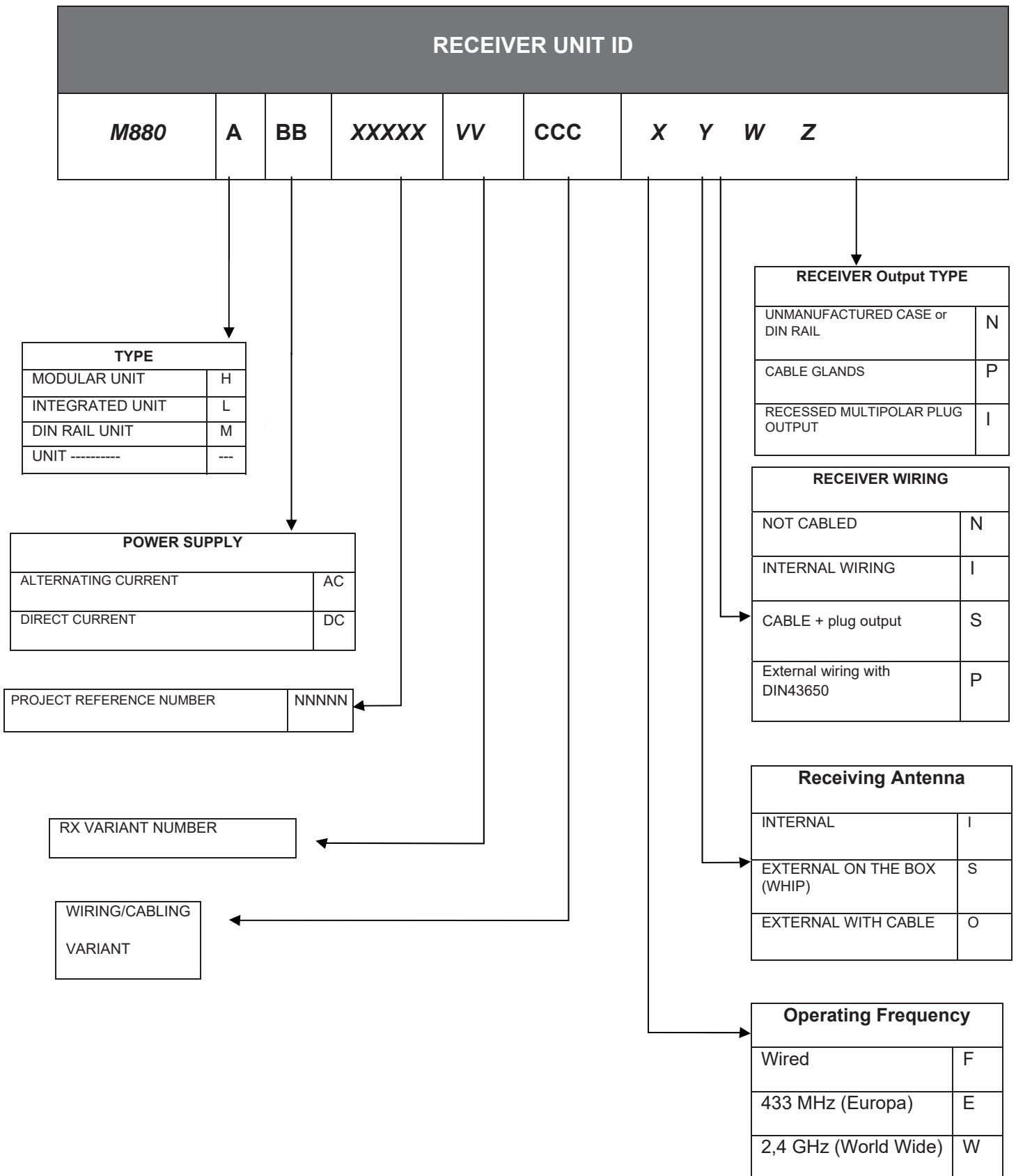

TRANSMITTER UNIT ID						
<b>M880</b>	Type	Sub Type	Display	Project #	Variant TX	Operating Frequency

↑
THOR2
ZEUS2
KRON
ARES2
WAVE2
G4L
G4S
MODIN

Operating frequency	
Wired	F
433 MHz (Europa)	E
2,4 GHz (World Wide)	W

M#	Up to 9 single axis joysticks
B#	Up to 4 dual axis joysticks
X#	Up to 7 single and dual axis joysticks
NJ	No joysticks
L## (WAVE2 only)	Pushbutton transmitter with 10 or 12 buttons + Start/Stop
S# (WAVE2 only)	Pushbutton transmitter with 6 or 8 buttons + Start/Stop
E## (ARES2 only)	Transmitter with selectors, buttons and potentiometers (from 2 to 10) with STOP button
C## (ARES2 only)	Transmitter with selectors, buttons and potentiometers (from 2 to 10) NO_STOP button

nn	TX Variant number
----	-------------------

nnnnn	Project reference number
-------	--------------------------

Yes	D
Not mounted	N
None	

### 1.1. Documentation

All IMET radio remote controls are accompanied by the following documents:

- User's Manual (**the annexes are an integral part of the manual**)
- Warranty Certificate

If any document is missing, please contact IMET and provide the unit's serial number.

## 2. CONVENTIONS USED IN THIS MANUAL

---



**Warning:** This symbol indicates instructions to be strictly followed for the radio remote control to work properly.



**Danger:** This symbol indicates important information aiming to prevent dangerous situations when using the radio remote control.



**Note:** This symbol indicates useful suggestions for the proper use of the radio remote control.

## 3. CAUTION

---



**READ THE INSTRUCTIONS CAREFULLY BEFORE INSTALLING THE RADIO REMOTE CONTROL! FAILURE TO APPLY ANY OF THE PROCEDURES DESCRIBED IN THIS MANUAL MAY LEAD TO INJURIES TO PERSONS OR DAMAGES TO PROPERTY.**

**NO PART OF THE RADIO REMOTE CONTROL SHOULD BE USED AS A SPARE PART FOR OTHER RADIO REMOTE CONTROLS.**

Follow the local laws on safety and workplace accident prevention. All the regulations on using radio remote controls for industrial machinery **MUST BE OBSERVED AT ALL TIMES.**

**IMET assumes no responsibility for the unlawful use of the radio remote control.**

### 3.1. Risk analysis

It is necessary to evaluate the risks in order to establish the safety and health safeguard requisites concerning the machine using the radio remote control. A risk analysis must be carried out when deciding whether an application can be radio controlled or not. It should be carried out by qualified personnel (**the installer**), who assumes all the relevant responsibilities.



**IMET assumes no responsibility for failure to carry out a proper risk analysis.**

An eventual loss of communication between the transmitter and the receiver, caused by disturbances or electromagnetic interferences, shall automatically block the radio command (clause 9.2.7.3 EN 60204-32), thus implying a restart of the machine. This casual shutdown should be foreseen in the risk analysis.







### 3.2. Applications

The most common radio remote control applications regard lifting or carrying equipment, such as tower cranes, bridge cranes, truck cranes and concrete pumps. Other applications are possible provided the following conditions are observed:

Do not use the radio remote control in environmental or electrical conditions other than those specified in Chapter 12. Do not use the radio remote control in environments that are required to be explosion-proof.



## 4. SIGNIFICANCE OF THE SYMBOLS IN LABELS

	<p><b>Class II equipment</b> To identify equipment meeting the safety requirements specified for Class II equipment according to IEC 60536</p>
	<p><b>Dangerous voltage</b> To indicate hazards arising from dangerous voltages.</p>
	<p><b>Direct current</b> To indicate on the rating plate that the equipment is suitable for direct current; to identify relevant terminals</p>
	<p><b>Alternating current</b> To indicate on the rating plate that the equipment is suitable for alternating current; to identify relevant terminals</p>
	<p><b>Don't use high-pressure water</b> To indicate not to clean using high-pressure water jets</p>
	<p><b>In house use</b> To indicate Indoor use only</p>

## 5. FCC-Regulatory Information (2,4 GHz radio module)

This equipment has been tested and found to comply with the limits for a digital device, pursuant to Part 15 of the FCC Rules. These limits are designed to provide reasonable protection against harmful interference in a residential installation. This equipment generates, uses and can radiate radio frequency energy and, if not installed and used in accordance with the instructions, may cause harmful interference to radio communications. However, there is no guarantee that interference will not occur in a particular installation. If this equipment does cause harmful interference to radio or television reception, which can be determined by turning the equipment off and on, the user is encouraged to try to correct the interference by one or more of the following measures:

- Reorient or relocate the receiving antenna.
- Increase the separation between the equipment and receiver.
- Connect the equipment into an outlet on a circuit different from that to which the receiver is connected.
- Consult the dealer or an experienced radio/TV technician for help.

**This device complies with Part 15 of the FCC Rules and with RSS-210 of Industry Canada.**

**Operation is subject to the following two conditions:**

- 1) this device may not cause harmful interference, and**
- 2) this device must accept any interference received, including interference that may cause undesired operation**



### **WARNING:**

**Changes or modifications made to this equipment not expressly approved by IMET may void the FCC authorization to operate this equipment.**

### **RF EXPOSURE NOTICE:**

The radiated output power of this device is below the FCC radio frequency exposure limits.

Nevertheless, the transmitters shall be used in such a manner that the potential for human contact during normal operation is minimized.

Based on evaluation of either the Specific Absorption Rate (SAR) according to the standard FCC KDB 447498 D01, the Industry Canada RSS-102 and EN 50566, EN 62209-2, using the transmitter with its carrying belt guarantees the compliance with RF exposure boundaries.



In order to avoid the possibility of exceeding the FCC radio frequency exposure limits, human proximity to the receivers with integrated antenna, or from its external antenna, shall not be less than 20 cm (8 inches) during normal operation.



## **6. PREVENTIVE MAINTENANCE**

---

**Before performing any maintenance operation, turn off the power to both, the receiving unit and the machine, and remove the battery from the transmitter.**

- Do not expose to heat sources
- Avoid prolonged exposure to direct sunlight
- Do not wash the device with water under pressure or dip it in water
- Avoid contact with oil or solvents
- If the device has been opened for any reason, make sure all the seals and gaskets are in place when closing
- When cleaning it, do not use alcohol or solvents, as they might damage the components and the housing.

### **6.1. Routine maintenance to be carried out by the operator**

Periodically clean the outside of the receiving and transmitting units. Dirt deposits could hinder the functioning of buttons, toggle switches and manipulators.

Apply special care to the STOP button, by keeping it clean and making sure it works effortlessly.

Remove any traces of rust from the battery contacts.

Check the casing and the components for cracks or apparent damages.

All rubber parts, buttons, seals and gaskets should show no sign of tearing.

Damaged components should be immediately replaced to prevent humidity or dirt from penetrating and jeopardizing the safe operation of the radio remote control.



### **6.2. Maintenance and internal checks**

After every year of use, we recommend carrying out a general inspection of the radio remote control (to be performed by qualified personnel).

Open the housings of the transmitting and receiving units and make sure:

- that the gaskets are in good shape
- that the cable clamps are efficient
- that the connection terminal screws and the connector couplings are tight
- that the electronic boards are securely fastened
- that the fastening screws of all components are tight

Although IP65 units are hermetically sealed, dust and humidity may accumulate over time when working in particular conditions. Carefully remove any foreign matter.

When closing the transmitting unit, apply special care to the casing's sealing, in order to prevent the infiltration of humidity.

Power on the device, being careful not to touch any live parts in the receiving unit, and perform the following tests:

- Check the functioning of all the controls.
- Verify that the STOP circuit intervenes correctly. By pressing the STOP button during operation, the relay contacts A and B of the E-STOP circuit must open.
- Any broken parts must be replaced with original spare parts, in order to keep the characteristics of the radio remote control unchanged. See the list of parts that can be replaced in Chapter 13.



## 7. INSTALLING THE RADIO REMOTE CONTROL

We recommend following the instructions below, in order to set up a properly operating radio remote control system.

The radio remote control should be installed by qualified personnel only.



**Install the receiving unit or its antenna (in case of versions with an external antenna) in the line of sight of the transmitting unit, with no electromagnetic shielding. To improve the operating range when the antenna is integrated, do not install the unit on metal surfaces, if possible.**

**Do not bypass the machine's safety systems; follow the manufacturer's instructions.**

Do not install the receiving unit too high above the ground (10÷20 metres). At these heights the unit may receive local radio signals that could disturb transceiving operations.

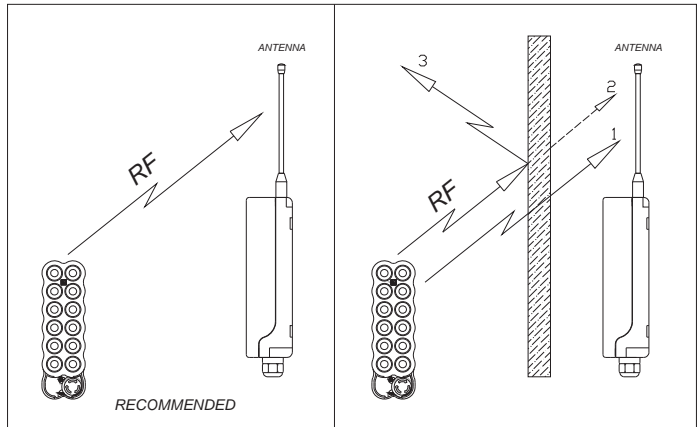

- 1 Non-attenuating obstacle
- 2 Partially attenuating obstacle
- 3 Shielding obstacle



**To prevent water infiltrations, install the receiving unit vertically, with the cable clamps and any other connections at the bottom, as shown in the figure.**

In case of strong mechanical vibrations, place a rubber shock-absorber between the machine and the receiver (dampers).

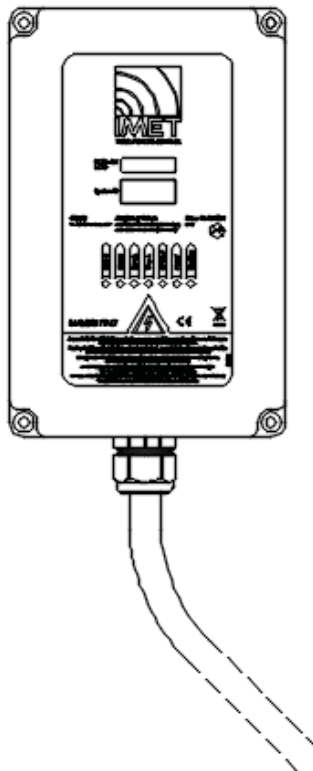

### 7.1. Receiving unit dimensions and drilling diagram

M880 LAC and M880 LDC versions

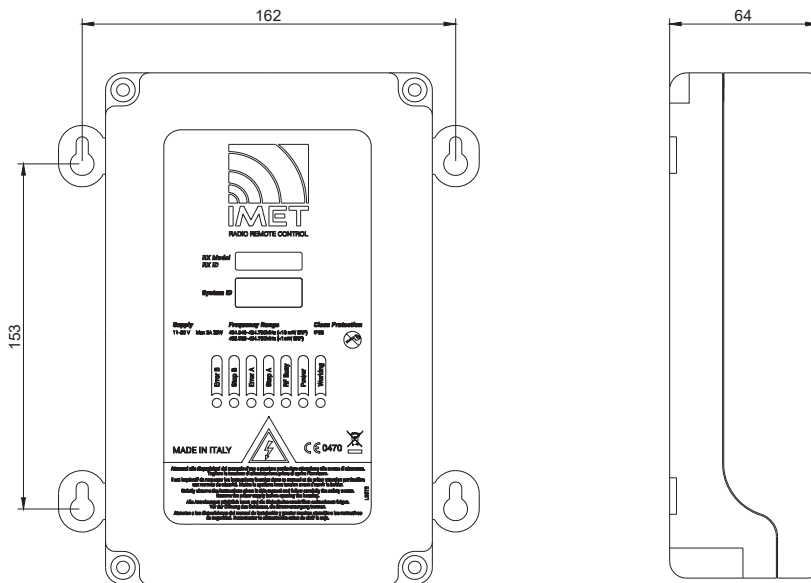

M880 HAC and M880 HDC versions

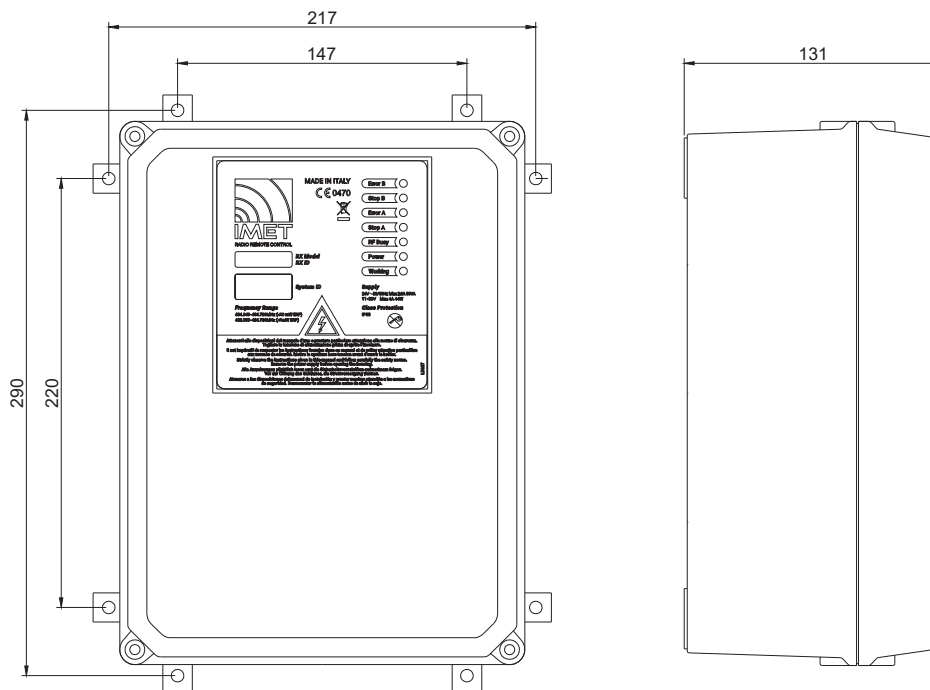

M880 MAC version

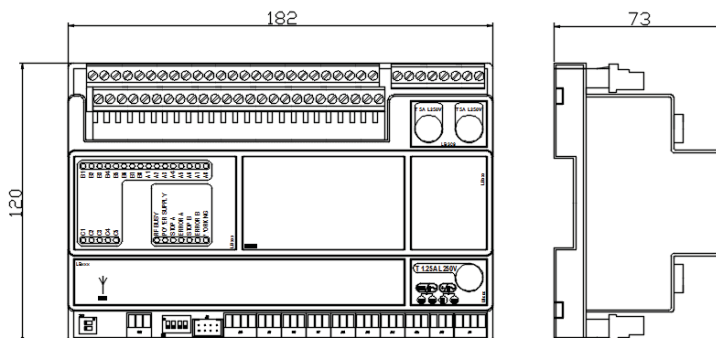



## 7.2. Connecting the receiver

Do not perform any operation until the equipment is powered off.

The power supply for the radio remote control should be located downstream from the machine's main switch.



**Connecting it directly to the mains distribution network is prohibited. The mains disconnecting switch must be equipped with a device to prevent unauthorized closing (padlock). It must be easily accessible and be attached outside of the equipment. The distance between contacts must be of at least 3 mm.**

The connection between the receiving unit and the machine should always be REMOVABLE. If the connection is made directly on the terminal board inside the machine, a multipolar connector should be used, so that the receiver can be disconnected and the original wired controls restored at any time.

Conductors and cables shall be selected so as to be suitable for the existing operating conditions (for example, voltage, current, protection against electric shock, grouping of cables), as well as external influences (for example, ambient temperature, presence of water or corrosive substances, mechanical stresses-including stresses during installation- and fire hazards). When cables are installed on hoisting machines used in the open air (outside buildings or other protective structures), they shall be suitable for outdoor use (for example, UV-resistant, adequate temperature range), or be appropriately protected.

The wire connections between the receiving unit and the machine should respect the Standard EN60204 and must be stranded. The wires must have a cross-section of at least 0.75 mm<sup>2</sup> and less than 13 mm<sup>2</sup> and be self-extinguishing. If the equipment is used with ambient temperature of 70°C the maximum conductor operating temperature must be greater than 75°C.

Use ferrules for conductor ends, if possible, and make sure that the terminals are fastened tightly.

Consult the transmitting unit control diagram (Annex T) and the receiving unit wiring diagram (Annex R) to identify the equivalent actuators in both units.



In the HDC version, the receiver is also intended to be electrically powered at a voltage of 24 VAC 50/60 Hz. Connect it to an external source where the dedicated 24 VAC output is separated from dangerous voltage parts by double or reinforced insulation.

In all receiver versions, the loads connected to the relay board must have a protection against over currents and overloads.

In the HDC version, the receiver is intended to be electrically powered in the voltage range 11 to 30 Vdc. Connect it to an external source where the dedicated 11-30 Vdc output is protected against overvoltage and short circuit. The 11-30 Vdc dedicated output external source must be connected to the main terminal earth protection or separated from the primary circuit by means of a metal screen connected to the main terminal of the earth protection.



When the receiver type HDC is provided with a metallic connector (mounted on the enclosure), the device shall be placed in a "service access area" not accessible to the operator, but only by the service staff **(EN 60950-1 4.5.4 Touch temperature limits of metals at 70°C)**

**Be sure to note the supply voltage when connecting the receiving unit.**

In versions HAC and LAC, the fuse current must be adjusted to the supply voltage.



**After installing, test the radio remote control and the machine to make sure they work as expected. In addition, it is very important to make sure that the STOP circuit works properly. Pressing the STOP button during normal operation should open the contacts of relays A and B in the E-STOP circuit.**

Lastly, fill-out the sheet showing the connection diagram between the receiving unit and the machine and write down the date of installation in the document DECLARATION OF CONFORMITY.

### 7.3. Installing the external antenna

A properly installed antenna is essential for a good operating range. Install the antenna outside at the highest and most visible point and far from metal structures. Use a tuned antenna only, and connect it to the receiver using a low loss coaxial cable (impedance 50Ω). Only use the antennas supplied by IMET; other types of antenna must be approved in conformity to the standard ETSI EN 300 220-2 / ETSI EN 300 328.

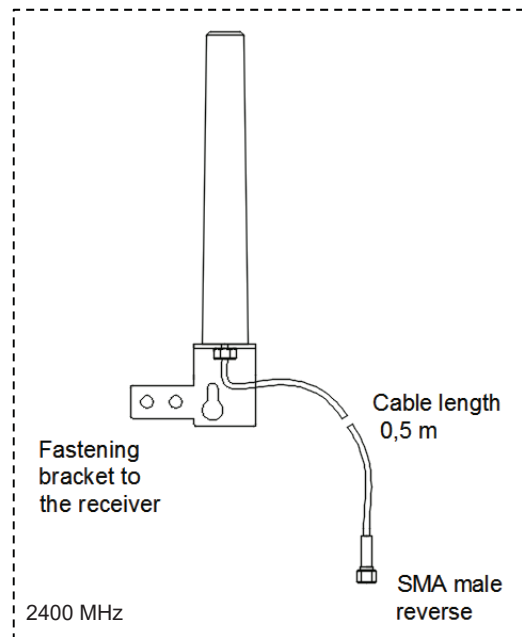
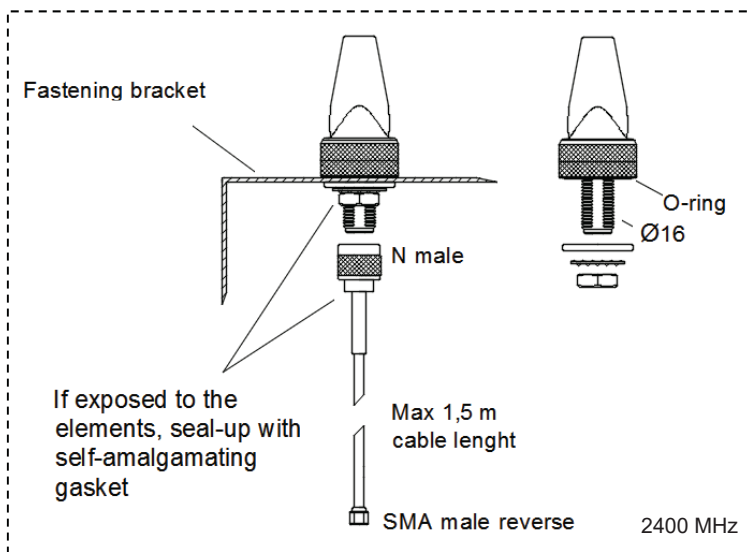
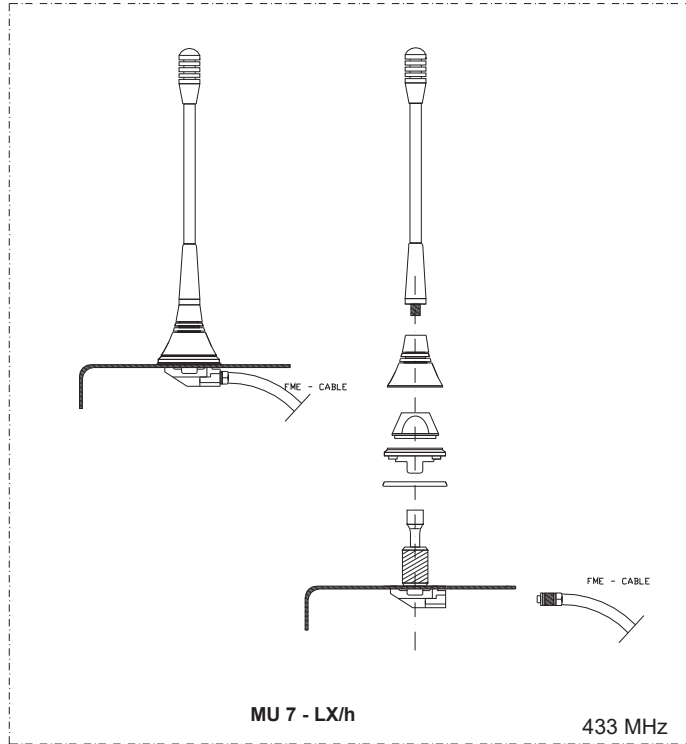

## 7.4. STOP (E-STOP)

Connect the contact of the E-STOP circuit so that it commands the coil of the machine's main line contactor and remember that the maximum allowable current is 5A with resistive load.



**Attention:** In order to maintain the safety category (PLe Category 4 according to ISO 13849-1), the STOP circuit relays must be connected in series (standard IMET pre - wiring configuration), or else in AC applications, individually connected in series to the phase line and neutral, ONLY for the mains power interruption (See Example 2). In series to the STOP relay contacts, there must always be a 5A fuse.

## 7.5. SAFETY ENABLE (S-ENABLE)

The **Safety Enable** is an additional safety function. It consists of a relay in the receiver that is monitored by the RX logic and that can be associated with the commands sent by the transmitter, which in case of problems, automatically stops the receiver, as shown by the LEDs status.

**Example 1** (in series with control commands): The Safety Enable introduces a redundancy, which activates the safety function in case the control command relays fail to open.

**Example 3** (operating the bypass valve): The Safety Enable can command the drain valve in a hydraulic machine, such that the machine is powered only when a control command is given.

### The Safety Enable must not be associated with stable selection commands

The risk analysis and safety class are based on standard ISO 13849-1. Take good notice of the maximum currents allowed on the relay contacts (see Chap. 12).

### **Example 1: Wiring of safety-ENABLE relay for generic applications (5A MAX load)**

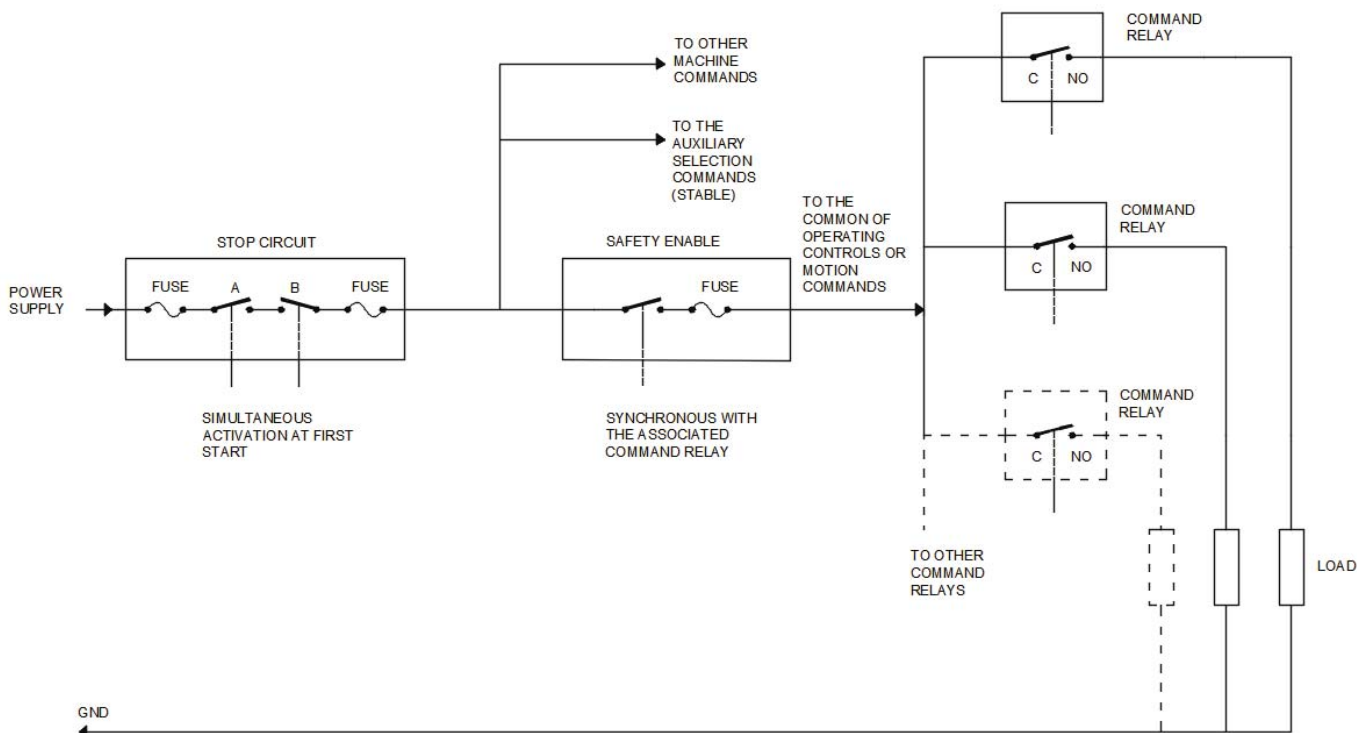

**Example 2: Wiring of STOP relays for special application**

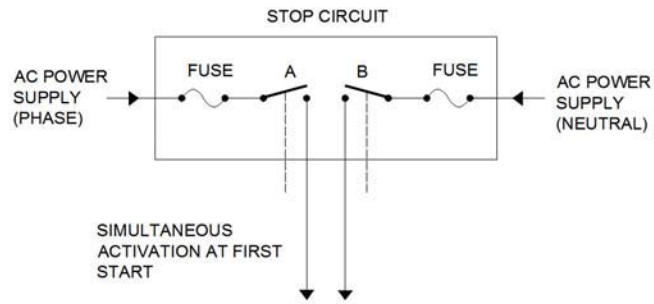

**Example 3: Wiring of the Safety-ENABLE relay for hydraulic DC applications**

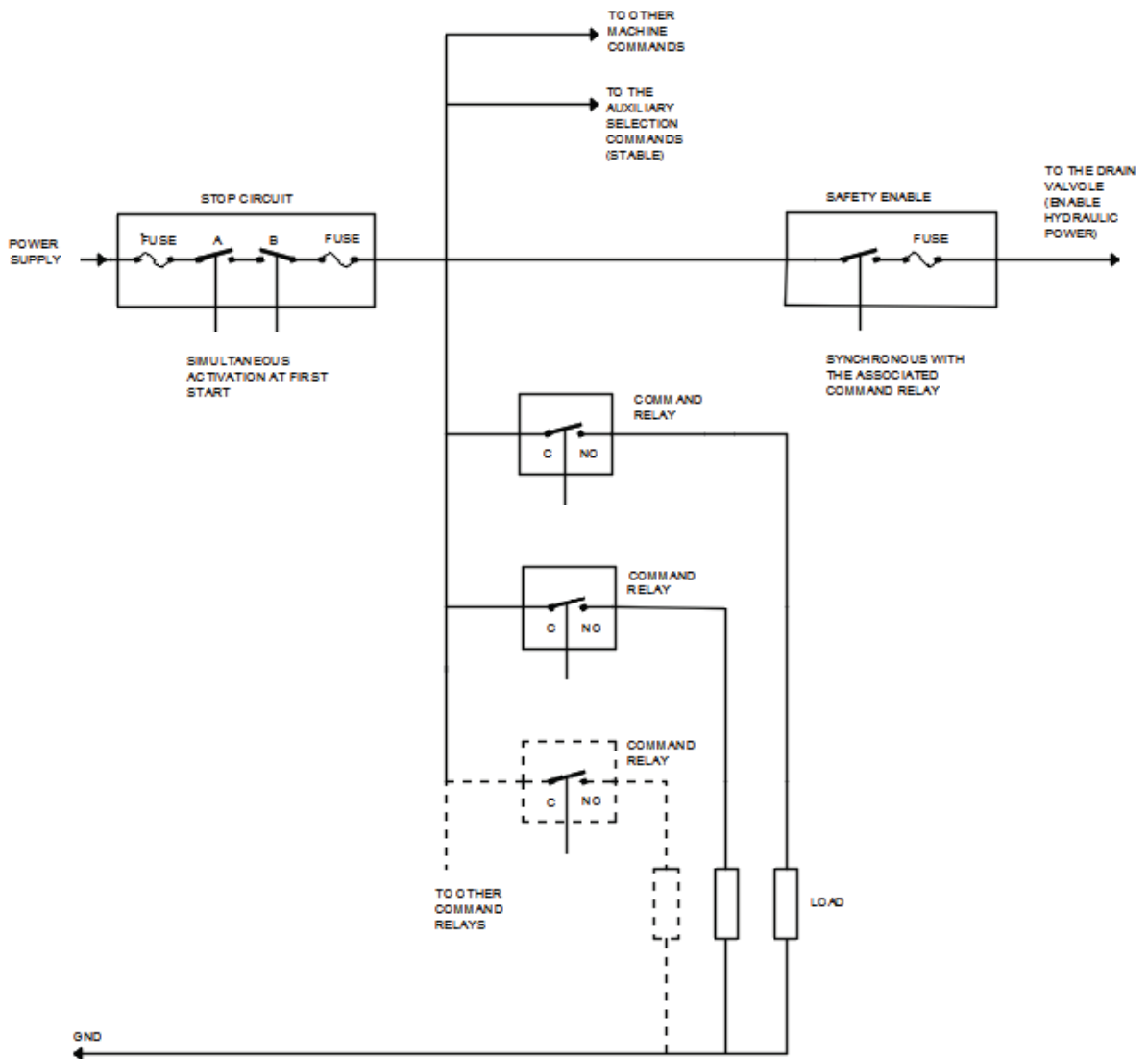



## 7.6. Basic functions board PCB201 (DC) / PCB231 (AC) (Service card)

The table below shows the basic functions available on the service board.

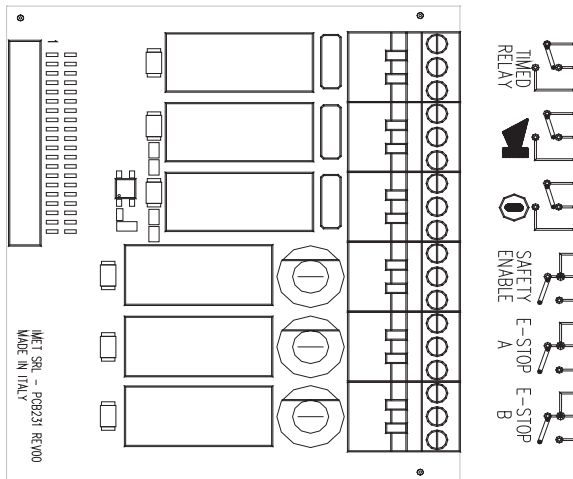

Relay	Function	Typical Uses	Remarks
TIMED-RELAY	The relay is activated for 5 seconds from the moment the radio remote control is switched off or has entered in passive emergency mode. The T-RELAY can be activated at switch-off or with a 2-second delay.	<ul style="list-style-type: none"> <li>Delayed STOP of combustion engine</li> <li>Engine deceleration</li> </ul>	
SAFETY-ENABLE	The relay is activated only by an unstable command from a toggle switch, button or joystick When <b>Connected in series</b> , the function introduces a redundancy that can be used to increase function safety	<ul style="list-style-type: none"> <li>Enables the drain valve</li> <li>Common enabling of control commands</li> </ul>	Relays constantly monitored by uP.
E-STOP	The two relays are activated when the radio remote control is switched on with the START button (STOP RELAY with PLe cat. 4 ISO13849-1) and stay active until a STOP command intervenes (pressing the STOP button or passive emergency)	<ul style="list-style-type: none"> <li>Powers the main contactor in the machine's control box</li> <li>Common power supply for control commands</li> <li>Machine power supply</li> </ul>	Relays constantly monitored by uP
HORN	Horn control relay	Warns of potentially hazardous situations	it can be associated to the first START
START	START control relay	Powers the machine's control box and enables the machine Start function	

The SAFETY-ENABLE on the 9-relay board can be activated only by the ones present on the board itself.

## 7.7. Connection diagrams of H receivers

The receiving unit version H is provided with 7 slots, where control relay cards, analog output cards and a data feedback card can be inserted. The basic functions/controls in the table above are located in the SERVICE board.

The basic receiver configuration includes the power supply board with the relay card on SLOT B, the logic card on SLOT RX and the SERVICE card on the SERVICE slot.

According to the project specifications, you may have:

- RELAY cards (8 + SAFETY, 10 and 13)
- MOSFET cards (8 + SAFETY, 10 or 12)
- Analog output card
- Data feedback card (PCB262) to be inserted in slot A

The configuration HAC does not allow for the use of 13-relay cards, due to the presence of the AC transformer.

## 7.8. HDC (PCB200) receiver with analog output cards and data feedback card

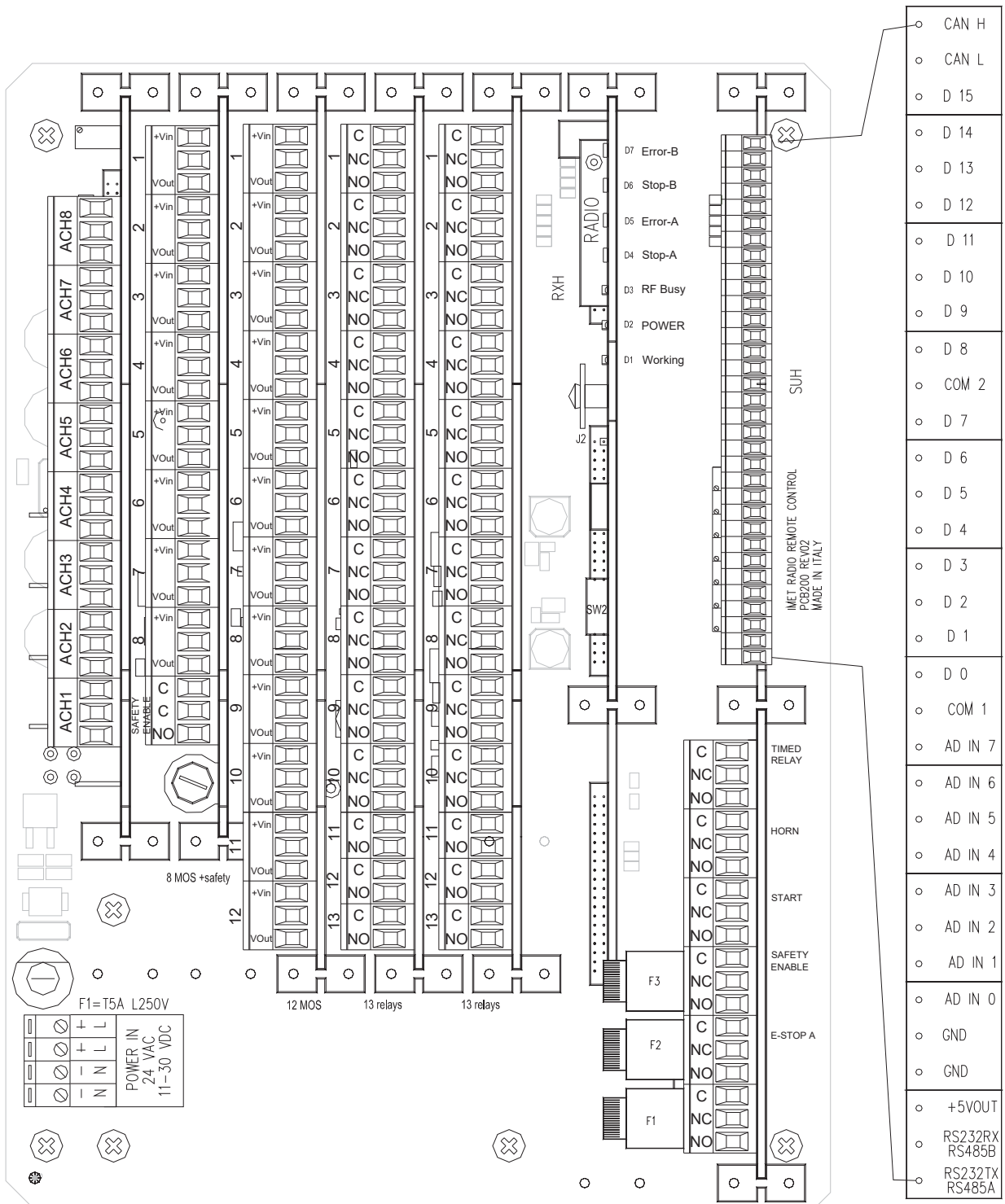

### 7.9. HAC (PCB230) receiver with analog output cards and data feedback cards

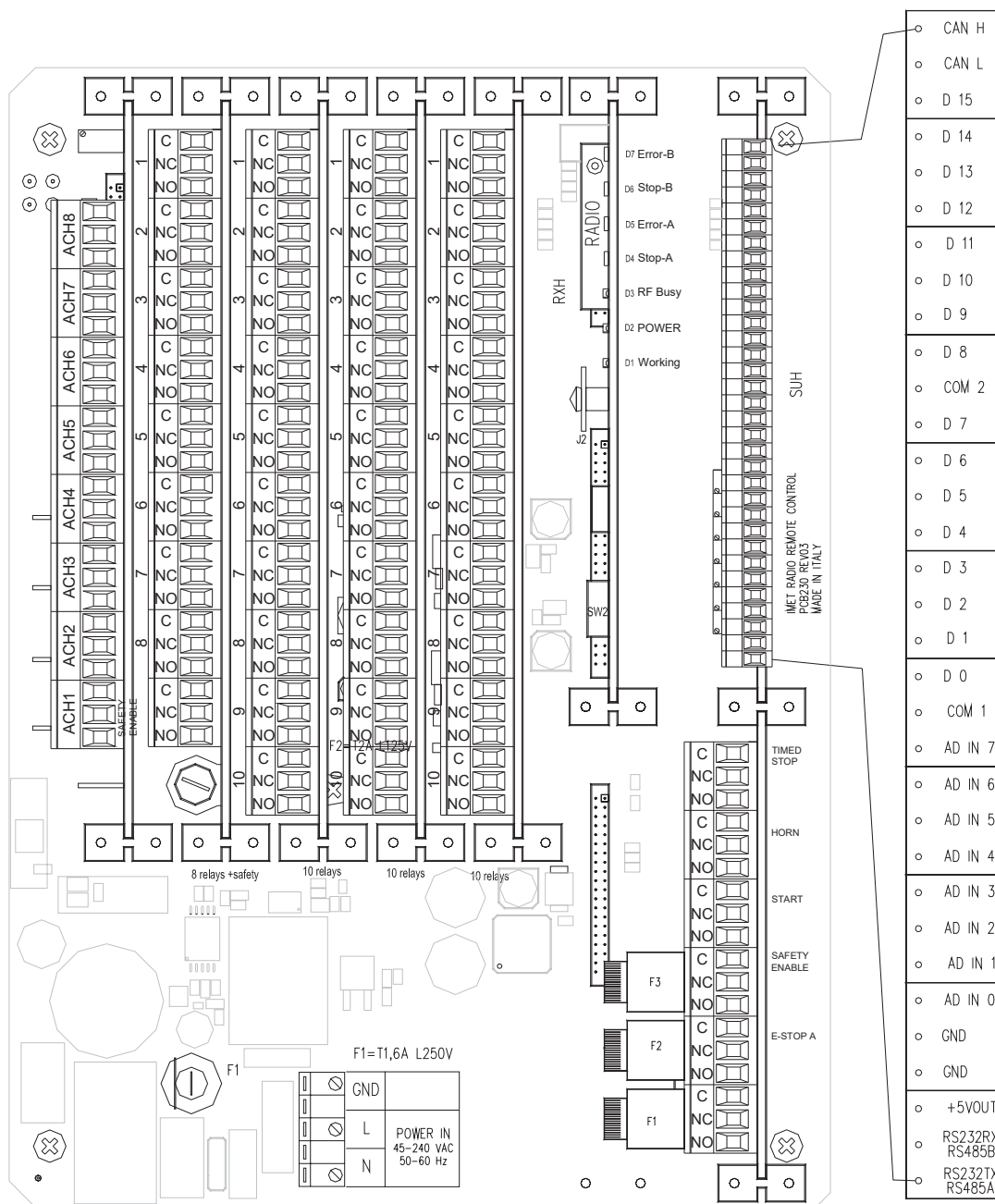

### 7.10. Power supply connections of HDC and HAC receivers

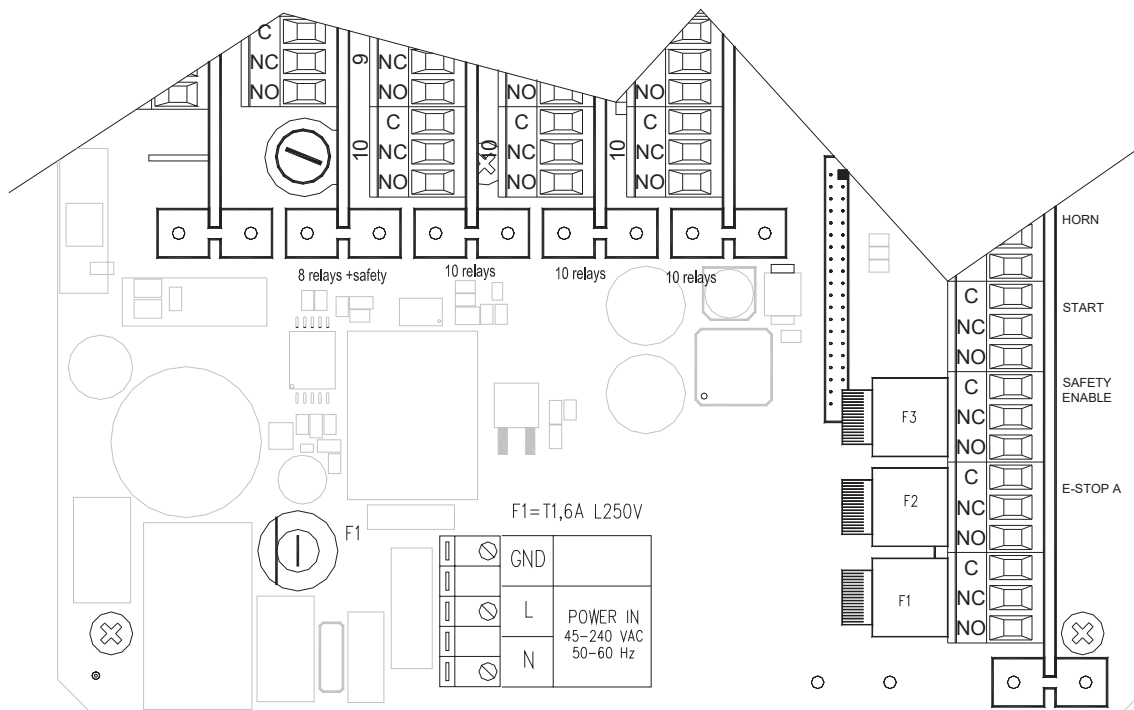
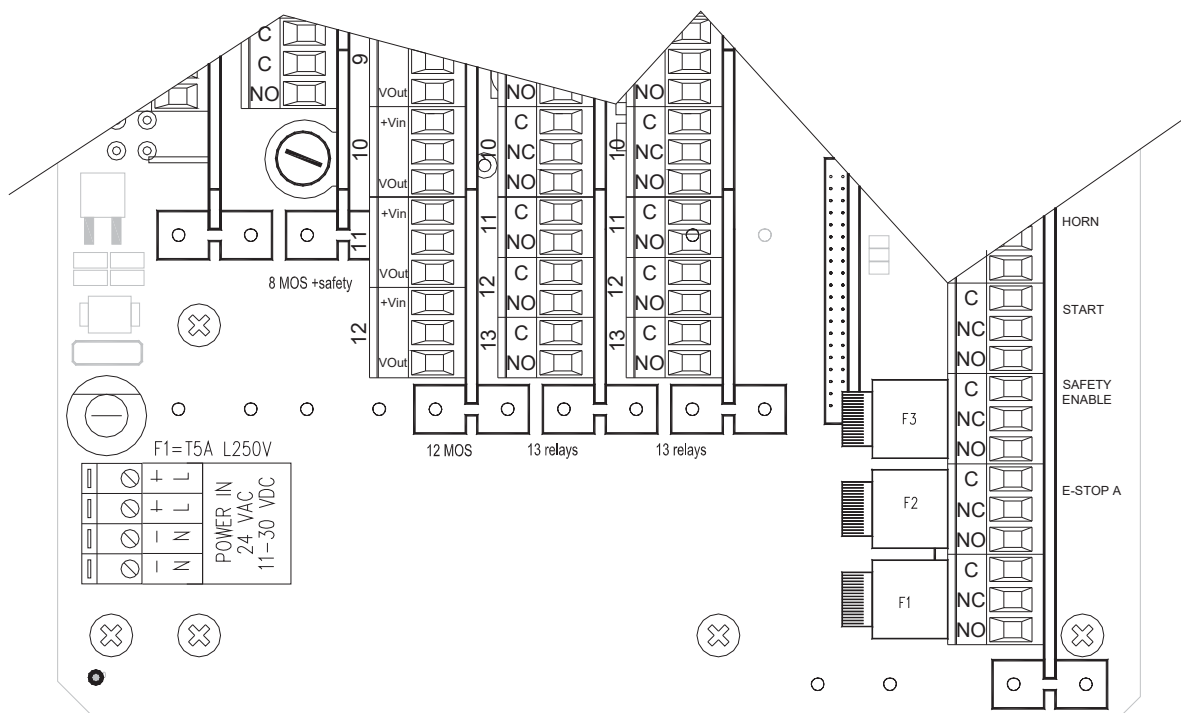

## 7.11. Analog command board (PCB261)

This board can control 8 proportional outputs (PWM: voltage and current) by inserting the appropriate IMET command modules.

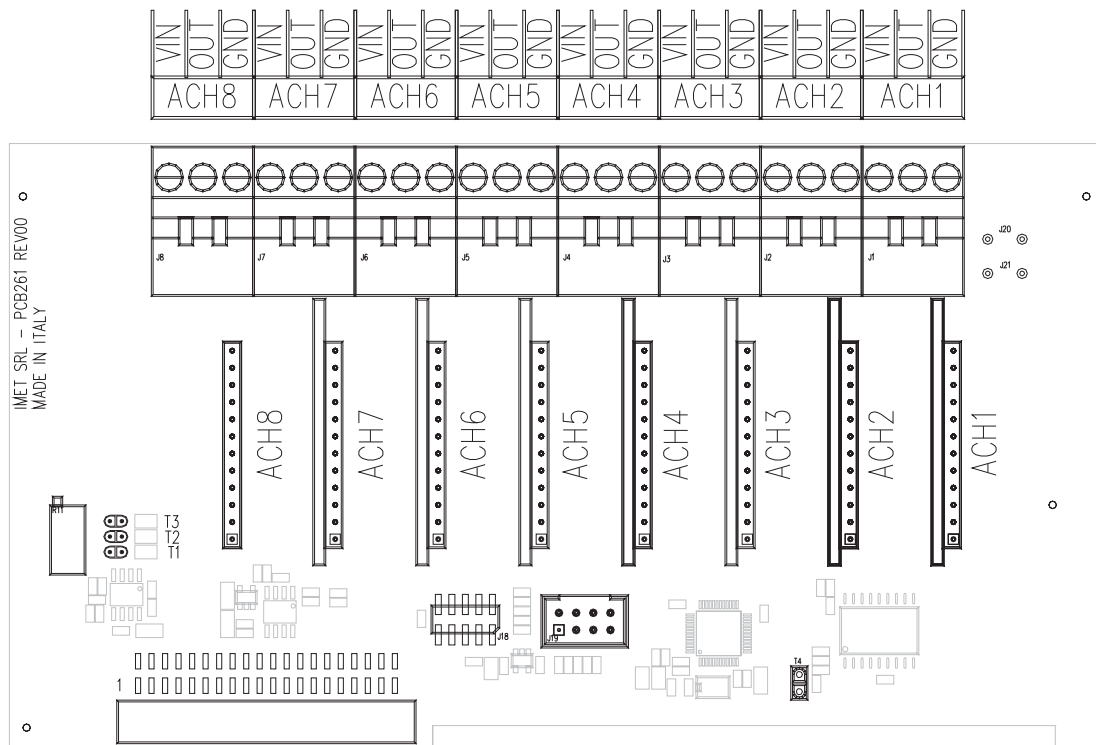

### Command modules

M550C2: 0-20mA/4-20mA current-operated control

M550C1: PWM current-operated control

M550V: voltage-operated control

The frequency value of the PWM oscillator can be set by adjusting the R11 trimmer and shorting solder-jumpers T1, T2 or T3. (J22 test point is used for frequency measurement).

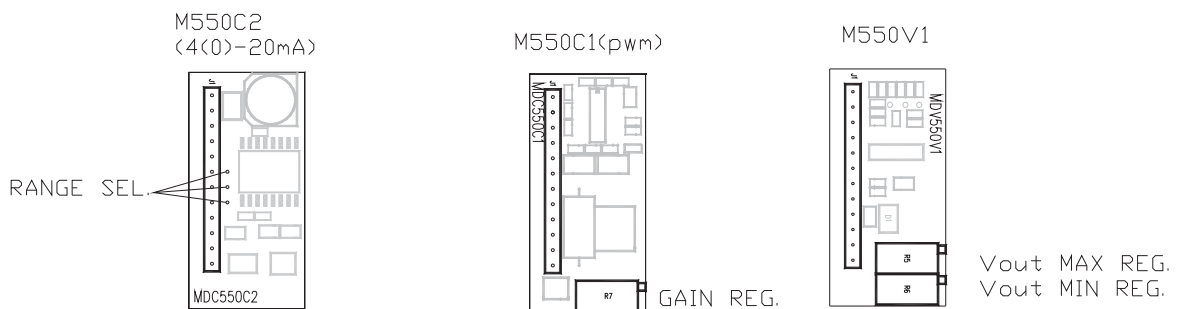

## 7.12. Logic board (PCB260)

The logic board receives and decodes the commands coming from the transmitting unit. The board is preset for an (optional) serial connection with the transmitting unit for data reception via cable.

<b>Error B</b>	Generally OFF: when flashing, it reports uB error codes
<b>Stop B</b>	RED while uB is STOPPED; GREEN while uB is WORKING
<b>Error A</b>	Generally OFF: when flashing, it reports uA error codes
<b>Stop A</b>	RED: while uA is STOPPED; GREEN while uA is WORKING
<b>RF Busy</b>	WHITE: ON while the radio LINK is present
<b>POWER</b>	GREEN: Power supply lamp
<b>Working</b>	BLUE: ON if 12V PWR SUPPLY is active
<b>DIP-SWITCH SW2</b>	See § 6.8 (Settable output configurations by means of dip-switches).

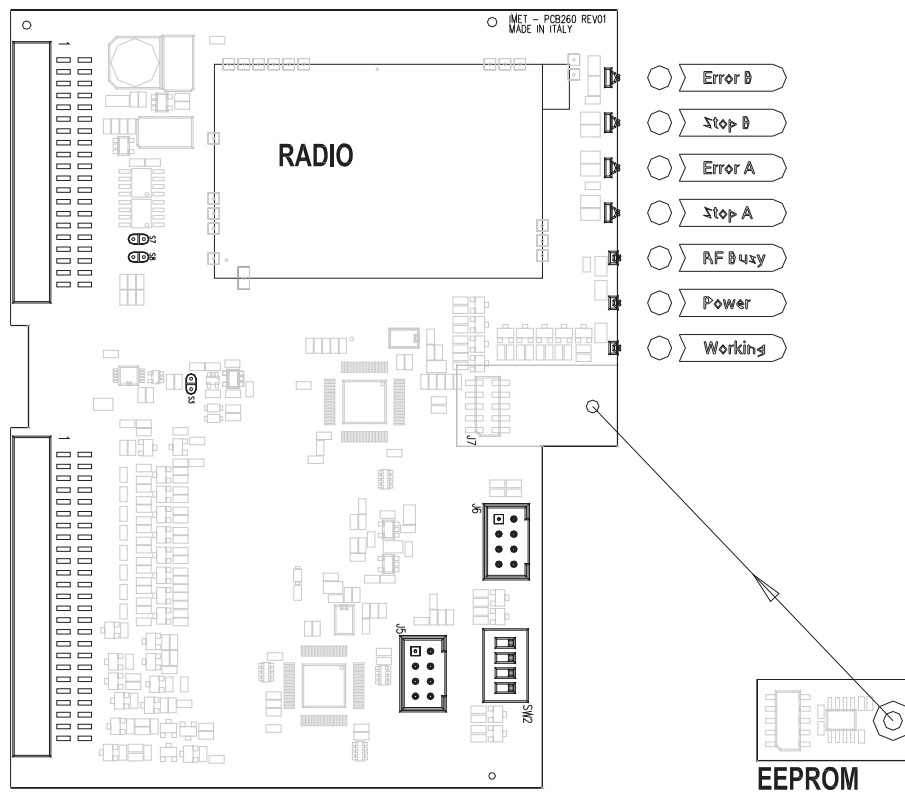

### 7.13. Data feedback card (PCB262)

The data feedback card is used when it is necessary to collect data from the application and send it via radio to the display of the transmitting unit. Data collection can be done by means of 16 digital inputs (OPTOCOUPLED) and 8 analog inputs (voltage or current configurable). The card features also a CAN BUS connection and a serial line (standard RS232 or RS485).

Note:

- The choice between RS232 or RS485 is done during the card's mounting phase.
- The voltage/current analog reading is selected by the solder jumpers T0..T7 and T8..T15.
- 500 ohm Zin of current analog input (the source must be able to supply at least 10V to the inlet of the card). The trimmers R1..R8 are used for a fine adjustment.
- The DIP SWITCH SW1 is set according to the customer's instructions.

Terminal	Description
CAN-H,CAN-L	Outputs for CAN BUS connection
D0- D15	Digital inputs (optocoupled) (24V, Zin > 3.3k)
COM1/2	Common reference (ground) for digital inputs (COM1 related to D8-D15; COM2 related to D0-D7)
AD IN0-AD IN7	Analog inputs (12 bit) (VIN_max 10V)
+10V	Auxiliary power supply (Imax = 100 mA)
GND	Ground reference for analog signals
VCC	Power supply
CURRENT GAIN AD IN0-AD IN7	Set-up trimmer for AD0-AD7 analog inputs
RS232/485	Serial communication port

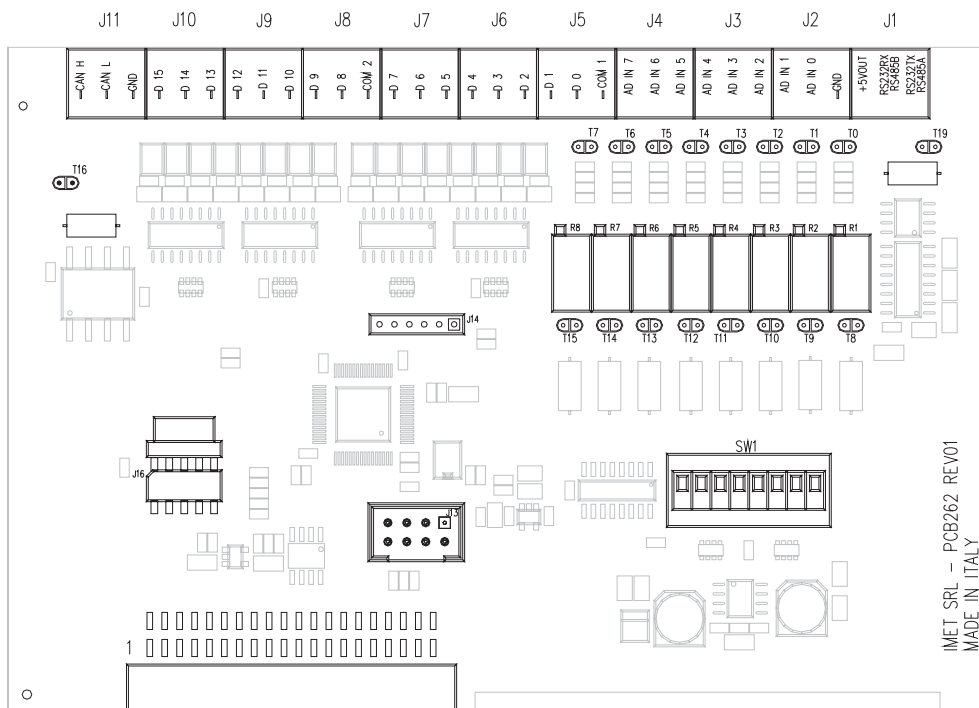



### 7.14. Relay cards

On the H receiver, different cards can be mounted on the free slots, depending on the user's requirements.

#### RELS: 8 relay DC model with N. 1 SAFETY-ENABLE relay (PCB203)

8-relay card (N.C. / N.O. contacts) with N. 1 SAFETY ENABLE relay (8A) on board.

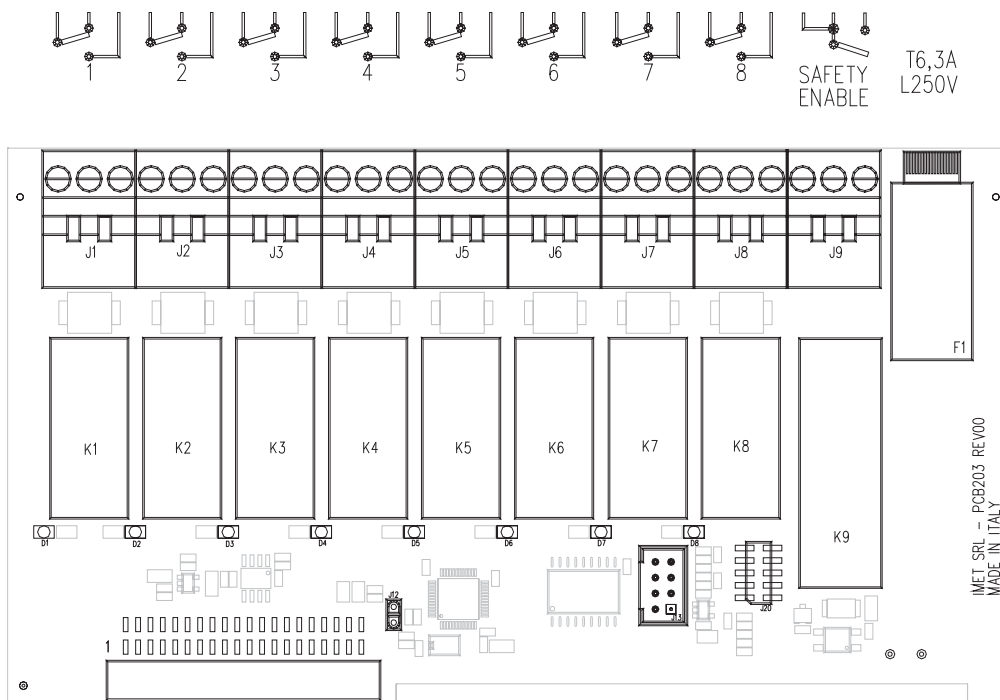

#### REL10: 10 relay DC model (PCB202)

10 relay card (N.C. and N.O. contacts) (If a safety command is needed for these outputs, use the SERVICE's SAFETY ENABLE relay).

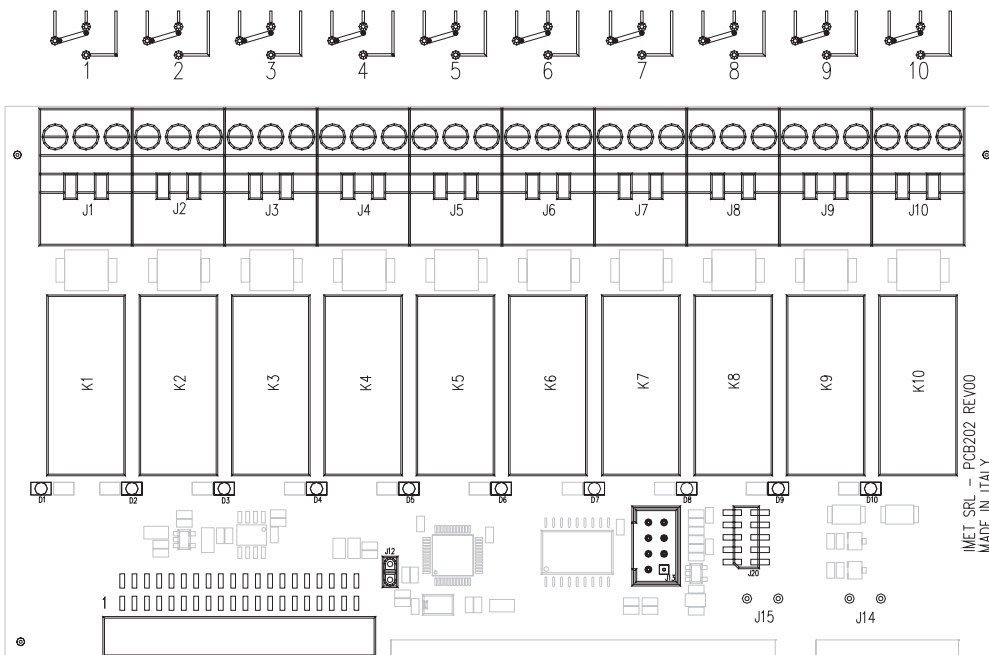

**REL13: 13 relay DC model (PCB204)**

13 relay card:

- 10 relays (NC/NO contacts).
- 3 NO relays. (If a safety command is needed for these outputs, use the SERVICE's SAFETY ENABLE relay).

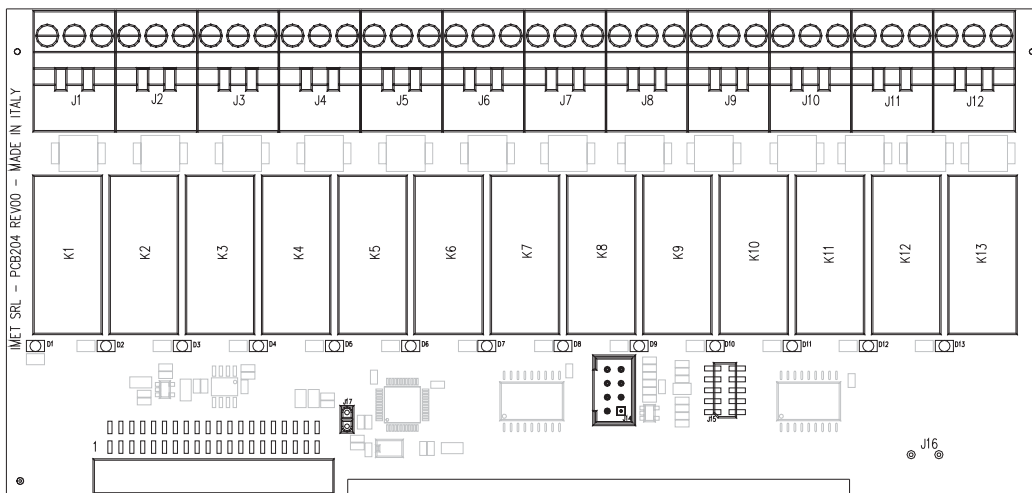
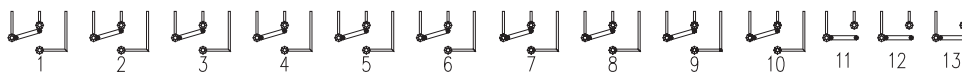

**REL10AC: 10 relay AC model (PCB232)**

10 relay card:

- 10 relay board (NC/NO contacts). (Use the SAFETY ENABLE relay on the service board if control is required)

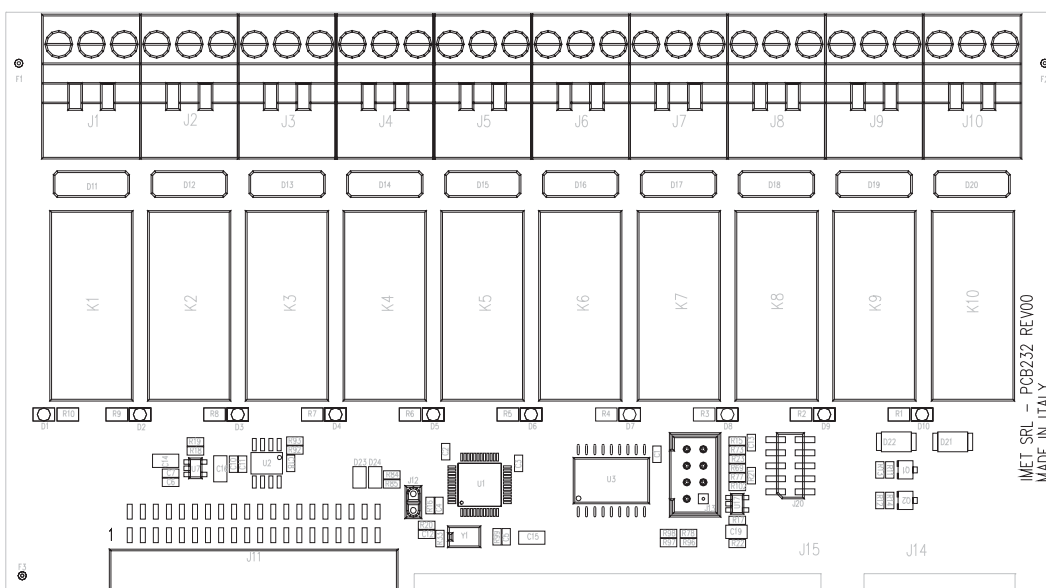
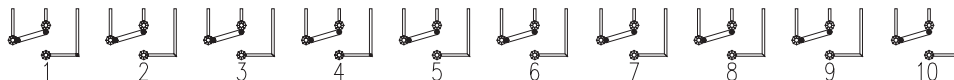

### 7.15. Boards with solid state relays (MOSFET)

#### MOS8S: 8 MOSFET with N. 1 SAFETY-ENABLE relay on board (PCB205)

8-MOSFET board with SAFETY.ENABLE relay on board:

- 8 MOSFET (NO output)
- 1 on board SAFETY ENABLE relay (NO contact).

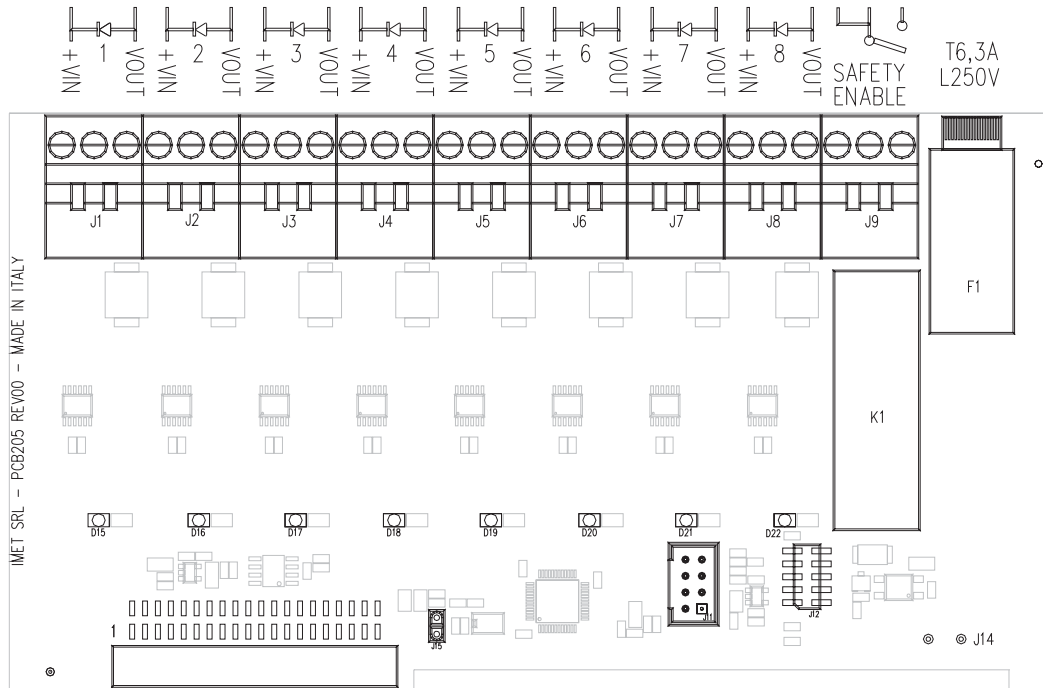

#### MOS10S: 10 MOSFET board (PCB206)

- 10 MOSFET (N.O.) board

Note: If safety control is needed, use the SERVICE's SAFETY ENABLE relay

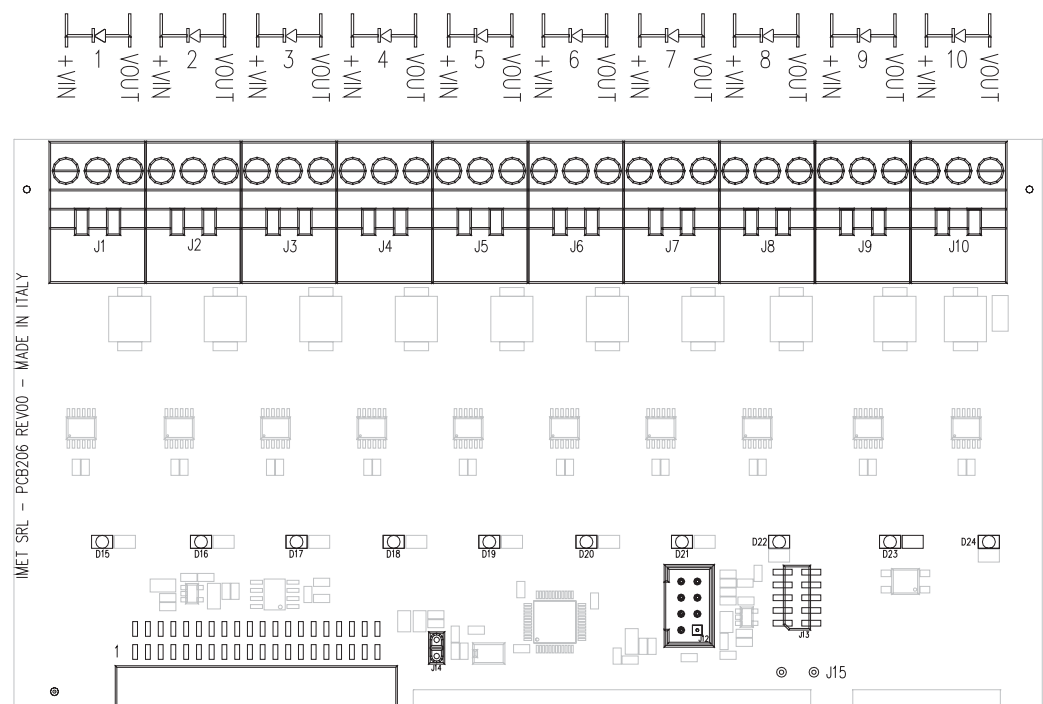

## MOS12S: 12 Mosfet board (PCB207)

- 12-MOSFET board without N. 1 SAFETY-ENABLE relay (8A) on board.

Note: If safety control is needed, use the SERVICE's SAFETY ENABLE relay.

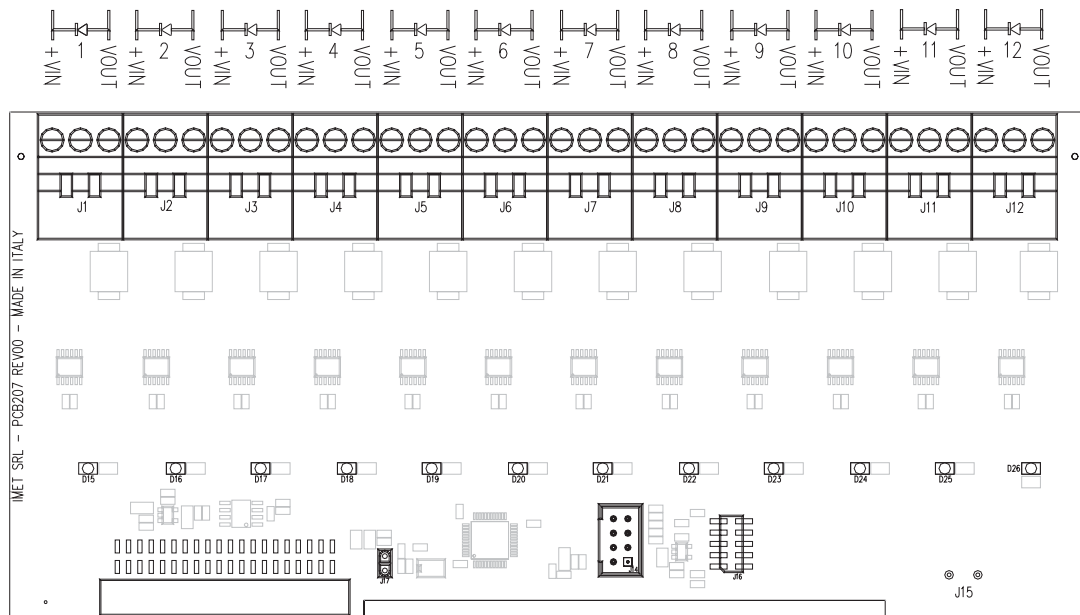

### 7.16. Potentiometer card (M880DT2)

Used for controlling tower cranes. The potentiometer card lets you set the operating speeds independently.

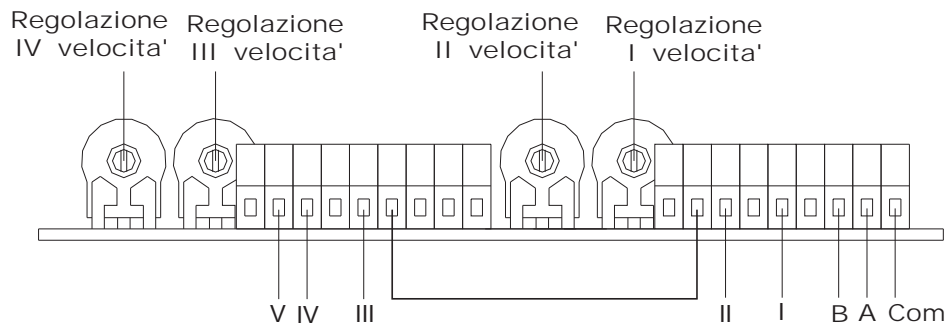

### 7.17. Connection diagrams for L receivers

The L receiving units are equipped with a slot that can be used for:

- 1 card with relay outputs for AC or DC versions or, alternatively
- 1 card with MOSFET outputs + 1 card with analog outputs for DC versions only

The safety enable relay and the basic functions are located directly on the motherboard, as shown in the table in Chap. 7.6.

### 7.18. M880 LDC Version (PCB100)

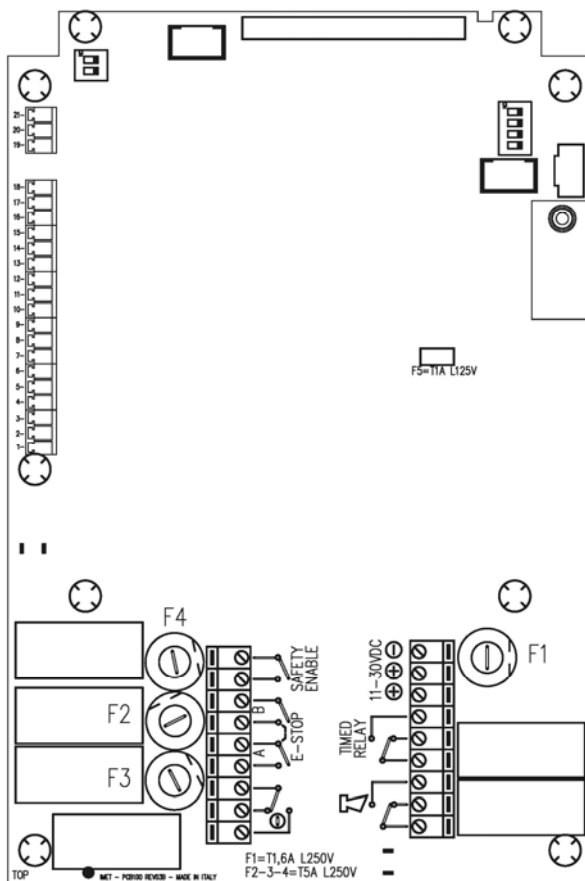

Options on demand	SYMBOL	DESCRIPTION
	<b>11- 30VDC IN</b>	Power supply input
	<b>GND</b>	Ground connection
	<b>F1</b>	Power Supply fuse T4A L250V
	<b>F5</b>	Protection fuse 5VDC T1A L250V
	<b>SAFETY-ENABLE</b>	Safety-Enable relay
	<b>E-STOP A</b>	E-STOP A relay
	<b>E-STOP B</b>	E-STOP B relay
	<b>F2 , F3 , F4</b>	Protection fuses E-STOP and SAFETY_ENABLE T5A L250V
	<b>START</b>	Output relay N.O.
	<b>HORN</b>	Output relay N.O. / N.C. HORN command
	<b>TIMED – RELAY</b>	N.O. / N.C. relay
	<b>CAN-H</b>	CAN-H Line
	<b>CAN-L</b>	CAN-L Line
	<b>D0-D7</b>	Digital Inputs 0-20V
	<b>AIN0-AIN3</b>	Analog Inputs 0-10VDC
<b>SERIAL CONNECTION CABLE</b>	<b>J2-2</b>	RS485 DATA +
	<b>J2-3</b>	RS485 DATA –
	<b>J2-4 +12</b>	Auxiliary power supply 12VDC I <sub>max</sub> = 500mA
	<b>J2-1 GND</b>	Ground connection

7.19. M880 LAC Version (PCB130)

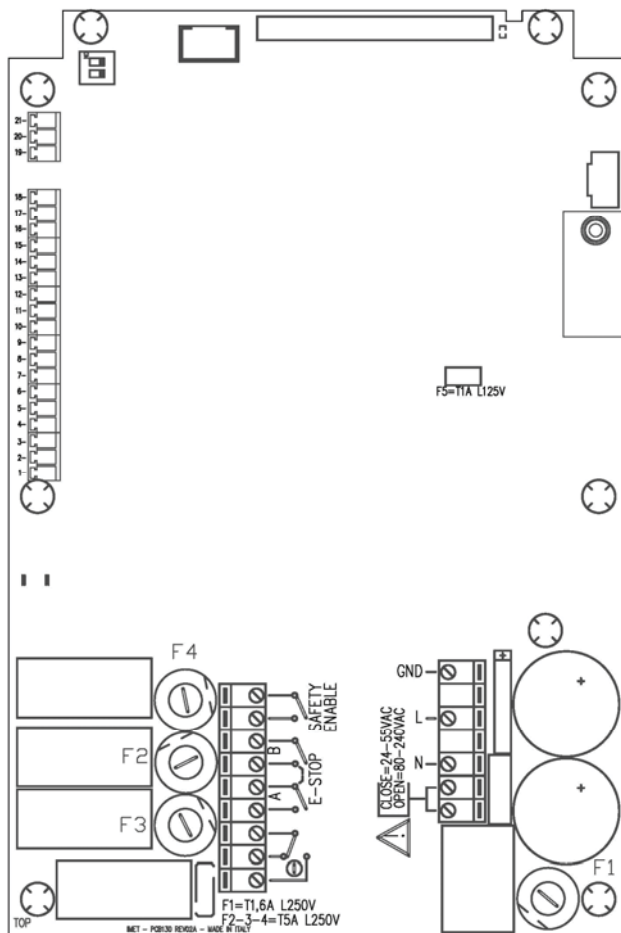

Options on request	SIMBOL	DESCRIPTION
	<b>24..240 VAC</b>	Power supply input
	<b>GND</b>	Ground connection
	<b>F1</b>	Power Supply fuse T4A L250V
	<b>F5</b>	Protection fuse 5VDC T1A L250V
	<b>SAFETY-ENABLE</b>	Safety-Enable relay
	<b>E-STOP A</b>	E-STOP A relay
	<b>E-STOP B</b>	E-STOP B relay
	<b>F2 , F3 , F4</b>	Protection fuses E-STOP and SAFETY_ENABLE T5A L250V
	<b>START</b>	Output relay N.O.
	<b>HORN</b>	Output relay N.O. / N.C. HORN command
	<b>TIMED - RELAY</b>	N.O. / N.C. relay
	<b>CAN-H</b>	CAN-H Line
	<b>CAN-L</b>	CAN-L Line
	<b>D0-D7</b>	Digital Inputs 0-20V
	<b>AIN0-AIN3</b>	Analog Inputs 0-10VDC
<b>SERIAL CONNECTION CABLE</b>	<b>J2-2</b>	RS485 DATA +
	<b>J2-3</b>	RS485 DATA -
	<b>J2-4 +12</b>	Auxiliary power supply 12VDC I <sub>max</sub> = 500mA
	<b>J2-1 GND</b>	Ground connection

## 7.20. Relay board for M880 LAC and M880 LDC receivers

N. 20 relays board for LAC receiver (PCB131)

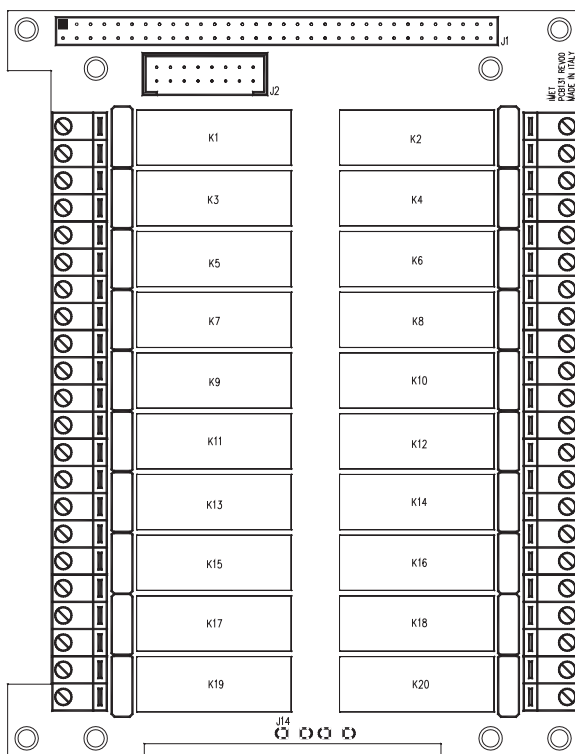

The relays C3 and C4 can be configured as HORN and blinker by closing the jumpers.

N.16 relays board for LDC receiver (PCB101)

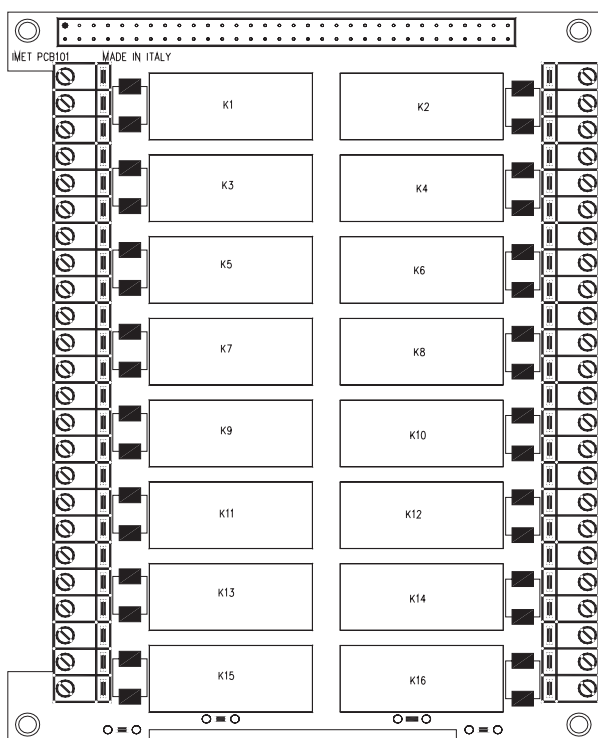

N.14 relays board for LDC receiver

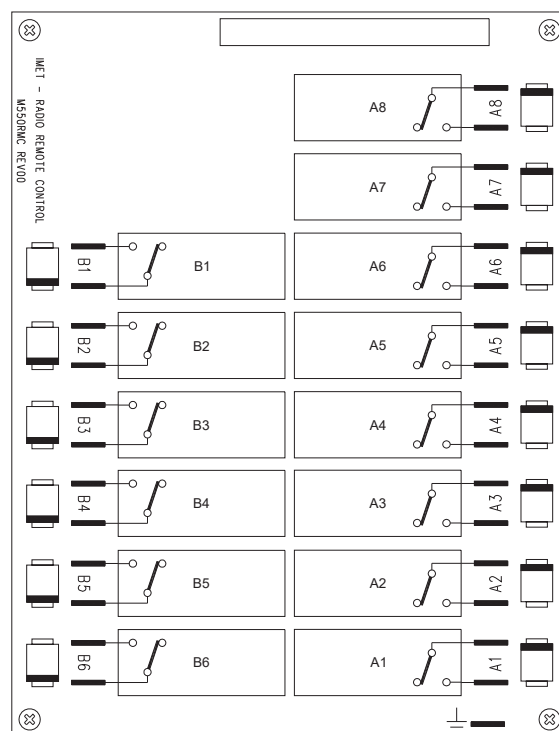



**7.21. Other command boards for M880 LDC**

**N. 12 (ON/OFF MOSFET + n. 4 ANALOG OUT (PCB104)**

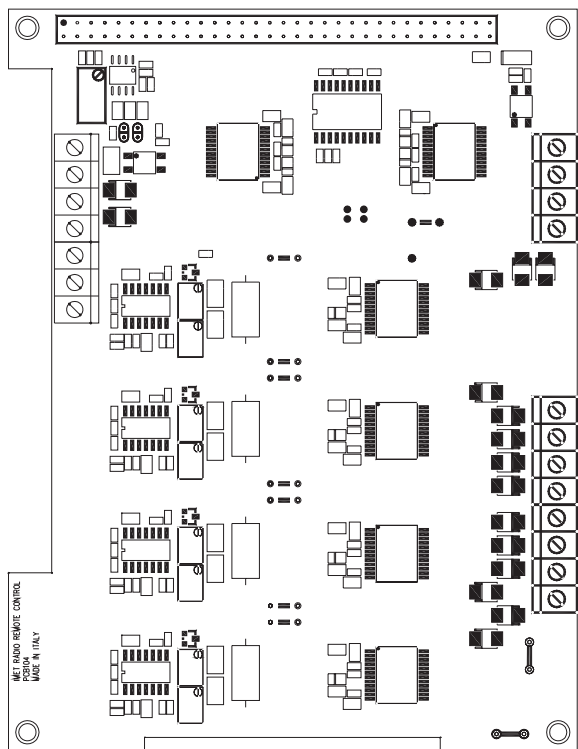

**N.20 (ON/OFF MOSFET (PCB102)**

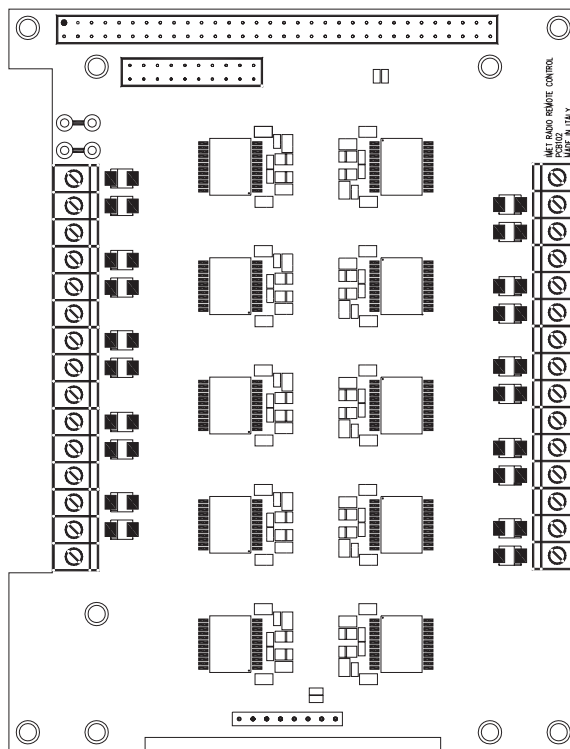

**N. 8 ANALOG OUT (PCB103)**

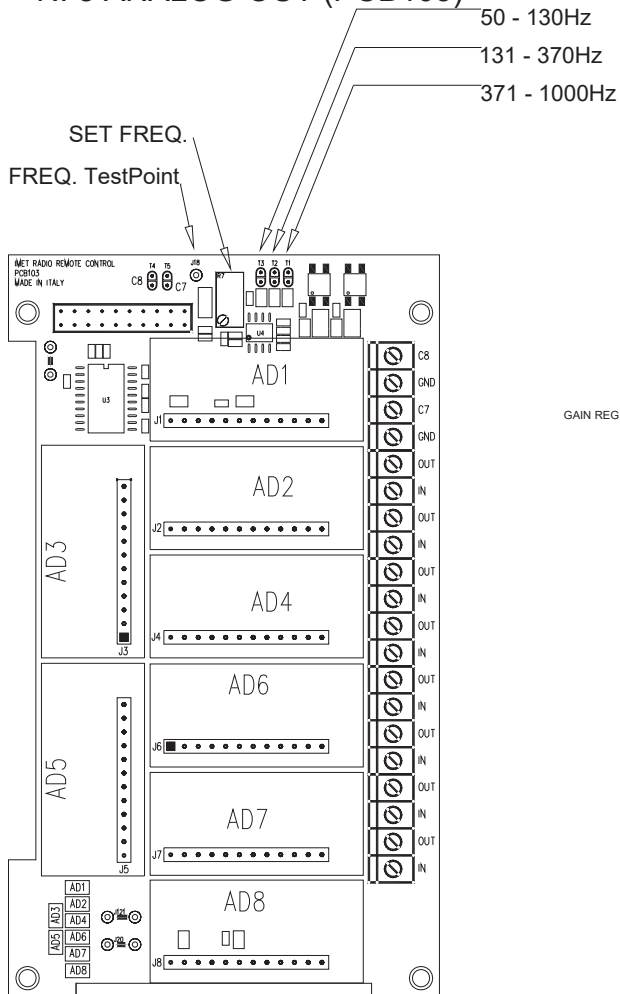

**N. 2 H MOTOR DRIVER (PCB110)**

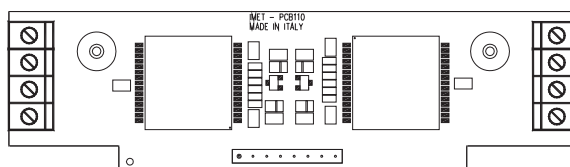

**Moduli di comando**

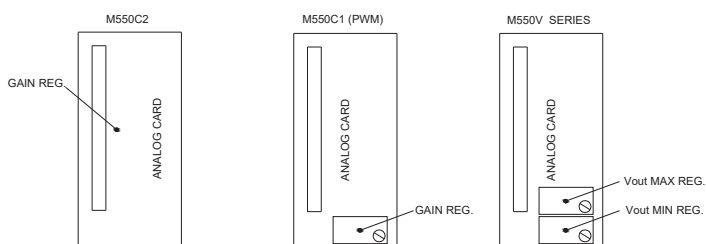

M550C2: comando in corrente 0-20mA / 4-20mA  
 M550C1: comando in corrente PWM  
 M550V: comando in tensione

## 7.22. Connection diagrams for M receivers

The M receiving are DIN rail mountable units, equipped with:

- relay outputs for AC or DC versions
- analog inputs, analog outputs, digital inputs, CAN bus, RS232/RS485 line
- safety relays

## 7.23. M880 MAC Version (PCB300)

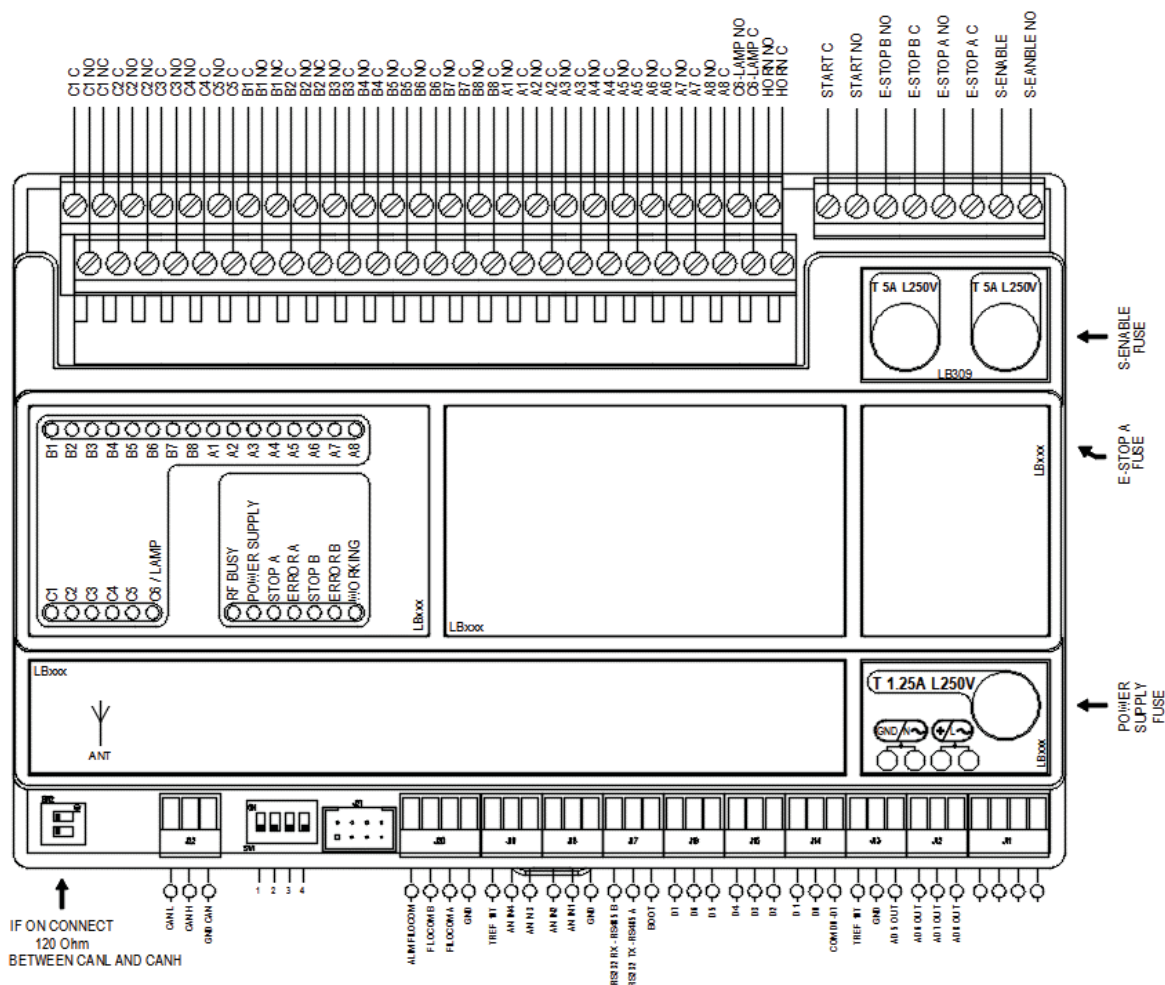

Options on demand	SYMBOL	DESCRIPTION
	<b>12V-30VDC /24VAC</b>	Power supply input
	<b>GND</b>	Ground connection
	<b>F3</b>	Power Supply fuse T1.25A L250V
	<b>S-ENABLE</b>	Safety-Enable relay (protected with F2 fuse)
	<b>E-STOP A</b>	E-STOP A relay (protected with F1 fuse)
	<b>E-STOP B</b>	E-STOP B relay
	<b>F1 , F2</b>	Protection fuses E-STOP and SAFETY_ENABLE T5A L250V
	<b>START, HORN</b>	Service relays (N.O.) (CLAXSON settable on C6)
	<b>D0-D7</b>	Digital Inputs 0-20V
	<b>AIN1-AIN4</b>	Analog/digital Inputs 0-10V
	<b>AD5-AD8</b>	Analog Output 0-10V/-10 to 0 to 10V/0-20, 4-20mA/ 25%-50%-75%Vcc/ 0-Vdc (Vcc-3)
	<b>A1-A8, B1-B8, C1-C6</b>	Relay contacts (18 NO + 4 NC/NO)
	<b>LAMP</b>	Service Relay
	<b>VREF 10V</b>	Voltage reference
<b>SERIAL CONNECT ION CABLE</b>	<b>RS232/RS485</b>	RS485 DATA+ / RS485 DATA- or RS232 LINE
	<b>CAN-H, CAN-L</b>	CAN bus lines
	<b>FILO_COM_X</b>	Data wire interface between transmitter and receiver
	<b>ALIM_FILOCOM</b>	Auxiliary power supply 12VDC I <sub>max</sub> = 500mA for the transmitter

## 7.24. Serial data transmission

The radio remote control is preset for optional serial data transmission and acquisition. The connection between the radio remote control and the user's equipment is done with a 15m long serial cable (for standard RS232) and a Baud Rate of (9600 sps). For lengths over 15m, move on to standard RS485.

## 7.25. User serial (RS232/RS485)

This connection is used in customized applications to receive data from an external device and to send data to the transmitter's display.

The following messages can be sent:

- **Messages stored in the application's memory**

The messages must be sent to the RS232 connection in data packets following the serial protocol shown below. The application must send to the data feedback card the single characters that make up the message to be shown on the display of the transmitting unit.

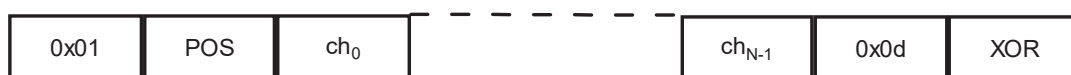

└─── Ordine di invio ──▶

BYTE	Description
0x01	A variable indicating the start of the message.
POS	Position of the message's starting point on the display.
Ch <sub>0</sub> ...Ch <sub>N-1</sub>	Generic i <sup>th</sup> character sent to the display (text of message).
0x0d	A variable indicating the end of the message. The variable is a hexadecimal value, different from any ASCII character that can be shown on the display.
XOR	XOR of all the preceding bytes starting from 0x01 (parity check).

- **Messages stored in the data feedback card's memory**

In this case the application sends an N code to the data feedback card regarding the message (N) to be sent and shown on the display of the transmitting unit.

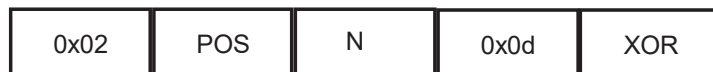

└─── Ordine di invio ──▶

BYTE	Description
0x02	A variable indicating the start of the message.
POS	Position of the message's starting point on the display
N	Number of the message stored in the card data feedback card.
0x0d	A variable indicating the end of the message. The variable is a hexadecimal value different from any ASCII character that can be shown on the display.
XOR	XOR of all the preceding bytes starting from 0x01 (parity check).

## 7.26. Serial connection cable

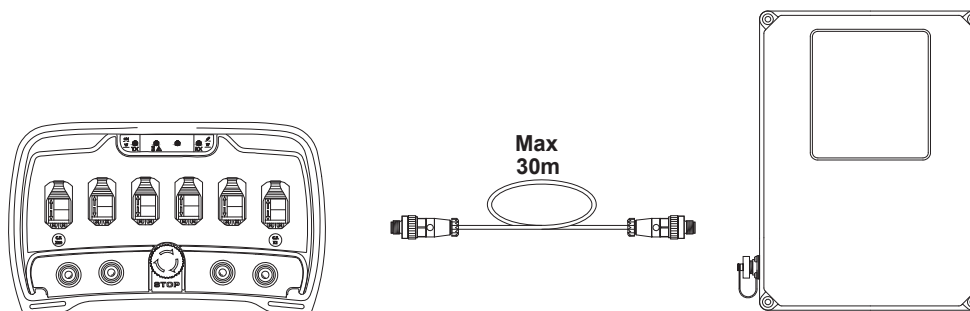

This option is used to exchange commands and data via cable between the transmitter and the receiver. The serial connection cable excludes the radio frequency transmission and the receiver provides the power for the transmitter. To restore radio operation, disconnect the cable from one of the two sides and turn-on the radio remote control by pushing the START button.

## 8. USING THE RADIO REMOTE CONTROL

Use of the radio remote control following the safety precautions below, to ensure safety at work.



### 8.1. Safety rules

The radio remote control should be used only by competent personnel with a thorough understanding of the remote control and of the controlled machine. All the persons using the radio remote control should be adequately instructed.

**Do not turn-on** the transmitting unit if the controlled machine is not completely visible. If the transmitting unit is used in a closed area or far from the receiving unit, the operator may not be fully aware of all the controlled machine movements. This can lead to hazardous situations.



Whenever work is suspended, even for short periods, turn off the control unit and remove the battery pack from the transmitter, to prevent unauthorized use. **The IMET battery has the same function as the access key.** If necessary, the installer has also the option of enabling the access code.

### 8.2. Powering and starting the radio remote control

#### Initial conditions

- Transmitting unit off.
- Load a charged battery in the transmitter (except for M8 DIN units).
- **Make sure the mushroom-head STOP button is not pressed and that no command is in the working position.**
- Power on the machine and the receiving unit.
- Wait 2 seconds for the receiver to carry out the safety check. If the check is successful, the red "Passive Emergency Stop A and B" LEDs and the green Power Supply LED will stay on.
- **Turn-on the transmitter with START and wait for the link between the transmitter and the receiver to set (GREEN and BLUE LEDs blinking on the TX, while the WHITE RF Busy LED is lit on the RX).**

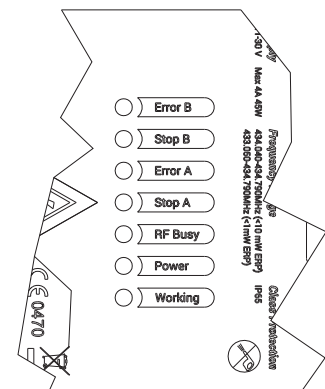

Whenever the access code option is enabled, the green LED activates continuously; procede as follows:

1. Move the joystick or the selector C.F.x1 for as many times as the first digit of the access code
  2. Confirm the digit by pressing START
  3. Repeat the sequence for the rest of the code digits
- **Press the Start button for one second: The GREEN light (TX) and the BLUE light (RX) turn on and remain steady, meaning the unit is working properly. On the receiver, the RED STOP A and STOP B LEDs will turn to GREEN, and the "Working" BLUE LED will turn on. The radio remote control is now ready to execute the desired commands.**

### 8.3. The STOP function

Press the red mushroom button. This will open the STOP circuit on the receiving unit and disable all the commands. To restore operations, reset the STOP button (ISO 13850) and press START.



#### 8.4. Turning off the remote control

There are three ways to turn the remote control off:

- Press the red mushroom button; after 10 seconds the remote control will turn off
- When present, turn the key lock switch counterclockwise.
- Remove the battery

The transmitter will turn off, the safety circuits will open and all active commands will be disabled. The transmitting unit also turns off when the battery runs down completely.

#### 8.5. Auto power-off (Time-out)

On request, the auto power-off time can be set to a maximum of 60 minutes, in one-minute steps.

The M880 DIN-mounted transmitting unit, turns-off automatically after 20 hours of continuous duty, in order to automatically look for malfunctions in the safety systems, in accordance with Standard ISO 13849-1.

Upon explicit request from customers (and under their own responsibility), the auto power-off function on DIN units can be excluded. In this case, the STOP circuit is downgraded to category 3 or PLd.



#### 8.6. Transmitter indicator LEDs

The transmitter is issued with 3 LEDs that provide the following information:

- Operating status
- Operating malfunctions
- Type of malfunction
- Battery exhausted



<i>Transmitting Unit</i>	<i>Indication</i>
<b><i>TX LED Status ( GREEN )</i></b>	
<i>Off</i>	<i>Transmitter off or damaged (see § 8)</i>
<i>On</i>	<i>Radio link established between receiver and transmitter</i>
<i>Blinking</i>	<i>Radio link established. Not running:(Stop)</i>
<b><i>Led Status (YELLOW)</i></b>	<i>Multi-functional indicator</i>
<i>Battery out of charge</i>	<i>Two close blinks followed by 20s pause</i>
<i>Joystick setup</i>	
○ Test phase	ON continuously
○ Setting of Minimum	Single blink followed by a pause
○ Setting of Maximum	Double blink followed by a pause
○ Setting of the Inverse	Blinks continuously
<i>Morse code</i>	<i>Error indication on transmitter</i>
<b><i>RX Led Status (BLUE)</i></b>	
<i>Off</i>	<i>Receiver is off or defective</i>
<i>Blinking</i>	<i>Radio link established</i>
<i>On</i>	<i>Receiver is operating</i>

The receiver is equipped with 7 LEDs that signal

- Operation status
- Malfunctions
- Diagnostic functions and type of faults
- Power supplies status
- Link status

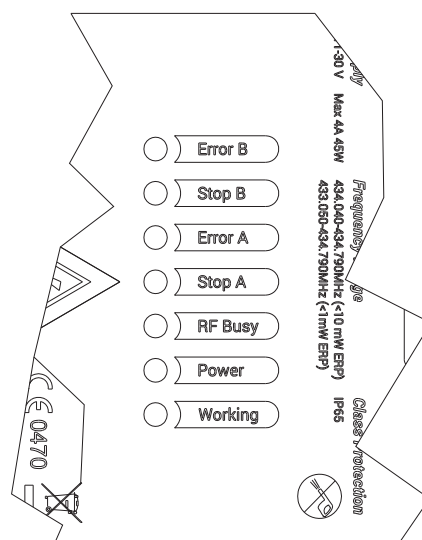

<b>Receiving Unit</b>	
<b>LED</b>	<b>Indication</b>
<i>Error B</i> <b>(Red/Green LED)</b>	Normally OFF during running mode. Red/Green error sequence while Channel B is in fault status
<i>Stop B</i> <b>(Red/Green LED)</b>	<i>Green while running.</i> <i>Red: system B channel is in STOP status.</i>
<i>Error A</i> <b>(Red/Green LED)</b>	Normally OFF during running mode. Red/Green error sequence while Channel A is in fault Status.
<i>Stop A</i> <b>(Red/Green LED)</b>	<i>Green while running. Red: system's channel A is in STOP status.</i>
<i>RF Busy</i> <b>(White LED)</b>	<i>ON if the link between remote control and receiver is established. Its intensity is proportional to the received signal's intensity. If cable connected, the RF Busy LED blinks at a fixed rate.</i>
<i>Power Supply</i> <b>(Green LED)</b>	<i>On if POWER is ON .</i>
<i>Working</i> <b>(Blue LED)</b>	<i>ON if radio link between receiver and remote control is established and the necessary power supply is present for the correct functioning.</i>

During the setup of the joysticks, Error A and Error B LEDs have the identical sequence as the transmitter unit's yellow LED.

<b>Joystick setup:</b>	<b>Led ErrorA e ErrorB (COLOUR)</b>
• <b>Test phase</b>	<i>ON steady (GREEN)</i>
• <b>Setting of the Minimum</b>	<i>Single blink followed by a long pause (RED)</i>
• <b>Setting of the Maximum</b>	<i>Double blink followed by a short pause (RED)</i>
• <b>Setting of the Inversion</b>	<i>Continuous blink (RED)</i>
<b>MORSE CODE</b>	<i>TX error indication (RED)</i>



### 8.7. Transmitting unit power supply

Radio remote controls with portable transmitters are supplied with two rechargeable Ni-Mh batteries and a dedicated battery charger.

### 8.8. Battery status of charge

The battery's status of charge is shown by the YELLOW LED on the transmitting unit.

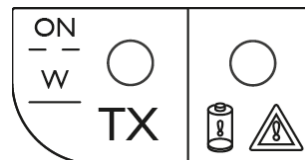

A YELLOW LED OFF means the battery is charged.

A flashing YELLOW LED means the battery is low. Turn off the transmitting unit and change the battery. The LED begins to flash when the battery has power left for approximately 10 to 15 minutes.

**Note:** The yellow LED flashes with the specific sequences during special setup procedures and in the case of system failure.

A low battery charge can also be indicated by an intermittent acoustic warning by connecting a horn to the corresponding relay output on the receiver, which in this case, closes for 1 second every 8 seconds.

### 8.9. Changing and charging the battery

Shut-off the transmitter unit, remove battery from its housing and insert it into the battery charger.

In order to guarantee better battery duration and efficiency, it is best to use the charge until it drains completely.

The battery charger must be powered by a conventional voltage line without significant fluctuations, in order to not affect the smart charging process managed by the microcontroller.

The battery chargers CB36NIMH, CB3600AC e CB3600DC for NiMH cells are equipped with a green LED that indicates that power is present and a yellow LED that flashes 4 times when the battery is inserted (pre-charge) and remains on until charging is complete.

The battery charger is capable of detecting residual charge and battery capacity. The average charge time for a battery that has been properly discharged is 2-3 hours, depending on the residual charge and cell capacity. The charge cycle ends when the yellow LED shuts off.

It is possible that, while charging a battery that was completely empty, the flashing yellow LED phase (pre-charge) lasts several minutes.

**If the flashing persists, clean the golden battery contacts using a soft cloth. If this problem continues, replace the battery with a new one.**

It is best not to interrupt the charging by removing the battery from the housing or by shutting-off the battery charger while the yellow signal LED is still on.

In order to extend battery life cycles, if possible, avoid charging batteries that are already completely or partially charged.

The battery charger is designed for indoor use: do not expose it to the elements. To preserve battery life, recharge the battery in a dry place and at a temperature between 5°C and 35°C (values recommended by NiMH cells manufacturers)

The battery chargers CB37LION for Lipo and Li-ion cells are equipped with a green LED that indicates that power present and a blue LED that, after inserted the battery, if the voltage residual is below of 4,2V, remain on until charging is complete.

The battery charger is capable of detecting residual charge and battery capacity. The average charge time for a battery that has been properly discharged is about 3 hours, depending on the residual charge and cell capacity. The charge cycle ends when the blue LED shuts off.

The battery charger is designed for indoor use: do not expose it to the elements. To preserve battery life, recharge the battery in a dry place and at a temperature between 0°C and 45°C (values recommended by Lipo and Li.-ion cells manufacturers)

**Warning: Explosion hazard if non-compatible batteries are used! Use IMET batteries only. See Chap. 14 for information on the disposal of exhausted batteries.**



## 9. CHANGING THE OPERATING FREQUENCY

If any specific setting has not been made, the radio selects a frequency channel assigned by AFA mode (Automatic Frequency Agility). This mode allows the radio channel change as a result of disturbances detected due to other radio devices operating on the same frequency. There may be cases in which it is preferable to disable the AFA mode, by operating on a fixed channel selected by the operator, doing the procedure described below. In AFA mode, the receiver continuously monitors the frequency band in which it operates and, if the transmission channel becomes too disturbed, the system decides to “move” to the best available channel.



To verify the presence of disturbances, simply turn-off the transmitter and check the “RF-Link” LED on the receiver: if it stays on, it means that other devices are using the same frequency. If disturbances occur during operation, the receiver LEDs “Error\_A” and Error\_B” will turn off to each reception error detected.

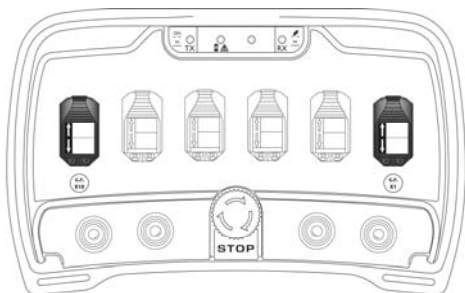

Reception errors lasting more than **passive emergency** preset from 0.5 to 2 seconds, will put the receiver on passive emergency (see § 11.2).

### 9.1. Initial conditions for the frequency change

Make sure the transmitter battery is charged; make sure the receiver is powered and bring the transmitter as close as possible to the receiver.

### 9.2. Frequency change procedure

- Turn on the radio remote control, thus establishing the radio link (the green and blue LEDs on the TX side are blinking and the RF-link LED on the RX side is ON). Press the two frequency change controls (CF) at the same time (see Annex T for identification) and press and release the START button  $\odot$ . The yellow LED on the transmitter will flash at 1s periods and a BUZZER tone will sound.
- Release the two controls (CF): the system turns to AFA mode automatically.

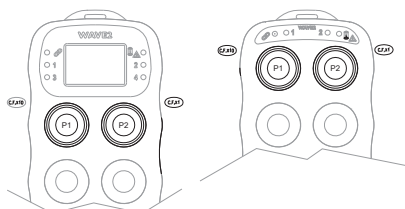
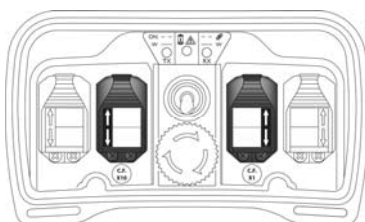
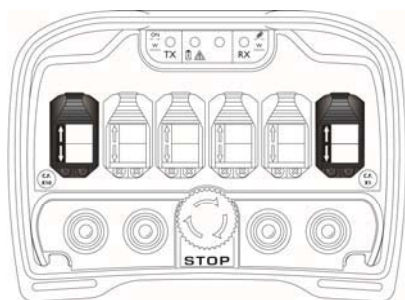

**Select “automatic” Mode:** Press the START button  $\odot$  or, to abort the operation, disconnect the battery pack or, if present, rotate the key selector.

**Select “manual” mode:** To set one of the possible channels, use (C.F.x10) command for the tens and (C.F.x1) command for the units. Press the START button  $\odot$  to memorize the set channel. To abort the operation, disconnect the battery pack or, if present, rotate the key selector counter clockwise. Memorizing a channel exceeding 30 (or channel 69 if RF power is limited to 1mW, or 16 if the radio module is 2,4 GHz) makes the system restart in automatic mode.

At the end of either procedure wait for about 5 seconds: the transmitter and the receiver store the data of the new mode. On the receiver side, you will see the ERROR\_A and ERROR\_B (yellow) LEDs flash briefly: this means the frequency change procedure is being executed.

Press START  $\odot$  to begin the sequence of commands. If it does not occur, it means the procedure was not correctly executed. Turn off all devices and repeat the entire procedure from the beginning.

#### NOTE:

With the 433-434 MHz radio module, when power is set to 10% (1mW) the frequency band and the channels pass automatically from 30 to (band 434.050÷434.775MHz) to 69 channels (band 433.075÷434.775 MHz).

The power level choice (1 or 10 mW) is made by qualified technicians during the radio remote control installation.

### 9.3. Available frequencies (433-434 MHz radio module)

<b>Available Frequencies (69 channels at 1mW / 30 channels at 10mW) ERC REC 70-03</b>					
<b>CHANNEL</b>	<b>FREQUENCY</b>	<b>CHANNEL</b>	<b>FREQUENCY</b>	<b>CHANNEL</b>	<b>FREQUENCY</b>
01	433.075 MHz	24	433.650 MHz	47 (8)	434.225 MHz
02	433.100 MHz	25	433.675 MHz	48 (9)	434.250 MHz
03	433.125 MHz	26	433.700 MHz	49 (10)	434.275 MHz
04	433.150 MHz	27	433.725 MHz	50 (11)	434.300 MHz
05	433.175 MHz	28	433.750 MHz	51 (12)	434.325 MHz
06	433.200 MHz	29	433.775 MHz	52 (13)	434.350 MHz
07	433.225 MHz	30	433.800 MHz	53 (14)	434.375 MHz
08	433.250 MHz	31	433.825 MHz	54 (15)	434.400 MHz
09	433.275 MHz	32	433.850 MHz	55 (16)	434.425 MHz
10	433.300 MHz	33	433.875 MHz	56 (17)	434.450 MHz
11	433.325 MHz	34	433.900 MHz	57 (18)	434.475 MHz
12	433.350 MHz	35	433.925 MHz	58 (19)	434.500 MHz
13	433.375 MHz	36	433.950 MHz	59 (20)	434.525 MHz
14	433.400 MHz	37	433.975 MHz	60 (21)	434.550 MHz
15	433.425 MHz	38	434.000 MHz	61 (22)	434.575 MHz
16	433.450 MHz	39	434.025 MHz	62 (23)	434.600 MHz
17	433.475 MHz	40 (1)	434.050 MHz	63 (24)	434.625 MHz
18	433.500 MHz	41 (2)	434.075 MHz	64 (25)	434.650 MHz
19	433.525 MHz	42 (3)	434.100 MHz	65 (26)	434.675 MHz
20	433.550 MHz	43 (4)	434.125 MHz	66 (27)	434.700 MHz
21	433.575 MHz	44 (5)	434.150 MHz	67 (28)	434.725 MHz
22	433.600 MHz	45 (6)	434.175 MHz	68 (29)	434.750 MHz
23	433.625 MHz	46 (7)	434.200 MHz	69 (30)	434.775 MHz



IMET radio remote controls comply with the specifications of ERC Recommendation 70-03 Annex1 Band F1/F2. The national authorities for telecommunications may impose further restrictions or require use permits in the single countries. All member states allow their free use.

We recommend that you become acquainted with the local laws before using the radio remote control. More information can be found on the following website: <http://www.erodocdb.dk/>

#### 9.4. Available frequencies (2,4 GHz radio module)

Available Frequencies (16 channels DSSS) ERC REC 70-03		
IMET CHANNEL	ERC 70-03 CHANNEL	FREQUENCY
01	11	2405 MHz
02	12	2410 MHz
03	13	2415 MHz
04	14	2420 MHz
05	15	2425 MHz
06	16	2430 MHz
07	17	2435 MHz
08	18	2440 MHz
09	19	2445 MHz
10	20	2450 MHz
11	21	2455 MHz
12	22	2460 MHz
13	23	2465 MHz
14	24	2470 MHz
15	25	2475 MHz
16	26	2480 MHz



IMET radio remote controls comply with the specifications raccomandazione ERC/REC 70-03 Annex1 Band I, Annex 3 Sub-band a. The national authorities for telecommunications may impose further restrictions or require use permits in the single countries. All member states allow their free use.

We recommend that you become acquainted with the local laws before using the radio remote control. More information can be found on the following website: <http://www.erodocdb.dk/>

## 10. DSC (Dynamic Speed Control) Option

When the transmitting unit has the two toggle switches represented in the image here on the right, the DSC function can be used.

Under normal operating conditions, where the snail (reduced speed) function is active, it may be necessary to temporarily correct analog output calibration values without having to enter the programming phase.

For this reason, using a second 3 unstable position toggle switch (+/- toggle switch) it is possible to change reduced speed levels for each joystick in real time, in order to adapt the application's response to the load and precision needs required at the moment.

With the DSC, reduced speed limits may vary within the minimum and maximum limits set in the "hare" mode.



DSC+: increases the reduced speed limit as long as the joystick is at the end of its stroke.

DSC-: decreases the reduced speed limit. In this case joystick position is non influential.

Corrections carried out with the DSC remain valid until the receiver is turned off. (Turning only the transmitting unit off and on will not erase the corrections carried out with the DSC). The next time it is turned on, the system loads from its memory the normal limits that had been previously programmed. The succession of STOP and RUNNING phases issued by the transmitter will not compromise the corrections made with DSC.



During the programming or test phase, the DSC function is not active.  
The DSC function is excluded by the activation of the "Snail-S" mode.

## 11. TROUBLESHOOTING

This chapter contains advice on handling radio remote control malfunctions.



First of all, make sure that the problem actually depends on the remote control. To do so, operate the machine using the wired remote control instead of the radio remote control. The test is valid provided that the same controls are tested and that the radio remote control and the wired remote control use the same connector.



**Any tampering of the radio remote control or its components will automatically void the manufacturer's warranty.**

All repairs should be performed by qualified, authorized personnel and follow the manufacturer's instructions.

Use original spare parts when making replacements, in order to preserve the original features of the radio remote control (see the list of replaceable parts in Chap. 13).

Radio Remote Control	
Problem	Possible Remedies
Limited operating range	<ul style="list-style-type: none"> <li>Check the antenna and move it to a new location if necessary (see Chap. 6)</li> <li>Check the Data Error EC-A and EC_B LEDs and if the system is not in AFA mode, change the frequency (see Chap. 9)</li> </ul>
Certain functions perform improperly	<ul style="list-style-type: none"> <li>See Annexes T and R</li> </ul>
Transmitting Unit	
Problem	Possible Remedies
Transmitting unit does not turn on	<ul style="list-style-type: none"> <li>Check battery charge</li> <li>Make sure no commands are in the working position when you press START</li> <li>Make sure the STOP button is not pressed</li> </ul>
At start-up the LED lights-up only while you press the Start button	<ul style="list-style-type: none"> <li>Check the contacts in the STOP button</li> </ul>
Receiving Unit	
Problem	Possible Remedies
Receiver does not turn on	<ul style="list-style-type: none"> <li>Check the protection fuses</li> <li>Check the power cables</li> </ul>
Receiver turns on but does not activate the application and the green LEDs are on	<ul style="list-style-type: none"> <li>On the receiver, check the fuse in series with the STOP relay and the control relay</li> <li>Check the wiring between the receiver and the application</li> </ul>
Receiver turns on but does not activate the application and the red LEDs are on	<ul style="list-style-type: none"> <li>Check the radio remote control's operating range</li> <li>Make sure the device is not in passive emergency; if so, change the frequency</li> </ul>
Certain commands are not executed	<ul style="list-style-type: none"> <li>Check the wiring between the receiver and the application</li> </ul>
Battery Charger unit	
Problem	Possible Remedies
The green LED does not turn on	<ul style="list-style-type: none"> <li>Check the power cable</li> <li>Check the battery fuse</li> </ul>
Charging lasts only a few minutes	<ul style="list-style-type: none"> <li>Battery is already charged</li> <li>Clean the contacts with a humid cloth</li> </ul>
Battery charger remains in pre-charging phase indefinitely	<ul style="list-style-type: none"> <li>Battery has completed its life cycle</li> <li>Clean the contacts with a humid cloth</li> </ul>



### **11.1. Malfunctions in the transmitter's STOP circuit**

Once you've pressed START  $\Phi$ , in case a malfunction in the STOP circuit is detected, the transmitting unit stops giving the mushroom push-button error code. Please test the radio remote control to verify the functioning of the STOP circuit.

If after having restored the STOP button and pressed START again, the LED flashes and displays the error message "STOP circuit fault", please contact an authorized service center.



### **11.2. Passive Emergency**

Passive emergency is a safety status that the system assumes automatically when it autonomously detects a malfunction (**clause 9.2.7.3 EN 60204-32**). The most common cause is the loss of RF connection between the receiver and the transmitter, for a time previously set from 0.5 to 2 seconds (depending on the analysis risks) due to:

- Strong disturbances on the transmission channel or a significant attenuation of the RF signal caused by an obstacle.
- Excessive distance between transmitter and receiver (out of range).

The receiver enters the passive emergency mode on its own, opens the E-STOP circuit and disables all the commands. In AFA mode, the radio remote control searches a free RF channel with which to establish a valid link, within the predetermined timeout from 0.5 to 2 seconds.

### **11.3. Technical Assistance**

In case of malfunctions in the radio remote control that are not addressed in this manual, contact exclusively a Service Center authorized by the manufacturer.

Call the closest center or the dealer where the device was purchased and provide clearly the following information:

- The radio remote control model
- Serial number
- Defect encountered
- Date of purchase
- Description and history of the problem, status of the receiver and transmitter LEDs during malfunction

Keep this manual and the warranty certificate (filled-out in every part) in a safe place.

## 12. TECHNICAL SPECIFICATIONS

### 12.1. CE Radio module (433-434 MHz)

Manufacturer	<b>IMET S.r.l.</b>
Operating frequency	<b>I.S.M. Band 433.075 - 434.775 MHz <sup>(1)</sup></b>
Modulation	<b>GMSK Dev. 3 KHz</b>
Receiver sensitivity	<b>0.22 uV 12 dB Sinad</b>
F. offset block or desensitization +/- ( 50-1000 KHz)	<b>-40 dBm</b>
F. offset block or desensitization +/- (2 MHz)	<b>-25 dBm (Limit &gt;= -69 dBm clause 9.4 ETSI EN 300-220-1)</b>
F. offset block or desensitization +/- (10 MHz)	<b>-10 dBm (Limit &gt;= -44 dBm clause 9.4 ETSI EN 300-220-1)</b>
Channeling	<b>25 KHz (Half Duplex)</b>
Emission designation	<b>25K0F1D ( 25.0kHz FSK RADIOTELEG.&amp; DATA TRANSMISSION)</b>
Number of programmable channels	<b>30 / 69</b>
RF emission power	<b>&lt;10 mW / &lt; 1mW</b>
Range	<b>~100 m (@10mW)</b>
Channel selection	<b>1) Automatic Mode AFA (Automatic Frequency Agility)</b>
	<b>2) Fixed channel Set by operator</b>
Channeling	<b>25K0F1D ( 25.0kHz FSK RADIOTELEG.&amp; DATA TRANSMISSION)</b>
Transmission mode	<b>Half duplex (telegrams)</b>
Baud Rate on channel	<b>6150 Baud</b>
Hamming distance	<b>≥ 8</b>
Error control	<b>32 bit CRC</b>
Error non-detection probability	<b>&lt;1.832 x 10<sup>-11</sup> (T.B.V.)</b>
Available pairing addresses	<b>131072</b>
Operating temperature range of L type receivers	<b>-25°C to +60 °C (-13°F to +140°F )</b>
Operating temperature range of H type receivers	<b>-25°C to +70 °C (-13°F to +158°F )</b>
Operating temperature range of transmitters	<b>-25°C to +55 °C (-13°F to +131°F )</b>
Storage temperature range	<b>-40°C to +85°C (-40°F to +185 °F)</b>
Marking	<b>CE</b>

NOTE<sup>(1)</sup>

**ISM Band** stands for Industrial, Scientific and Medical Band

### 12.2. CE, FCC, IC, ARIB radio module (2,4 GHz)

Frequency band	<b>I.S.M. Band 2400-2483.5 MHz</b>
Operating frequency	<b>2405- 2480 MHz</b>
Modulation	<b>O-QPSK</b>
MAC protocol	<b>IEEE 802.15.4</b>
Emission designation	<b>2M21F1D</b>
Number of programmable channels	<b>16 (DSSS)</b>
RF emission power	<b>&lt;100 mW</b>
Range	<b>~100 m (@100 mW)</b>
Channel selection	<b>By the operator</b>
Channeling	<b>5 MHz</b>
Modality of data transmission	<b>Half duplex (telegrammi)</b>
Distanza di Hamming	<b>≥ 8</b>
Hamming distance	<b>≥ 8</b>
Error control	<b>32 bit CRC</b>
Error non-detection probability	<b>&lt;1.832 x 10<sup>-11</sup> (T.B.V.)</b>
Available pairing addresses	<b>131072</b>
Operating temperature range of L type receivers	<b>-25°C to +60 °C (-13°F to +140°F )</b>



Operating temperature range of H type receivers  
Operating temperature range of transmitters  
Storage temperature range  
Marking

**-25°C to +70 °C (-13°F to +158°F )**  
**-25°C to +55 °C (-13°F to +131°F )**  
**-40°C to +85°C (-40°F to +185 °F)**  
**CE, FCC, IC, ARIB**

NOTE<sup>(1)</sup>

**ISM Band** stands for *Industrial, Scientific and Medical Band*

### 12.3. Transmitter

Radio module specs. see § 11.1  
Standard commands  
Security KEY

CE Radio module  
**START, HORN, STOP<sup>(1)</sup>**  
**Commands sequence that allow the startup of remote control unit (could be disabled)**  
**Integrated**  
**Radio/Computer<sup>(2)</sup>**

Antenna  
Configuration and diagnostic interface

Safety categories ISO13849-1

**a) STOP circuit PLe Cat. 4**  
(ISO 13849-1:2006 6.2.7 architecture) with a 5A fuse protection

**b) JOYSTICK commands**  
up to **PLd Cat. 3**  
(ISO 13849-1:2006 6.2.6 architecture)

**c) Toggle sw. and push btn commands**  
up to **PLc Cat. 2**  
(ISO 13849-1:2006 6.2.5 architecture)

**d) Toggle sw. and push btn commands**  
up to **PLc Cat. 1**  
(ISO 13849-1:2006 6.2.4 architecture)

Status indicator and error LEDs

- **Green: power on**
- **Yellow: diagnostic**
- **Blue: LINK Status**

Commands / Outputs  
Numbers of panel indicators  
Number of ON/OFF commands  
Number of analog commands  
Max Number of UMFS commands up to PL d, Cat. 3

**56 Max<sup>(3)</sup>**  
**16 Max<sup>(4)</sup>**  
**56 Max<sup>(5)</sup>**  
**16 (19) Max<sup>(5)</sup>**  
**16<sup>(6)</sup> (ISO 13849-1:2006 6.2.6 architecture)**

Display

**Graphic backlight LCD**  
**a) 102x64 pixels monochromatic**  
**b) 128x64 pixels monochromatic**  
**c) 160x64 pixels monochromatic**  
**d) QVGA 3,5" color TFT (optional)**

Beeper  
Backlit panel  
Serial Lines

**internal Buzzer**  
**optional**

- **RS232 o RS485**
- **CAN**
- **Wired control cable**
- **Lean-angle control**

### OPTIONS

- **Dead man function**
- **Safety-ring**
- **IR**
- **Proxy**

**THOR2, ZEUS2, KRON, ARES2, G4L, G4S**

Power supply

**3,6 VDC**

absorption

**<160 mA**

Battery

**Ni-MH 3,6V**

Battery autonomy

**~22 ore (@ 20°C)**

Low Battery notification time

**15 minutes**

Operating temperature range

**-25°C to +55 °C (-13°F to +131°F)**

Storage temperature range

**-40°C to +85°C (-40°F to +185 °F)**

Transmitters housing material

**UL94 HB**

Transmitters housing material G4L

**GFK**

Casing protection degree

**IP65**

Dimensions without LCD display

**M880 THOR2 295x180x160 mm (L.W.H.)**

Dimensions with LCD display

**M880 THOR2 295x250x165 mm (L.W.H.)**

Weight (battery included)

**M880 THOR2 ~2300 g max**

Dimensions without LCD display

**M880 ZEUS2 205x150x150 mm (L.W.H.)**

Dimensions with LCD display

**M880 ZEUS2 205x205x150 mm (L.W.H.)**

Weight (battery included)

**M880 ZEUS2 ~1450 g max**

Dimensions without LCD display

**M880 KRON 180x107x160 mm (L.W.H.)**

Weight (battery included)

**M880 KRON ~880 g max**

Dimensions

**M880 ARES2 143x80x143 mm mm (L.W.H.)**

Weight (battery included)ARES2 E /C

**M880 ARES2 E/C ~667 g max**

Dimensions

**M880 G4L 430x225x180 mm (L.W.H.)**

Weight (battery included)

**M880 G4L ~ 4000 g**

Dimensions

**M880 G4S 265x185x165 mm (L.W.H.)**

Weight (battery included)

**M880 G4S ~ 1950 g**

**WAVE2**

Power supply

**3,7 VDC**

absorption

**80 mA (300 mA with back light on)**

Battery

**Li-Ion 3,7V**

Battery autonomy

**~25 ore (@ 20°C)**

Low Battery notification time

**15 minutes**

Operating temperature range

**-25°C to +55 °C (-13°F to +131°F)**

Storage temperature range

**-40°C to +85°C (-40°F to +185 °F)**

Transmitters housing material

**UL94 HB**

Casing protection degree

**IP65**

Dimensions WAVE2 S6/S8

**72x42x190 mm (W.D.H.)**

Weight (battery included)

**M880 WAVE2 S6/S8 ~235 g max**

Dimensions WAVE2 L10/L12

**72x42x255 mm (W.D.H.)**

Weight (battery included)

**M880 WAVE2 S6/S8 ~315 g max**

**Note:**

(<sup>1</sup>)

Emergency stop mushroom-head pushbutton with turn to reset

(<sup>2</sup>)

The installer using IMET equipment:

- Can make a copy of data stored in the remote radio control



- Can examine the radio control history for errors/faults sequence, operating hours and other functions described in the equipment manual
- Can do the setup of analog commands from a PC (minimum, maximum, speed ramps) and of function commands (interlocks, latching commands, etc.)

(<sup>3</sup>)

Our system is highly flexible in that it allows multiple input configurations, which can satisfy customer requirements: in case of need, an analog input can convert to a digital one and, a digital input can be used as a digital output (e.g. a LED).

(<sup>4</sup>)

Every LED counts as a digital input. It is possible to increase that number using a special board.

(<sup>5</sup>)

Safety categories ISO13849-1 :

Some configuration examples:

- 55 ON/OFF commands, 0 analog commands, 0 LED
- 48 (@ PLc Cat. 1), 7 (@ PLb Cat. b)
- (16 JOYSTICK, 16 Digital x JOYSTICK), 7 auxiliary
- 16 (@PLd,Cat. 3), 7 auxiliary (@ PLb Cat b)
- 16 analog inputs, 16 digital inputs, 7 auxiliary:
- 16AN+16DIG (@PLc Cat1), 7 auxiliary (@PLb Cat b)

(<sup>6</sup>)

UMFS= Unintended Movement From Standstill

## 12.4. M880 HDC / M880 HAC receivers

Radio module specs: see §12.1 and §12.2

Antenna

Receiver turn-on time delay

START time delay

Command response time

Active Emergency intervention time

Passive Emergency intervention time

**Internal/External**

**<2,5 s**

**< 120ms**

**<120 ms**

**<120 ms**

**500ms ≤ t ≤ 2000 ms (<sup>1</sup>)**

Passive **BACKPLANE** system with on board **POWER\_SUPPLY**. Besides the control logic board and the service card, up to 7 modular boards can be inserted customized configuration.

For each receiver:

- 1 LOGIC Board
- 1 SERVICE Board
- 1 USER Board (16 optoisolated digital inputs, 8 analog inputs, 1 CAN, 1 RS232 or RS485)
- 1 Reduced Board (max 6 RELAYS)
- 5 slots for General Purpose boards (DAC, RELS, REL10, REL13)

If a greater number of inputs/outputs is needed, a second (SLAVE) unit can be used. The Slave, deprived of logic and service cards, offers extra room for additional I/O cards. The only drawback/limitation is that, the SAFETY function is implemented by the MASTER system's SAFETY ENABLE relay (not existing a feedback signal).

Number of SAFETY ENABLE RELAYS (N.O.)

**8 (ISO 13849-1:2006 6.2.6 architecture)**

(1 relay on SERVICE board plus 7 relays on cards)

STOP RELAYs (N.C. & N.O)

**2 (ISO 13849-1:2006 6.2.7 architecture )**

TIMED STOP RELAY

**1**

HORN Outputs

**1**

### Feedback:

Serial (Display data on LCD)

**>100 Bytes /s**

Digital (ON/OFF commands)

**128 Max**

Configuration interface (<sup>2</sup>)

Radio link to computer

Diagnostics(<sup>2</sup>)

- On board Status LED or Display
- Laptop or desktop controlled by proprietary IMET equipment

Analog Input (<sup>3</sup>)

**12-bit :**

**Voltage (0..10VDC),**

Digital  
Outputs:(<sup>4</sup>)

**Current (4/20mA, 0/20mA)  
0/24 VDC optoisolated**

**ON/OFF 128 max:**

- Relay (AC e DC);
- MOSFET (DC)

**ANALOG 32 max:**

- Proportional (PWM)
- Analog (current)
- Analog (voltage)

Serial communication interfaces:

**RS232 or RS485 (115200 Baud max)  
CAN\_Bus (ID 11-29 bit)  
CANOpen (ID 11-29 bit)  
Other types on request**

Power supply (AC type)

**45-240Vac, max 1.1A @45Vac, 45VA**

Power supply (AC/DC type )

**11-30Vdc, max 4A @12Vdc, 44W /  
24 Vac (50-60 Hz), max 2,8A , 68VA**

Operating temperature range

**-25°C to +70°C (-13°F to +158 °F)**

Storage temperature range

**-40°C to +85°C (-40°F to +185 °F)**

Housing material

**UL94 V0 5VA, UL 746C (f1)**

Casing protection degree

**IP66**

Dimensions

**205x130x280 mm (L.W.H.)**

Weight (standard configuration)

**≅ 3,5 Kg**

Mounting brackets minimum load (<sup>6</sup>)

**≥120N**

NOTE (1): In referring to EN 60204-32 clause 9.2.7.3, in base to the analyzing risks the installer or the manufacturer of the machine can be set, or ask to be set by specific IMET interface, passive emergency time from 500 to 2000ms.

NOTE (2): Both, the receiver and the diagnosis configurations can be made with an IMET-dedicated interface by radio link. This technique is useful in all those cases when the receiver is not easily accessible, or when you do not want to open the case to access the data port.

NOTE (3): Inputs are managed by the user card SUH. The technical data can be found on the SUH's data sheet.

NOTE (4): Electrical features of COMMANDS. The number shown is the one managed by the logic board; the real number could be limited by physical constraints (i.e. on the mother board it is not possible to mount 4 DAC board for 32 analog outputs)

NOTE (<sup>5</sup>): For versions that do not contemplate the presence of the DAC board, it is possible to have a supply voltage having an extended range

NOTE (<sup>6</sup>): See section 4.2.10 of the Directive IEC 60950-1 2007-02 Wall or Ceiling Mounted Equipment.

Output type	Command type	# of outputs	AC specifications	DC specifications
<b>SERVICE relay board (PCB201 / PCB231)</b>	STOP-relay	2 NO	6A/130-250V AC1	6A/28V DC1
	+	+	+	+
	Safety-relay	1 NO	6A/130-250V AC1	6A/28V DC1
	+	+	+	+
	Relay	3 NC/NO	12A /130-250V AC1	12A/28V DC1
<b>REL10 AC board (PCB232)</b>	Relay	10 NC/NO	12A /130-250V AC1	
<b>REL10 DC board (PCB202)</b>	Relay	10 NC/NO		12A/28V DC1
<b>RELS DC board (PCB203)</b>	Relay	8 NC/NO	6A/130-250V AC1	6A/28V DC1
	+	+		+
	Safety-relay	1 NO		8A/28V DC1
<b>REL13 DC board (PCB204)</b>	Relay	3 NO		12A/28V DC1
		12 NC/NO		
<b>MOS8S board (PCB205)</b>	MOSFET	8		6A/28V (L=0) or
	+	+		2A/28V (L=10mH)
	Safety-relay	1 (NO)		+
				8A/28V DC1
<b>MOS10S board (PCB206)</b>	MOSFET	10		6A/28V (L=0) or
				2A/28V (L=10mH)

<b>MOS12S board (PCB207)</b>	MOSFET	12		6A/28V (L=0) or 2A/28V (L=10mH)
<b>Analog (current) board PWM DAC+C1 (PCB103)</b>	Analog (proportional)	8		0 ÷ 1,4 A ( F= 40÷150Hz; F=200 ÷600Hz; F=600 ÷1000Hz)
<b>Analog ( current) board DAC+C2 (PCB103)</b>	Analog (proportional)	8		0 ÷ 20 mA 4 ÷ 20 mA
<b>Analog (voltage) board DAC+V (PCB103)</b>	Analog (proportional)	8		25% - 50% - 75%Vcc 0Vdc ÷ (Vcc-3) Vccmax=28Vdc -10Vdc to 0Vdc to 10Vdc

### 12.5. M880 LDC / M880 LAC receivers

Radio module specs: see §12.1 and §12.2

For the notes <sup>(1)</sup> and <sup>(2)</sup> see the previous paragraph

Antenna

Receiver power\_up delay

Start command delay

Command response time

Active Stop time

Passive Stop time

SAFETY ENABLE (N.O.) relay(s)

STOP RELAYs (N.C. and N.O)

TIMED RELAY

HORN output

Feedback :

Serial : LCD data

Digital: ON/OFF commands

Configuration interface <sup>(2)</sup>

Radio-Computer link

Diagnostics<sup>(2)</sup>

Analog inputs (12bit resolution)

Digital inputs

Outputs:

Max. number of control relays

Max. number of control relays (N.C./N.O.)

Max. number of service relays (NO)

Max. number of DC command drivers (M880 L-DC only)

Max. number of analog outputs (M880 L-DC only)

Serial communication interfaces:

Power supply voltage (M880 LDC)

Absorbed power

**Internal/External**

**<2,5 s**

**<120 ms**

**<120 ms**

**<120 ms**

**500ms ≤ t ≤ 2000 ms <sup>(1)</sup>**

**1 (ISO 13849-1:2006 6.2.6 architecture)**

**2 (ISO 13849-1:2006 6.2.7 architecture)**

**1**

**1**

**>100 Bytes /s**

**128 Max**

**By means of Status LED / Display or a personal computer using specific IMET equipment**

**4: Voltage (0..10VDC) ,  
Current (4/20mA,0/20mA)**

**8: 0/24 VDC optoisolated**

**20**

**4 (with relay boards mod. RLC)**

**14 (with boards mod. RDC)**

**3 (START, CLAXON and T-RELAY)**

**20 (MOSFET)**

**8 Proportional (PWM),  
Analog current and/or  
Analog voltage**

**RS232 (max 115200 Baud)**

**CAN\_Bus (ID 11-29 bit) (1Mbit/s max)**

**CANOpen (ID 11-29 bit) (1Mbit/s max)**

**11 - 30 Vdc**

**22W Max**

Maximum absorption

≈ 2A max @ 11Vdc

Power supply voltage (M880 LAC)

24-55 Vac / 100-240 Vac (50-60 Hz)

Absorbed power

30 VA Max

Maximum absorption

≈ 1.2A Max @ 24Vac

Operating temperature range

-25°C to +60°C (-13°F to +140 °F)

Storage temperature range

-40°C to +85°C (-40°F to +185 °F)

Housing material

UL94 V0 5VA, UL 746C (f1)

Casing protection degree

IP66

Dimensions

140x65x230 mm (L.W.H.)

Weight (standard configuration)

≈ 1,700 Kg

Mounting brackets minimum load

≥100N

Output type	Command type	# of outputs	AC specifications	DC specifications
<b>M880 LDC mother board (PCB100)</b>	STOP relay + Safety-enable relay + Relay	2 NO + 1 NO + 3 NC/NO	6A/130250V AC1 + 6A/130-250V AC1 + 12A /130-250V AC1	6A/28V DC1 + 6A/28V DC1 + 12A/28V DC1
<b>M880 LAC mother (PCB130)</b>	STOP relay + Safety-enable relay + Relay	2 NO + 1 NO + 1 NC/NO	6A/130250V AC1 + 6A/130-250V AC1 + 12A /130-250V AC1	6A/28V DC1 + 6A/28V DC1 + 12A/28V DC1
<b>Relay board for LAC receiver (PCB131)</b>	Relay	16 NO + 4 NC/NO	8A/130-250V AC1	
<b>Relay board for LDC receiver (PCB101)</b>	Relay	2 NO + 14 NC/NO		12A/28V DC1
<b>Relays board for LDC receiver</b>	Relay	14 NO		16A/28V DC1
<b>ON/OFF MOSFET for LDC receiver (PCB102)</b>	MOSFET	20		6A/28V (L=0) or 2A/28V (L=10mH)
<b>H motor driver per LDC receiver (PCB110)</b>	H-bridge motor driver	2		12A / 24V
<b>ON/OFF MOSFET + ANALOG OUT for LDC receiver (PCB104)</b>	MOSFET / Analog (proportional)	6 / 4		6A/28V (L=0) 2A/28V (L=10mH) 0 -1,4 A ( F= 40-150Hz; F=200-600Hz F=600-1000Hz)
<b>Analog current board PWM ADD+C1 (PCB103)</b>	Analog (proportional)	8		0 -1,4 A ( F= 40-150Hz; F=200-600Hz F=600-1000Hz)
<b>Analog current board ADD+C2 (PCB103)</b>	Analog (proportional)	8		0 - 20 mA 4 - 20 mA
<b>Analog voltage board ADD+V1 (PCB103)</b>	Analog (proportional)	8		25% - 50% - 75%Vcc 0Vdc - (Vcc-3) Vccmax=28Vdc -10Vdc to 0Vdc to 10Vdc

## 12.6. M880 MAC receivers

Radio module specs: see §12.1 and §12.2

For the notes <sup>(1)</sup> and <sup>(2)</sup> see the previous paragraph

Antenna	<b>Internal/External</b>
Receiver power_up delay	<b>&lt;2,5 s</b>
Start command delay	<b>&lt;120 ms</b>
Command response time	<b>&lt;120 ms</b>
Active Stop time	<b>&lt;120 ms</b>
Passive Stop time	<b>500ms ≤ t ≤ 2000 ms <sup>(1)</sup></b>
SAFETY ENABLE (N.O.) relay(s)	<b>1 (ISO 13849-1:2006 6.2.6 architecture)</b>
STOP RELAYs (N.C. and N.O)	<b>2 (ISO 13849-1:2006 6.2.7 architecture)</b>
HORN output	<b>1</b>
Lamp output	<b>1</b>
Feedback :	
Serial : LCD data	<b>&gt;100 Bytes /s</b>
Digital: ON/OFF commands	<b>128 Max</b>
Configuration interface <sup>(2)</sup>	
Radio-Computer link	
Diagnostics <sup>(2)</sup>	
	<b>By means of Status LED / Display or a personal computer using specific IMET equipment</b>
Analog inputs (12bit resolution)	<b>4 Voltage (0-10VDC), Current (4-20mA, 0-20mA)</b>
Digital inputs	<b>8 0-24 VDC optoisolated</b>
Outputs:	
Max. number of control relays	<b>22 (18 N.O. and 4 N.C./N.O.)</b>
Max. number of service relays (NO)	<b>2 (START, LAMP)</b>
Max. number of analog outputs	<b>4 Analog current (NOT PWM )and/or Analog voltage</b>
Serial communication interfaces:	
	<b>RS232/RS485 (115200 Baud max) CAN_Bus (ID 11-29 bit) (1Mbit/s max) CANOpen (ID 11-29 bit) (1Mbit/s max)</b>
Power supply voltage	<b>12-30 Vdc / 24 Vac (50-60 Hz)</b>
Absorbed power	<b>22W Max</b>
Maximum absorption	<b>≅ 2A max @ 11Vdc</b>
Operating temperature range	<b>-25°C to +70°C (-13°F to +158 °F)</b>
Storage temperature range	<b>-40°C to +85°C (-40°F to +185 °F)</b>
Housing material	<b>ABS</b>
Casing protection degree	<b>IP20</b>
Dimensions	<b>180x120x73 mm (L.D.H)</b>
Weight (standard configuration)	<b>≅ 0,91 Kg</b>
Mounting brackets minimum load	<b>≥50N</b>

Output type	Command type	# of outputs	AC specifications	DC specifications
<b>MAC mother board (PCB300)</b>	STOP relay + Safety-enable relay	2 NO + 1 NO	6A/130V AC1 + 6A/130V AC1	6A/28V DC1 + 6A/28V DC1
<b>MAC mother board (PCB300)</b>	Command Relays	18 NO + 4 NC/NO	6A/130V AC1 + 6A/130V AC1	6A/28V DC1
<b>MAC mother board (PCB300)</b>	START relay, LAMP relay	2 NO	6A/130V AC1 + 6A/130V AC1	6A/28V DC1
<b>Analog current board ADD+C2 (PCB301)</b>	Analog (proportional)	4		0 - 20 mA 4 - 20 mA
<b>Analog voltage board ADD+V1 (PCB301)</b>	Analog (proportional)	4		25% - 50% - 75%Vcc 0Vdc - (Vcc-3) Vccmax=12Vdc -10Vdc to 0Vdc to 10Vdc

### 12.7. CB3600-AC, CB3600-DC battery charger for THOR2, ZEUS2, ARES2 and KRON transmitters

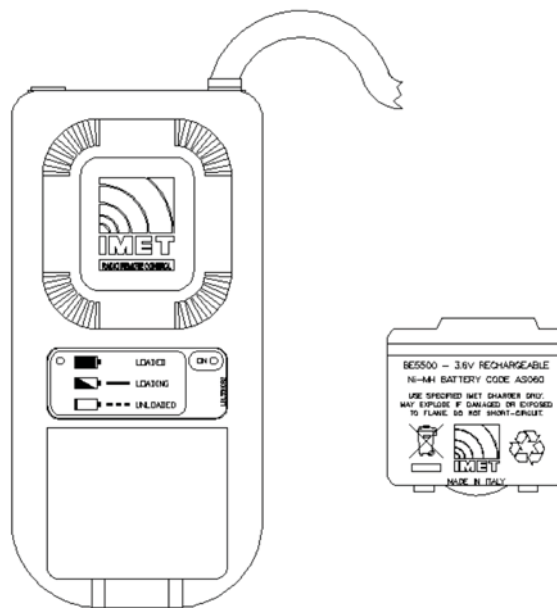

- Power supply voltage
- Power demand
- Charging current
- IMET battery
- Max charging time
- Type of charge
- Casing protection degree
- Operating temperature during charge
- Storage temperature (charger off and without battery)
- Housing material
- Dimensions
- Weight
- Weight including 230V AC transformer (optional)

**12-32V DC (85-230V AC optional)**  
**35mA AC/250mA DC (during charge)**  
**≈ 650mA**  
**Ni-MH 3.6V 1.7 A/h**  
**3 hours**  
**PVD**  
**IP30**  
**0°C to +35°C (+32°F to +95 °F)**  
**-40°C to +85°C (-40°F to +185 °F)**  
**UL94 V0**  
**75x49x156 mm (L.W.H.)**  
**250 g**  
**491 g**



## 12.8. CB36NIMH Battery charger for THOR2, ZEUS2, ARES2 and KRON transmitters

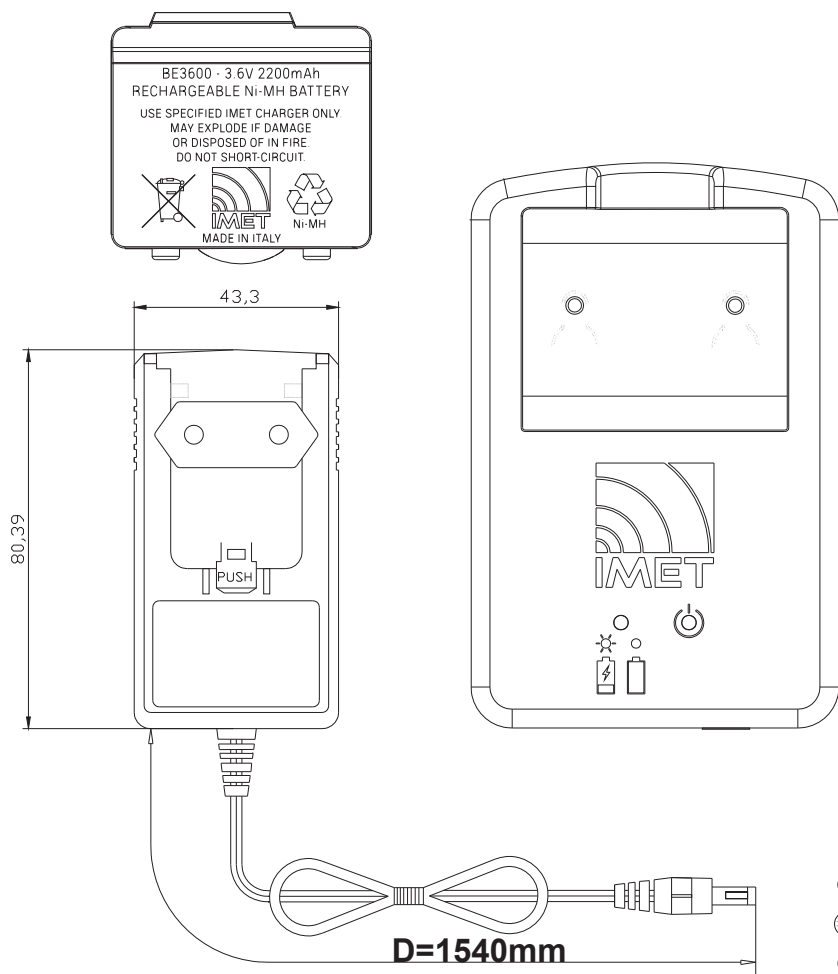

Power supply voltage	<b>12-24 Vdc (min 11Vdc – max 30Vdc)</b>
Power demand	<b>400mA max DC (during charge)</b>
Charging current	<b>≈ 900mA</b>
IMET battery (BE3600)	<b>Ni-MH 3.6V 2.2 Ah</b>
Max. charging time	<b>2.45 hours</b>
Type of charge	<b>PVD</b>
Operating temperature during charge	<b>0°C to +35°C (+32°F to +95 °F)</b>
Storage temperature (charger off and without battery)	<b>-40°C to +85°C (-40°F to +185 °F)</b>
Housing material	<b>UL94 V0, UL746C (f1)</b>
Casing protection degree	<b>IP20</b>
Dimensions	<b>80x30x120 mm (L.W.H.)</b>
Weight	<b>250g</b>

**Note:** A Battery Charger kit comes with an external EU power plug (US, UK or AUS on request). On request, a power cord for the cigarette lighter-type plug can be supplied.

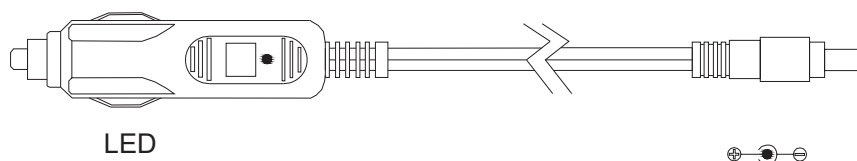

## 12.9. CB36NIMH G4 - Battery charger M880 G4L and M880 G4S transmitters

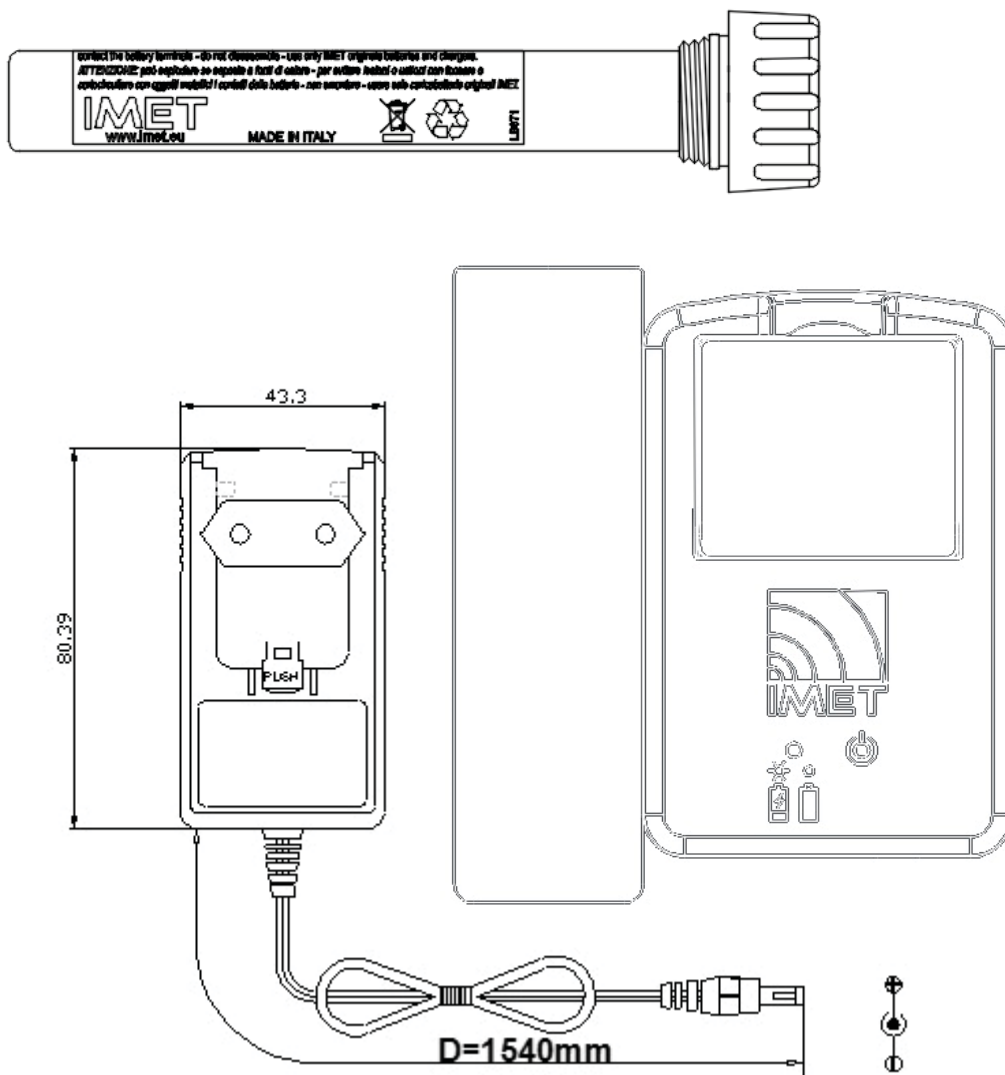

Power supply voltage	<b>12-24 Vdc (min 11Vdc – max 30Vdc)</b>
Power demand	<b>400mA max DC (during charge)</b>
Charging current	<b>≈ 900mA</b>
IMET battery (BE3600)	<b>Ni-MH 3.6V 2.1 Ah</b>
Max. charging time	<b>2.35 hours</b>
Type of charge	<b>PVD</b>
Operating temperature during charge	<b>0°C to +35°C (+32°F to +95 °F)</b>
Storage temperature (charger off and without battery)	<b>-40°C to +85°C (-40°F to +185 °F)</b>
Housing material	<b>UL94 V0, UL746C (f1)</b>
Casing protection degree	<b>IP20</b>
Dimensions	<b>120x40x137 mm (L.W.H.)</b>
Weight	<b>344g</b>

**Note:** A Battery Charger kit comes with an external EU power plug (US, UK or AUS on request). On request, a power cord for the cigarette lighter-type plug can be supplied.

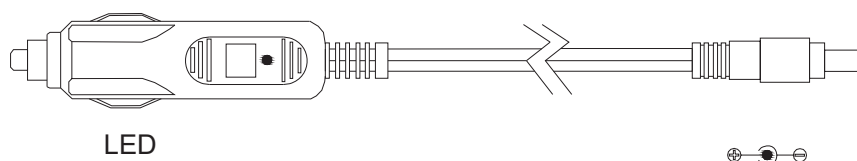



## 12.10. CB37LION battery charger for WAVE2 transmitters

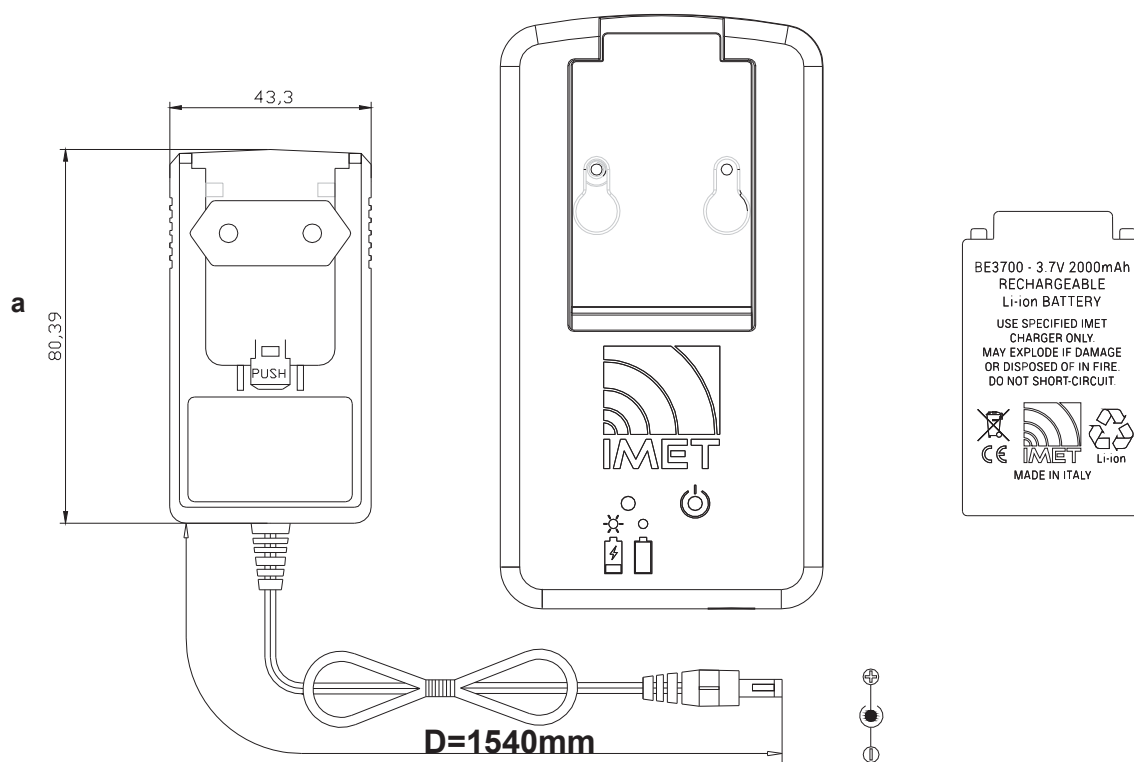

Power supply voltage	<b>12-24 Vdc (min 11Vdc – max 30Vdc)</b>
Power demand	<b>0.3A 3.3 W (during charge)</b>
Charging current	<b>≈ 540mA</b>
IMET battery (BE3700)	<b>Lipo 3.7V 2.0 Ah</b>
Max. charging time	<b>2.45 hours</b>
Type of charge	<b>TTDM (JEITA range)</b>
Operating temperature during charge	<b>0°C to +45°C (+32°F to +113 °F)</b>
Storage temperature (charger off and without battery)	<b>-40°C to +85°C (-40°F to +185 °F)</b>
Case material	<b>UL94 V0, UL746C (f1)</b>
Casing protection degree	<b>IP20</b>
Dimensions	<b>70x25x130 mm (L.W.H.)</b>
Weight (power supply not included)	<b>110g</b>

**Note:** A Battery Charger kit comes with an external EU power plug (option US, UK or AUS on request). As option, a 6-feet AUTO POWER CORD can be delivered.

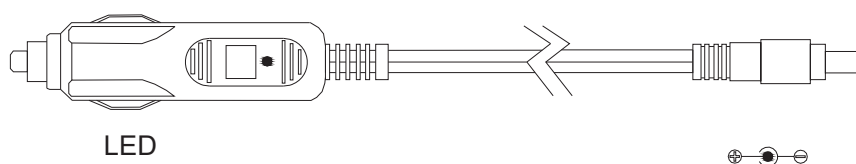

## 13. RADIO REMOTE CONTROL SPARE PARTS LIST

### 13.1. Transmitting units and battery charger

Description	Item code
Battery charger CB3600-AC 230 Vac with italian plug	CR016
Battery charger CB3600-AC 230 Vac with Shuko plug(CEE 7/4)	CR017
Battery charger CB3600-DC 12 - 32 Vdc	CR018
Battery 3.6V 1.7 A/h Ni-MH	AS060
F1 fuse 5x20 T 50mA L250V for CB3600-AC	FS031
F1 fuse 5x20 T 1,25 A L250V for CB3600-DC	FS002
Battery charger CB36NIMH ARES2, KRON, ZEUS2 and THOR2	CR040
Batt. BE3600 NiMH 2.2Ah for M880 ARES2, KRON, ZEUS2 and THOR2	AS083
Battery charger CB37LION for WAVE2	CR039
Battery BE3700 Lipo 2.00 Ah for M880 WAVE2	AS087
Battery charger CB36NIMH G4	CR041
Batt. BE3600G4 NiMH 2.1Ah for M880 G4 L/S	AS088

### 13.2. HDC Receiver

Description	Item code	Remarks
F1 fuse 5x20 T 5A L250V	FS005	RX H DC(PCB200)
F1 fuse 5x20 T 6,3A L250V	FS006	RELS(PCB203)
F1 fuse 5x20 T 5A L250V	FS005	SERVDC(PCB201)
F2 fuse 5x20 T 5A L250V	FS005	SERVDC(PCB201)
F3 fuse 5x20 T 5A L250V	FS005	SERVDC(PCB201)
F1 fuse 5X20 T 6,3A	FS006	MOSFET(PCB206)

### 13.3. HAC Receiver

Description	Item code	Remarks
F1 fuse 5X20 T 1,6A	FS045	RX H AC(PCB230)
F1 fuse 5x20 T 6,3A L250V	FS006	RELS(PCB232)
F1 fuse 5x20 T 5A L250V	FS005	SERVDC(PCB231)
F2 fuse 5x20 T 5A L250V	FS005	SERVDC(PCB231)
F3 fuse 5x20 T 5A L250V	FS005	SERVDC(PCB231)

### 13.4. LDC Receiver

Description	Item code	Remarks
F1 fuse 5x20 T 4A L250V	FS041	RX L DC(PCB100)
F2 fuse 5x20 T 5A L250V	FS005	RX L DC(PCB100)
F3 fuse 5x20 T 5A L250V	FS005	RX L DC(PCB100)
F4 fuse 5x20 T 5A L250V	FS005	RX L DC(PCB100)

### 13.5. LAC Receiver

Description	Item code	Remarks
F1 fuse 5x20 T 1.6A L250V	FS045	RX L AC(PCB130)
F2 fuse 5x20 T 5A L250V	FS005	RX L AC(PCB130)
F3 fuse 5x20 T 5A L250V	FS005	RX L AC(PCB130)
F4 fuse 5x20 T 5A L250V	FS005	RX L AC(PCB130)

### 13.6. MAC Receiver

<b>Description</b>	<b>Item code</b>	<b>Remarks</b>
<i>F1 fuse 5x20 T 5A L250V</i>	<i>FS005</i>	<i>RX DIN (PCB301)</i>
<i>F2 fuse 5x20 T 5A L250V</i>	<i>FS005</i>	<i>RX DIN (PCB301)</i>
<i>F3 fuse 5x20 T 1.25A L250V</i>	<i>FS002</i>	<i>RX DIN (PCB301)</i>

## 14. DISPOSAL (EU zone)

---

Once no longer in use, the radio remote control should be handed over to the local waste disposal service.



The symbol of the crossed-out waste container on the device means that it must be handled separately from normal waste. The owner is responsible for handing over scrapped equipment to the designated points of collection for the recycling of electric or electronic waste material.



Waste separation contributes to protecting the environment and facilitates recycling.

Exhausted batteries should be disposed of at the specific points of collection, as required by law.

Illegal disposal of the product is punished (in Italy) by the penalties indicated in the Legislative Decree no. 22/1997 (Art. 50 and subs.) implementing the European Directive 2002/96/CE.

## 15. ANNEXES

---

This manual is completed by the following annexes, indicating specific information on the project number by which the radio remote control is identified.

### **Annex T**

Arrangement and electric symbols of the actuators in the transmitting unit.

### **Annex R**

Wiring diagram of the outputs in the receiving unit.

### **Other annexes**

Special functions

*No part of this manual may be reproduced in any way without written authorization from IMET. This manual is subject to change with no further notice. Every possible care has been taken in compiling and verifying the contents of this manual; however, IMET declines any responsibility deriving from using the manual or from any errors or omissions in the information contained herein. Furthermore, IMET cannot be held responsible for damages or problems deriving from using non-original accessories or spare parts. The same applies to any person or company involved in the realization of this manual.*



**IMET** s.r.l.  
Via Fornace, 8  
33077 Sacile (PN) Italy  
Tel. +39 0434 7878  
Fax +39 0434 737848  
[www.imet.eu](http://www.imet.eu) - [info@imet.eu](mailto:info@imet.eu)

