

RES-401

Operating Instructions



Important features

- Automatic zero calibration (AUTOCAL)
- Automatic optimization (AUTOTUNE)
- Automatic configuration of the secondary voltage and current ranges (AUTORANGE, as of October 2005)
- Automatic frequency adjustment
- Set point selection with potentiometer
- Temperature range: 300°C
- 0...10VDC analog output for ACTUAL temperature
- Activated with contact or 24VDC signal
- Alarm function

Contents

1	General information	3	6	Controller functions	14
1.1	Intended use	3	6.1	Indicators and controls	14
1.2	Heatsealing band	3	6.2	Temperature setting (set point selection)	15
1.3	Impulse transformer	3	6.3	Temperature indication (actual value output)	16
1.4	Current transformer PEX-W3/-W4	3	6.4	Automatic zero calibration (AUTOCAL)	17
1.5	Line filter	4	6.5	"START" signal (HEAT)	18
1.6	Standards / CE marking	4	6.6	Diagnostic interface/visualization software (as of October 2005)	19
1.7	Maintenance	4	6.7	System monitoring/alarm output	19
1.8	Disposal	4	6.8	Error messages	19
2	Application	4	6.9	Fault areas and causes	19
3	Principle of operation	5	7	Factory settings	21
4	Traits of the controller	5	8	Technical data	22
5	Installation	5	9	Dimensions	23
5.1	Installation procedure	5	10	Modifications (MODs)	23
5.2	Installation steps	6	11	How to order	24
5.3	Power supply	7	12	Index	25
5.4	Line filter	8			
5.5	Current transformer PEX-W3/-W4	8			
5.6	Wiring diagram	9			
5.7	Startup and operation	10			
5.8	View of the controller	10			
5.9	Controller configuration	10			
5.10	Replacing and "burning in" the heatsealing band	11			
5.11	Startup procedure	12			

1 General information

This RESISTRON temperature controller is manufactured according to EN 61010-1. In the course of its manufacture it passed through quality assurance, whereby it was subjected to extensive inspections and tests. As a result of this, the product left our factory in perfect condition.

The recommendations and warning notes contained in these operating instructions must be complied with, in order to guarantee safe operation.

The device can be operated within the limits indicated in the "Technical Data" without impairing its operational safety. Installation and maintenance may only be performed by technically trained, skilled persons who are familiar with the associated risks and warranty provisions.

1.1 Intended use

RESISTRON temperature controllers may only be used for heating and temperature control of heatsealing bands which are expressly approved for them, and providing the regulations, notes and warnings contained in these instructions are observed.

In case of non-observance or use contrary to the intended purpose, there is a risk that safety will be impaired or that the heatsealing band, electrical wiring, transformer etc. will overheat. This is the personal responsibility of the user.

1.2 Heatsealing band

The use of suitable heatsealing bands is a basic prerequisite for reliable and safe operation of the system.

The resistance of the heatsealing band which is used must have a positive minimum temperature coefficient in order to guarantee trouble-free operation of the RESISTRON temperature controller.

The temperature coefficient must be specified as follows:

$$TCR \geq 10 \times 10^{-4} \text{ K}^{-1}$$

e.g. Alloy-20: TCR = 1100 ppm/K
 NOREX: TCR = 3500 ppm/K

The RESISTRON temperature controller must be set and coded according to the temperature coefficient of the heatsealing band.



The use of incorrect alloys with a too low temperature coefficient and incorrect coding of the RESISTRON temperature controller leads to uncontrolled heating of the heatsealing band, which will ultimately burn out!

The original heatsealing bands must be clearly identified by means of suitable markings as well as the connector geometry, length, or other means to ensure that replacement bands are identical.

1.3 Impulse transformer

A suitable impulse transformer is necessary in order to guarantee trouble-free operation of the control loop. This transformer must be designed according to EN 61558 (isolating transformer with reinforced insulation) and have a one section bobbin. When the impulse transformer is installed, suitable touch protection must be provided in accordance with the national installation regulations for electrical equipment. In addition to this, water, cleaning solutions and conductive fluids must be prevented from seeping into the transformer.

Incorrect installation of the impulse transformer impairs electrical safety.

1.4 Current transformer PEX-W3/-W4

The current transformer supplied with the RESISTRON temperature controller is an integral part of the control system.

Only the original ROPEX PEX-W2, PEX-W3 or PEX-W4 current transformer may be used. Other transformers may cause the equipment to malfunction.

The current transformer may only be operated if it is correctly connected to the RESISTRON temperature controller (see section "Startup and operation"). The relevant safety instructions contained in section "Power supply", must be observed. External monitoring modules can be used in order to additionally increase operating safety. They are not included in the scope of supply of the standard control system and are described in a separate document.

1.5 Line filter

The use of an original ROPEX line filter is mandatory in order to comply with the standards and provisions mentioned in section 1.6 "Standards / CE marking" on page 4. This device must be installed and connected according to the instructions contained in section "Power supply" as well as the separate documentation enclosed with the line filter.

1.6 Standards / CE marking

The controller described here complies with the following standards, provisions and directives:

DIN EN 61010-1:2001 (2014/35/EU)	Safety requirements for electrical equipment for measurement, control and laboratory use (low-voltage directive): pollution degree 2, protection class I, measurement category I (for U_R and I_R terminals)
DIN EN 60204-1 (2006/42/EG)	Electrical equipment of machines (machinery directive)
EN 55011:2009+A1:2010 EN 61000-3-2:2006-04+ A1:2009+A2:2009 EN 61000-3-3:2008 EN 61000-6-4:2007+ A1:2011 (2014/30/EU)	EMC genery emissions: Group 1, Class A
EN 61000-6-2:2005 (2014/30/EU)	EMC generic immunity: Class A (ESD, RFI, burst, surge) <u>Exception:</u> Line voltage interruption acc. to EN 61000-4-11 is not fulfilled (This leads to a designated error message of the controller)

Compliance with these standards and provisions is only guaranteed if original accessories and / or peripheral components approved by ROPEX are used. If not, then the equipment is operated on the user's own responsibility.

2 Application

This RESISTRON temperature controller is an integral part of the "Series 400", the outstanding feature of which is its microprocessor technology. All RESISTRON temperature controllers are used to control the temperature of heating elements (heatsealing bands, beaded bands, cutting wires, heatsealing blades,

The CE marking on the controller confirms that the device itself complies with the above-mentioned standards.

It does not imply, however, that the overall system also fulfils these standards.

It is the responsibility of the machine manufacturer and of the user to verify the completely installed, wired and operationally ready system in the machine with regard to its conformity with the safety provisions and the EMC directive (see also section "Power supply"). If peripheral components (e.g. the transformer or the line filter) from other manufacturers are used, no functional guarantee can be provided by ROPEX.

1.7 Maintenance

The controller requires no special maintenance. Regular inspection and / or tightening of the terminals – including the terminals for the winding connections on the impulse transformer – is recommended. Dust deposits on the controller can be removed with dry compressed air.

1.8 Disposal

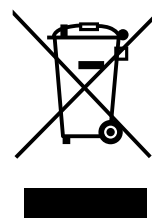

This device is subject to Directive 2012/19/EU concerning the reduction of the increasing amount of waste electrical and electronic equipment and the disposal of uch waste in an environmentally sound way.

It must not be disposed of as residual wase! To guarantee proper disposal and / or the recover of reusable material, please take the device to adesignated municipal collectin point and observe local regulations.

Careless, uncontrolled disposal can cause damage to the environment and human health. By ensuring that your product is disposed of or recycled in a responsible way, you can help protect the environment and human health.

solder elements etc.), as required in a variety of heat-sealing processes.

The controller is most commonly used for impulse-heatsealing PE films in:

- Vertical and horizontal f/f/s machines

- Pouch, filling and sealing machines
- Film wrapping machines
- Pouch-making machines
- Group packaging machines
- etc.

3 Principle of operation

The resistance of the heatsealing band, which is temperature-sensitive, is monitored 50x per second (60x at 60Hz) by measuring the current and voltage. The temperature calculated with the help of these measurements is displayed and compared with the set point.

The primary voltage of the impulse transformer is adjusted by phase-angle control, if the measured values deviate from the set point. The resulting change in the current through the heatsealing band leads to a change in the band temperature and thus also its resistance. This change is measured and evaluated by the RESISTRON temperature controller.

The control loop is closed: ACTUAL temperature = SET temperature. Even minute thermal loads on the heatsealing band are detected and can be corrected quickly and precisely.

A highly high response thermo-electric control loop is formed which is highly accurate because purely electrical variables are measured at a high sampling rate. A high secondary current can be controlled because power is controlled on the primary side of the transformer. This allows optimum adaptation to the load and to the required dynamic range despite the exceptionally compact dimensions of the controller.

4 Traits of the controller

- Very simple operation thanks to AUTOCAL, the automatic zero calibration function.
- Good dynamic response of the control system thanks to AUTOTUNE, which adapts automatically to the controlled system.
- High precision thanks to further improved control accuracy and linearization of the heatsealing band characteristic.
- High flexibility: The AUTORANGE function (as of October 2005) covers a secondary voltage range from 0.4V to 120V and a current range from 30A to 500A.
- Automatic adjustment to the line frequency in the range from 47Hz...63Hz.
- Increased protection against dangerous conditions, such as overheating of the heatsealing band.

The ACTUAL temperature of the heatsealing band is supplied to an analog 0...10VDC output. The real heatsealing band temperature can thus be displayed on an external temperature indicator (e.g. ATR-3).

The RESISTRON temperature controller RES-401 features an integrated fault diagnosis function, which tests both the external system (heatsealing band, wiring etc.) and the internal electronics and indicates a fault by means of the LED.

To increase operational safety and interference immunity, all 24VDC logic signals are electrically isolated from the controller and the heating circuit.

The compact design of the RESISTRON temperature controller RES-401 and the plug-in connections make this controller easy to install.

5 Installation

↪ See also section 1 "General information" on page 3.

 **Installation and startup may only be performed by technically trained, skilled persons who are familiar with the associated risks and warranty provisions.**

5.1 Installation procedure

Proceed as follows to install the RESISTRON temperature controller RES-401:

1. Switch off the line voltage and verify that the circuit is de-energized.
2. The supply voltage specified on the nameplate of

the RESISTRON temperature controller must be identical to the line voltage that is present in the plant or machine. The line frequency is automatically detected by the RESISTRON temperature controller in the range from 47Hz...63Hz.

3. Install the RESISTRON temperature controller in the electrical cabinet on a standard top hat rail (DIN TS35 rail, according to DIN EN 50022). If several controllers are installed on one top hat rail, the minimum clearance specified in section 8 "Technical data" on page 22 must be allowed between them.
4. Wire the system in accordance with the instructions

in section 5.3 "Power supply" on page 7, section 5.6 "Wiring diagram" on page 9 and the ROPEX Application Report. The information provided in section 5.2 "Installation steps" on page 6 must also be heeded additionally.

⚠ Check the tightness of all the system connections, including the terminals for the impulse transformer windings.

5. Make sure that the wiring conforms to the relevant national and international installation regulations.

5.2 Installation steps

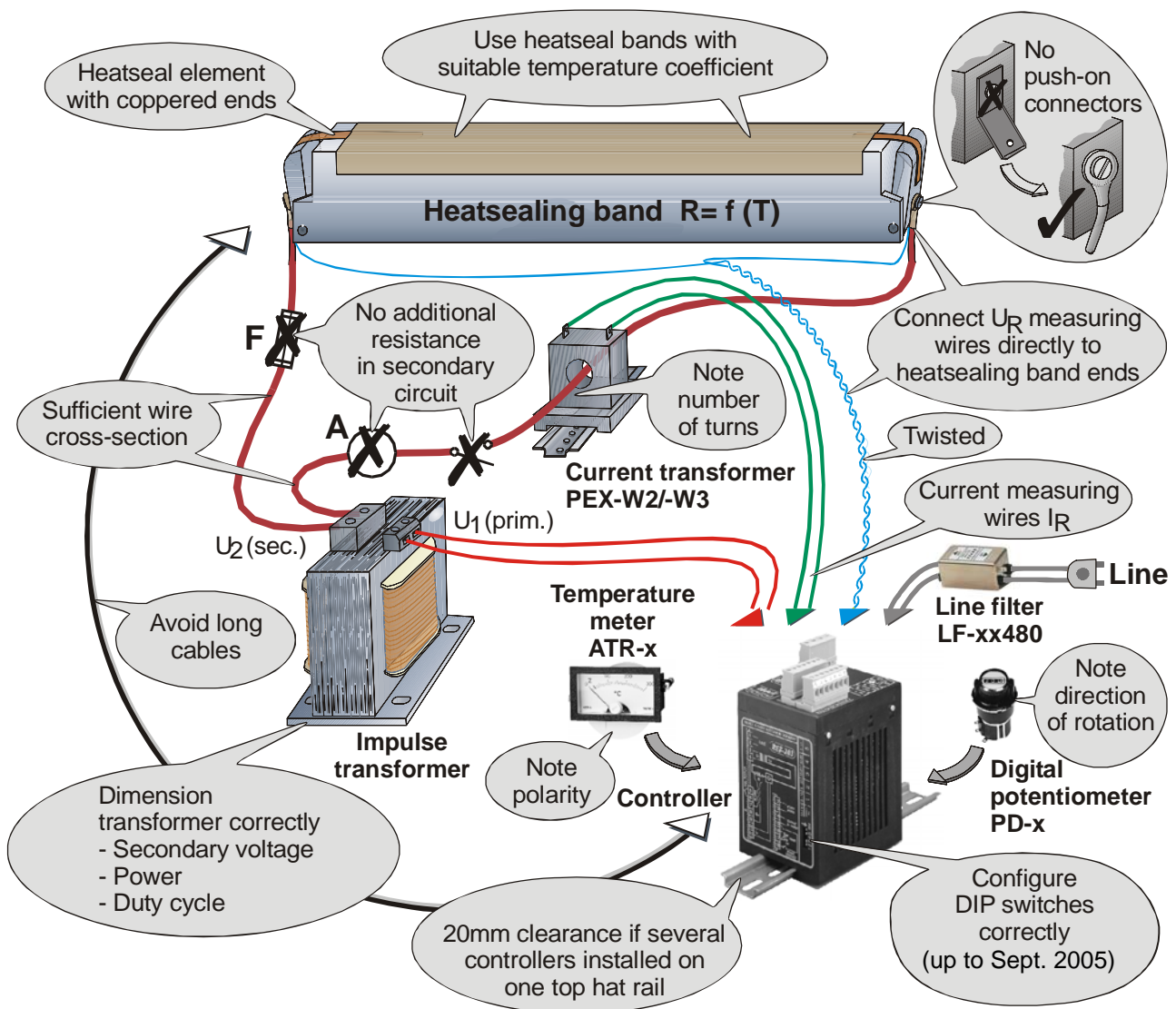

5.3 Power supply

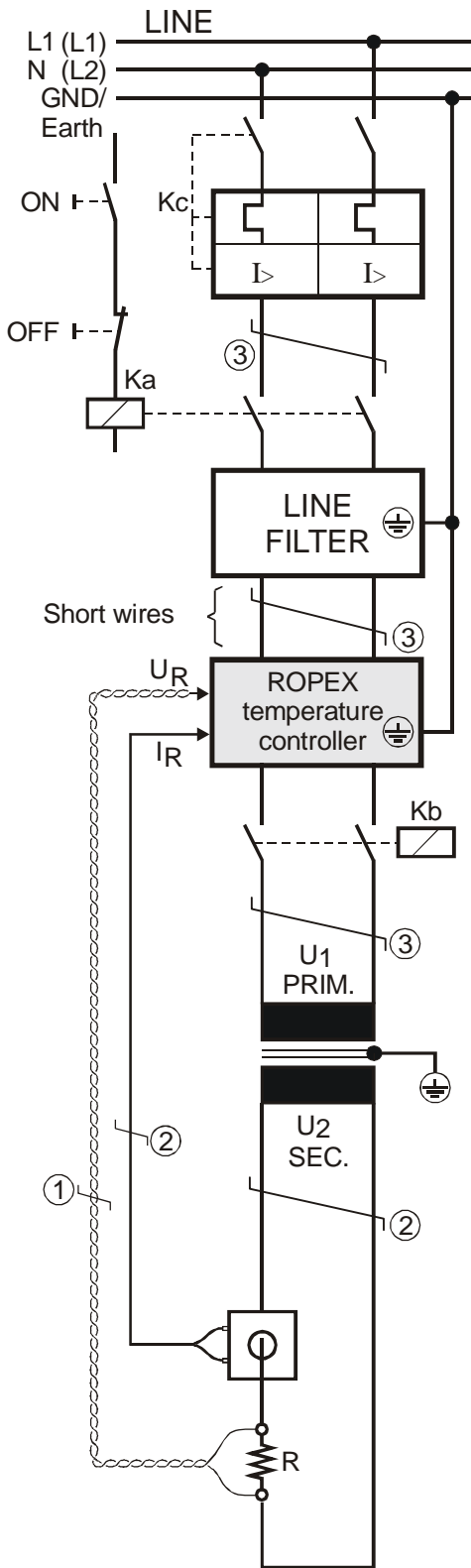

Line

115 VAC, 230 VAC, 400 VAC
50/60 Hz

Over-current protection

Double-pole circuit-breaker or fuses,
(☞ ROPEX Application Report)

⚠ Short-circuit protection only.
RESISTRON temperature controller not protected.

Relay Ka

For "HEAT ON - OFF" function (all-pole) or "EMERGENCY STOP".

Line filter

The filter type and size must be determined according to the load, the transformer and the machine wiring (☞ ROPEX Application Report).

⚠ Do not run the filter supply wires (line side) parallel to the filter output wires (load side).

RESISTRON temperature controller

Relay Kb

Load break (all-pole), e.g. in combination with the alarm output of the temp. controller (ROPEX recommendation).

⚠ When using a series resistor RV-....-1 the relay Kb shall be installed.

Impulse Transformer

Designed according to EN 61558 (isolating transformer with reinforced insulation). Connect core to ground.

⚠ Use transformers with a one section bobbin. The power, duty cycle and voltage values must be determined individually according to the application (☞ ROPEX Application Report and "Accessories" leaflet for impulse transformers).

Wiring

The wire cross-sections depend on the application (☞ ROPEX Application Report).

- ① Wires must always be twisted (min. 20 turns/meter).
- ② These wires must be twisted (min. 20 turns/meter) if several control loops are laid together ("crosstalk").
- ③ Twisting (min. 20 turns/meter) is recommended to improve EMC.

5.4 Line filter

To comply with EMC directives – corresponding to EN 50081-1 and EN 50082-2 – RESISTRON control loops must be operated with line filters.

These filters damp the reaction of the phase-angle control on the line and protect the controller against line disturbances.

! The use of a suitable line filter is part of the standards conformity and a prerequisite of the CE mark.

ROPEX line filters are specially optimized for use in RESISTRON control loops. Providing that they are installed and wired correctly, they guarantee compliance with the EMC limit values.

You can find the exact specification of the line filter in the ROPEX Application Report calculated for your particular heatsealing application.

For more technical information: ↪ "Line filter" documentation.

It is permissible to supply several RESISTRON control loops with a single line filter, providing the total current does not exceed the maximum current of the filter.

The wiring instructions contained in section 5.3 "Power supply" on page 7 must be observed.

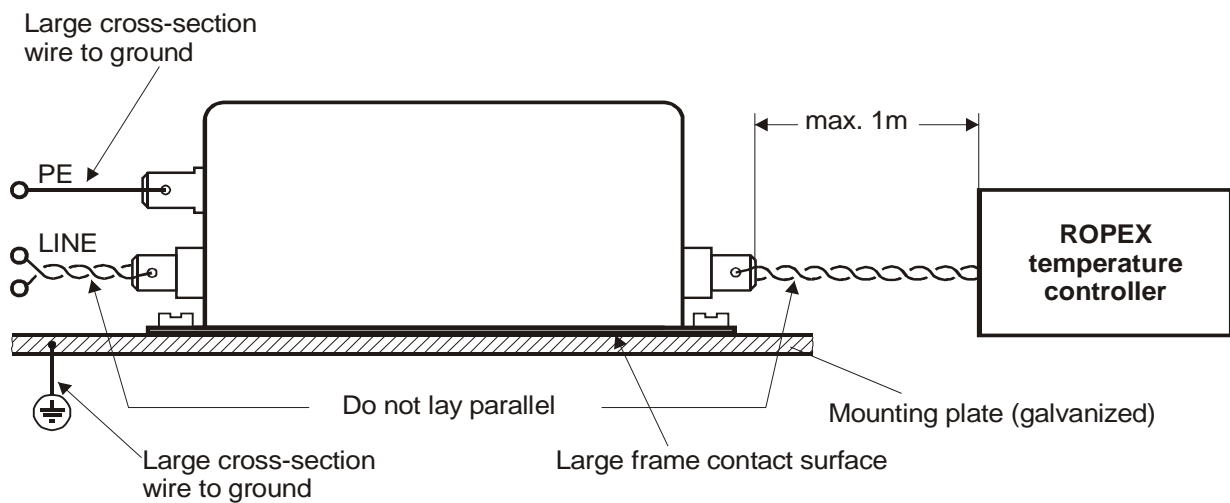

5.5 Current transformer PEX-W3/-W4

The PEX-W3/-W4 current transformer supplied with the RESISTRON temperature controller is an integral part

of the control system. The current transformer may only be operated if it is connected to the temperature controller correctly (↪ section 5.3 "Power supply" on page 7).

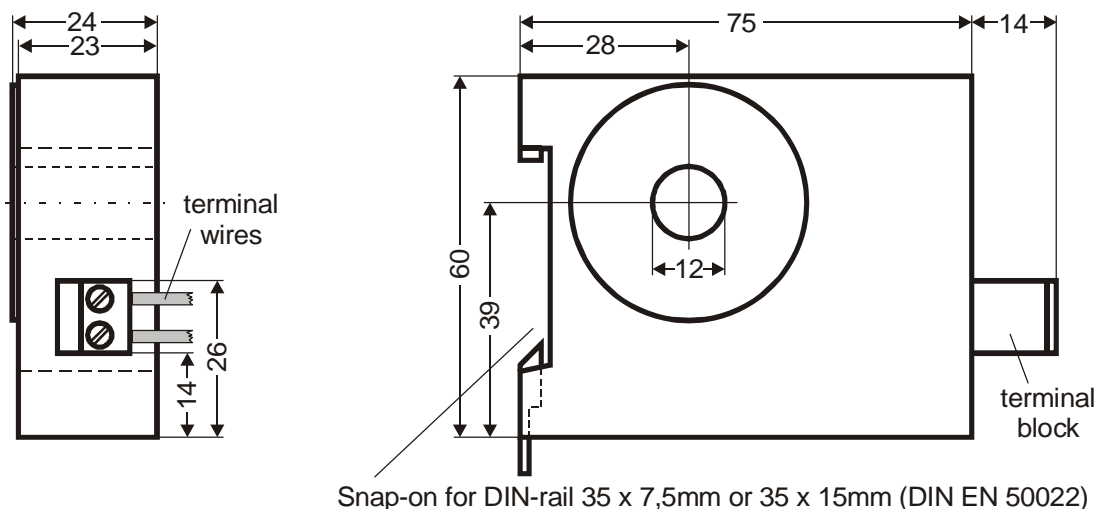

5.6 Wiring diagram

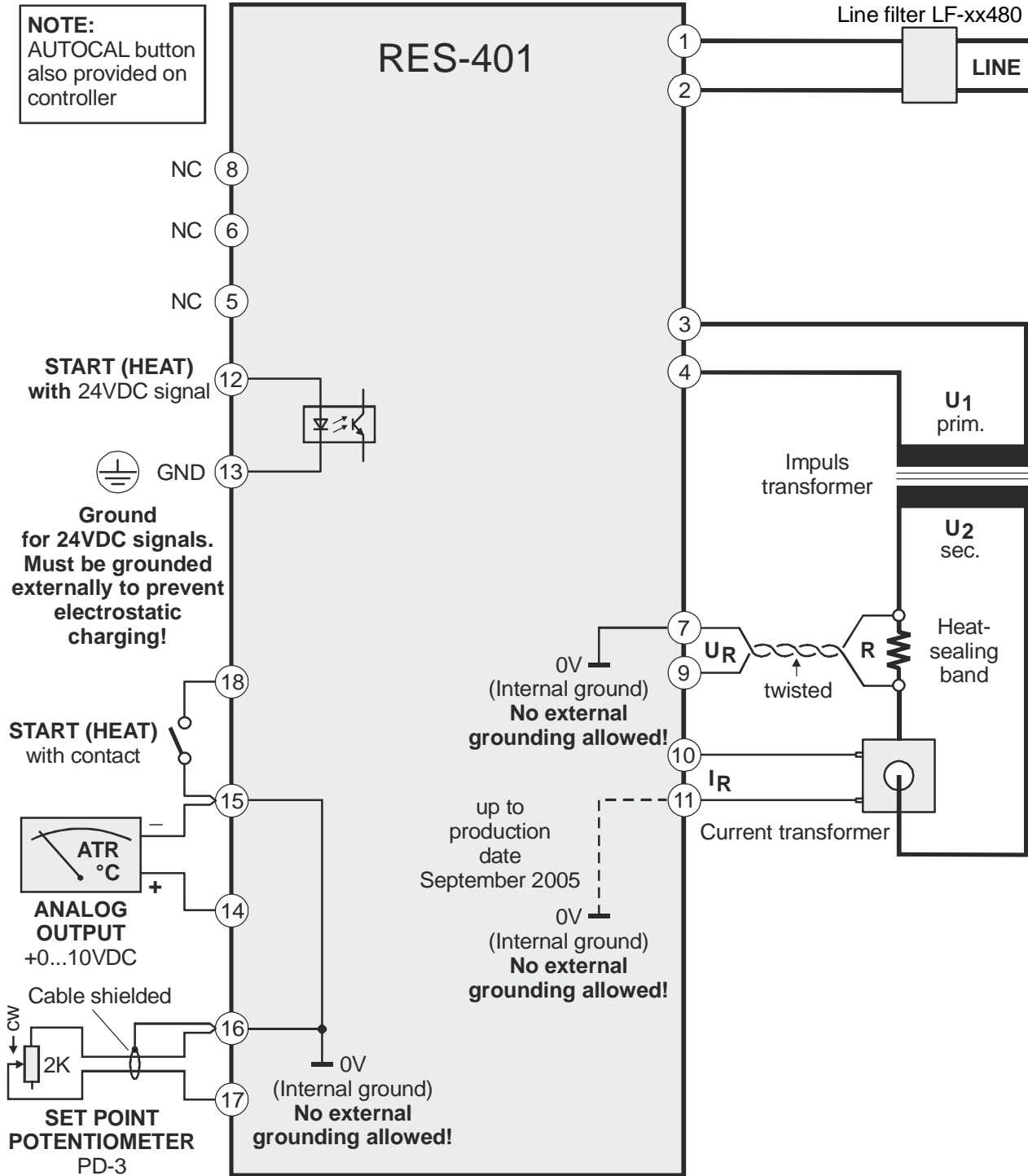

5.7 Startup and operation

5.8 View of the controller

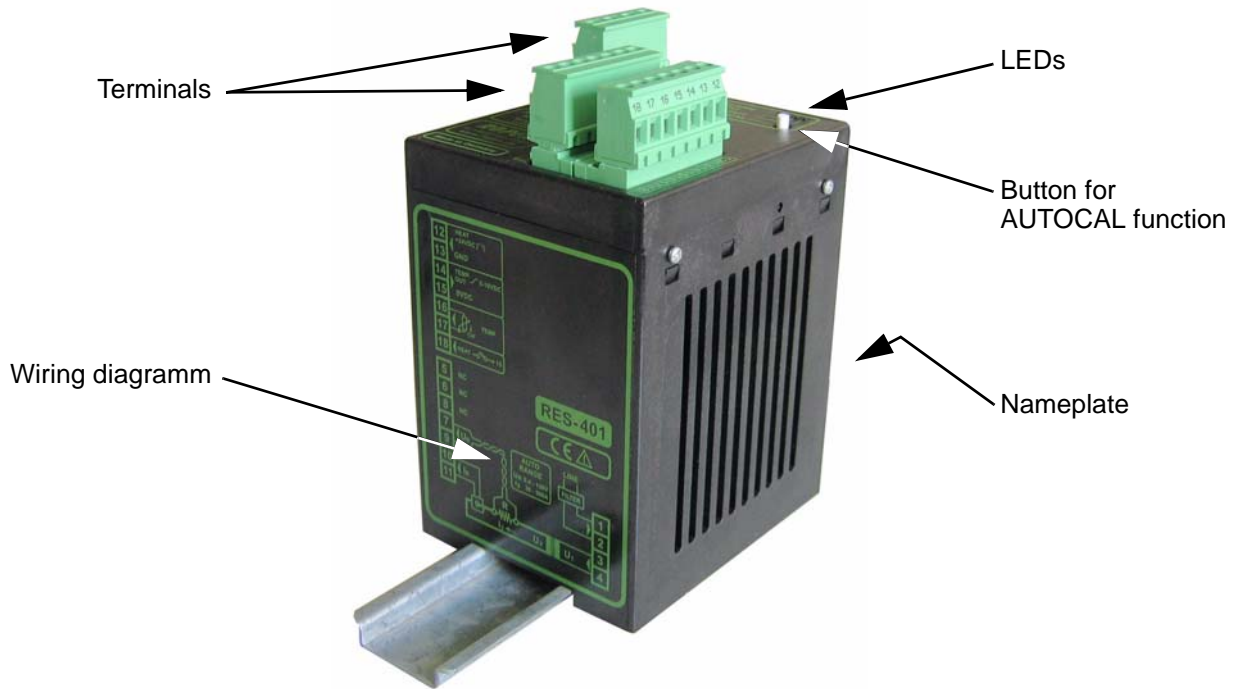

5.9 Controller configuration

! The controller must be switched off in order to configure the coding switches.

5.9.1 Configuration of the DIP switches for secondary voltage and current

**Automatic configuration (AUTORANGE)
(as of October 2005)**

The secondary voltage and current ranges are automatically configured by the automatic calibration

function (AUTOCAL). The voltage is configured in the range from 0.4VAC to 120VAC and the current in the range from 30A to 500A. If the voltage and/or the current is outside the permissible range, an error message appears on the controller (↪ see section 6.8 "Error messages" on page 19).

**Configuration with coding switches
(up to September 2005)**

Set the DIP switches for matching the secondary voltage U_2 and the secondary current I_2 to the correct position for **your** application.

You can find the exact configuration of the DIP switches in the ROPEX Application Report calculated for your particular application.

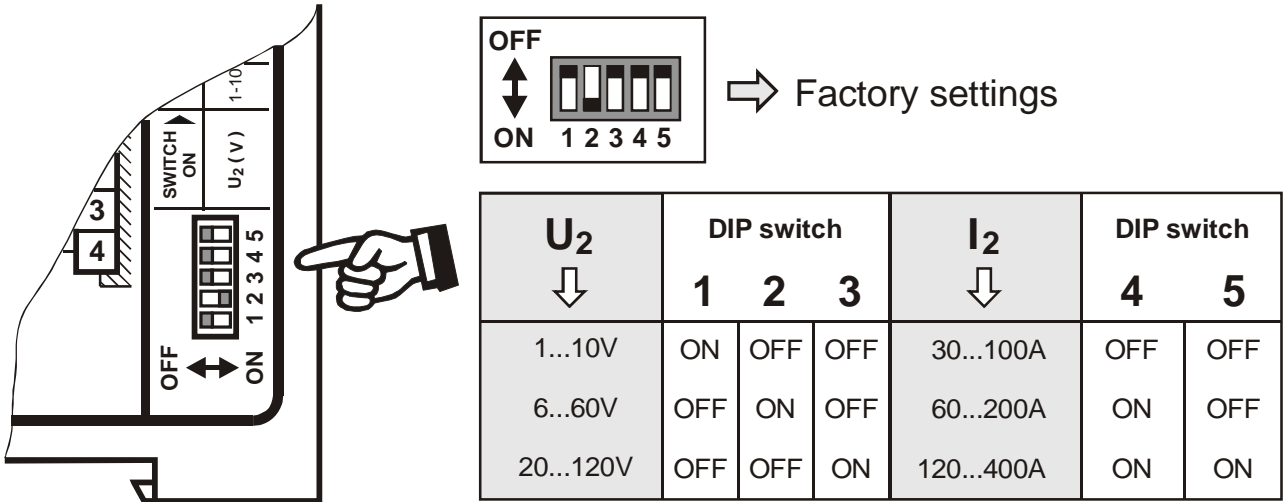

If the secondary current I_2 is less than 30A, the secondary high-current wire must be laid twice (or several

times) through the PEX-W3 or PEX-W4 current transformer (☞ ROPEX Application Report).



5.10 Replacing and "burning in" the heatsealing band

5.10.1 "Burning in" the heatsealing band

The heatsealing band is a key component in the control loop, since it is both a heating element and a sensor. The geometry of the heatsealing band is too complex to be discussed at length here. We shall therefore only refer to a few of the most important physical and electrical properties:

The measuring principle applied for this system necessitates a heatsealing band alloy with a suitable temperature coefficient TCR. Too low a TCR leads to oscillation or uncontrolled heating.

When heatsealing bands with a higher TCR are used, the controller must be calibrated for this.

The first time the heatsealing band is heated to approximately 200...250°C, the standard alloy undergoes a once-only resistance change (burn-in effect). The cold

resistance of the heatsealing band is reduced by approximately 2...3%. However, this at first glance slight resistance change results in a zero point error of 20...30°C. The zero point must therefore be corrected after a few heating cycles, i.e. the AUTOCAL function must be repeated.

The burn-in effect described here does not occur if the heatsealing band has already been thermally pretreated by the manufacturer.

⚠ An overheated or burned-out heatsealing band must no longer be used because the TCR has been altered irreversibly.

One very important design feature is the copper or silver-plating of the heatsealing band ends. Cold ends allow the temperature to be controlled accurately and increase the life of the teflon coating and the heatsealing band.

5.10.2 Replacing the heatsealing band

 **All power supply leads must be disconnected from the RESISTRON temperature controller in order to replace the heatsealing band.**

 **The heatsealing band must be replaced in accordance with the instructions provided by the manufacturer.**

Each time the heatsealing band is replaced, the zero point must be calibrated with the AUTOCAL function while the band is still cold, in order to compensate production-related resistance tolerances. The burn-in procedure described above should be performed for all new heatsealing bands.

5.11 Startup procedure

Please also refer to section 1 "General information" on page 3 and section 2 "Application" on page 4.

 **Installation and startup may only be performed by technically trained, skilled persons who are familiar with the associated risks and warranty provisions.**

5.11.1 Initial startup

Prerequisites: The controller must be correctly installed and connected (↪ section 5 "Installation" on page 5). Proceed as follows to start up the controller for the first time:

1. Switch off the line voltage and verify that all circuits are de-energized.
2. The supply voltage specified on the nameplate of the controller must be identical to the line voltage that is present in the plant or machine. The line frequency is automatically detected by the temperature controller in the range from 47...63Hz.
3. In the case of controllers manufactured up to September 2005, the settings of the DIP switches on the controller are indicated in the ROPEX Application Report and depend on the heatsealing band that is used (section 5.9 "Controller configuration" on page 10).
4. Make sure that no START signal is activated.
5. Switch on the line voltage.
6. When the voltage is switched on, the yellow "AUTOCAL" LED lights up for approximately 0.3 seconds to indicate that the controller is being

powered up correctly (up to September 2005: Twin-color LED lights up for 0.3s).

 **As of SW-Revision 106: If the red "ALARM" LED lights up for 0.3s in addition to the yellow "AUTOCAL" LED when the voltage is switched on, the configuration of this controller has been changed in the visualization software (↪ section 6.6 "Diagnostic interface/ visualization software (as of October 2005)" on page 19). In order to avoid malfunctions, please check the controller configuration before continuing the startup procedure.**

7. One of the following states then appears:
As of October 2005:

"ALARM" LED	"OUTPUT" LED	ACTION
OFF	Short pulses every 1.2s	Go to 8
BLINKS fast (4Hz)	OFF	Go to 8
Lit Continuously	OFF	Fault diagnosis (↪ sec. 6.8)

Up to September 2005:

LED	ACTION
Short pulses every 1.2s	Go to 8
BLINKS fast (4Hz) RED	Go to 8
Lit continuously RED	Fault, check controller configuration and installation (↪ sec. 6.7)

8. Activate the AUTOCAL function while the heatsealing band is still cold (with the manual button on the controller). The yellow "AUTOCAL" LED lights up (up to September 2005: Twin-color LED blinks red and green alternately) the duration of the calibration process (approx. 10...15s). A voltage of app. 0VDC appears at the same time at the actual value output (terminals 14+15). If an ATR-3 is connected, it indicates 0...3°C.

When the zero point has been calibrated, the "AUTOCAL" LED goes out (up to September 2005: The twin-color LED flashes green every 1.2s then) and a voltage of 0.66VDC appears at the actual

value output instead. If an ATR-3 is connected, it must be set to "Z".

If the zero point has not been calibrated successfully, the red "ALARM" LED blinks slowly (1Hz) (up to September 2005: Twin-color LED blinks red slowly). In this case the controller configuration is incorrect (↪ section 5.9 "Controller configuration" on page 10 and ROPEX Application Report). Repeat the calibration after the controller has been configured correctly.

9. When the zero point has been calibrated successfully, set a defined temperature on the set point potentiometer and activate the "START" signal (HEAT). The "HEAT" LED then lights up (up to September 2005: the twin-color LED "HEAT" then lights up). The heating and control process can be observed at the actual value output:

The controller is functioning correctly if the temperature (which corresponds to the signal change at the analog output) has a harmonious motion, in other words it must not jump abruptly, fluctuate or deviate temporarily in the wrong direction. This kind of beha-

avior would indicate that the U_R measuring wires have been wired incorrectly.

10. Burn in the heatsealing band (↪ section 5.10 "Replacing and "burning in" the heatsealing band" on page 11) and repeat the AUTOCAL function.

The controller is now
ready

5.11.2 Restart after replacing the heatsealing band

To replace the heatsealing band, proceed as described in section 5.10 "Replacing and "burning in" the heatsealing band" on page 11.

 **Always use a heatsealing band with the correct alloy, dimensions and copper-plating in order to avoid malfunctions and overheating.**

Continue with section 5.11.1 steps 4 to 10.

6 Controller functions

See also section 5.6 "Wiring diagram" on page 9.

6.1 Indicators and controls

Manufactured as of October 2005

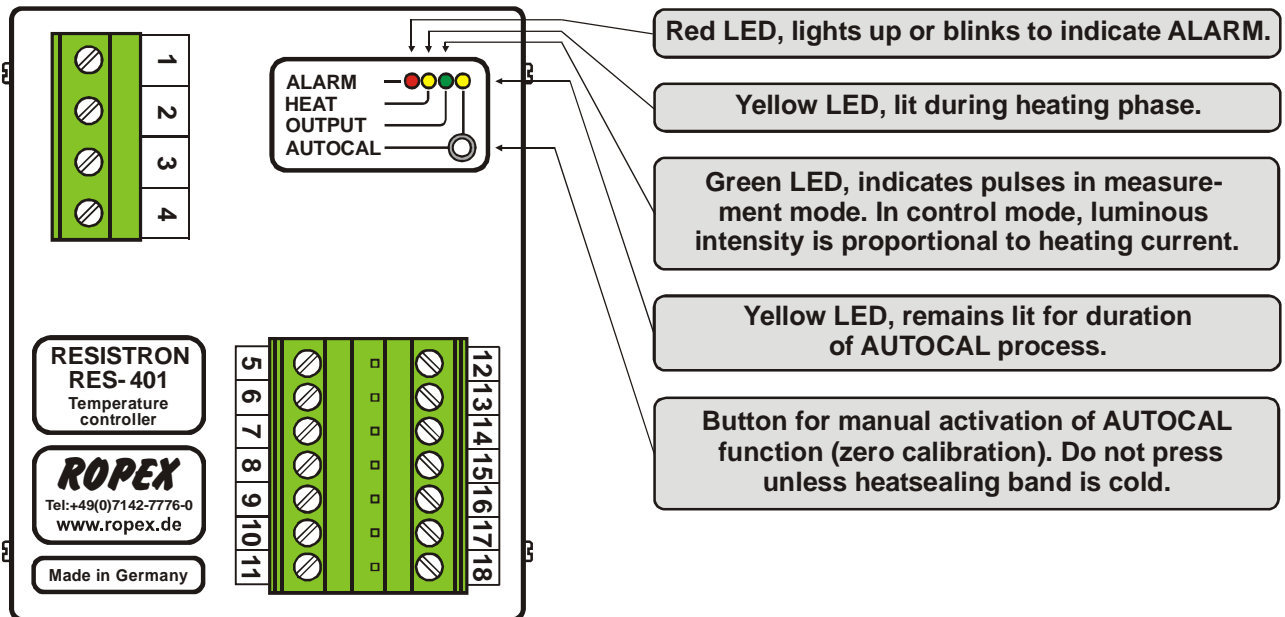

Manufactured up to September 2005

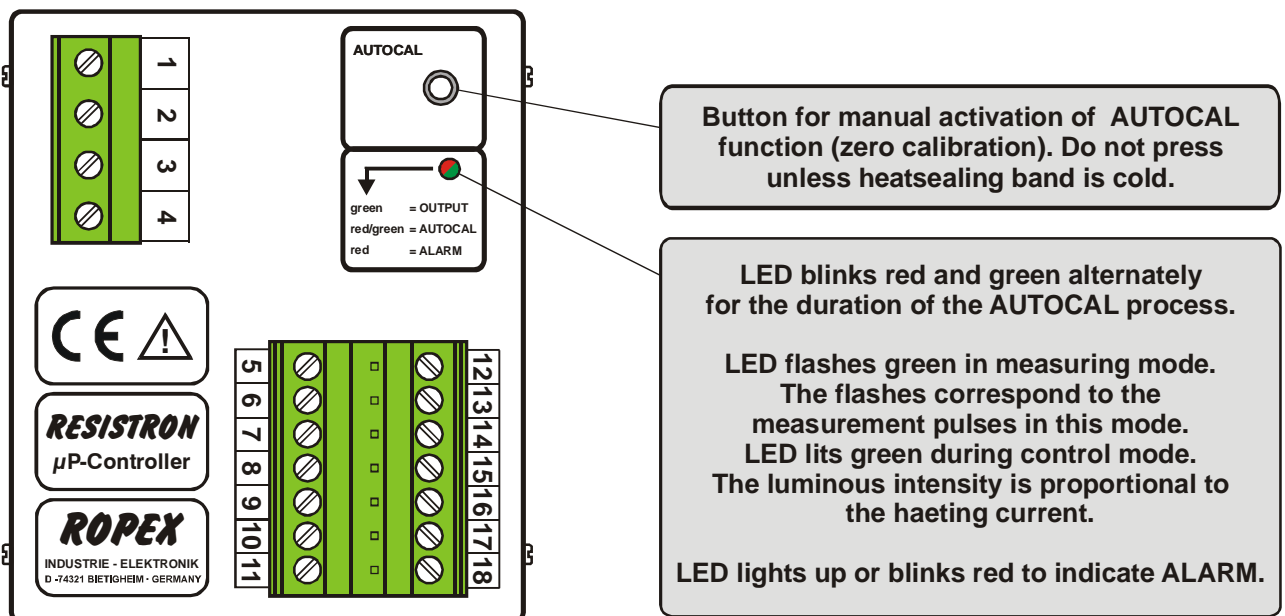

In addition to the functions shown in the diagram above, various controller operating states are indicated by the LEDs. These states are described in detail in the table below:

As of October 2005:

LED	Blinks slowly (1 Hz)	Blinks fast (4Hz)	Lit continuously
AUTOCAL (yellow)	RESET active, START and AUTOCAL functions are locked	AUTOCAL requested, but function disabled	AUTOCAL executing
HEAT (yellow)	—	START requested, but function disabled	START executing
OUTPUT (green)	In control mode the luminous intensity is proportional to the heating current.		
ALARM (red)	Configuration error, AUTOCAL not possible	Controller calibrated incor- rectly, run AUTOCAL	Fault, ↘ section 6.8

Up to September 2005:

LED	Meaning	Function
Blinks/lits green	In control mode the luminous intensity is proportional to the heating current.	Measure/Control mode
Blinks red/green alternately	AUTOCAL executing	AUTOCAL
Lit red for 1 s	AUTOCAL requested, but function disabled	
Blinks red slowly (1 Hz)	Configuration error, AUTOCAL not possible	ALARM
Blinks red fast (4Hz)	Controller calibrated incorrectly, run AUTOCAL	
Lit red continuously	Fault, check controller configuration and installation	

6.2 Temperature setting (set point selection)

wires between the controller and the potentiometer

The heatsealing temperature is set by means of a 2k Ω potentiometer at terminals 16+17. The connecting

must be shielded (↪ section 5.6 "Wiring diagram" on page 9).

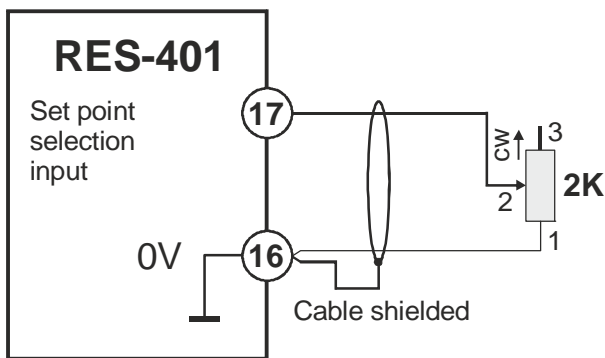

PD-3
Potentiometer P03
with
digital dial KD



Setting range:

0Ω → 0°C

2kΩ → 300°C (PD-3)

The relationship between the potentiometer setting and the SET temperature is linear.

! The terminals 16+17 are not potential-free and might have the potential of the secondary voltage of the impulse transformer.

! For the terminals of the external potentiometer touch voltage protection must be installed.

! External grounding is not allowed. If this warning is ignored, the controller will be damaged by frame currents.

If a ROPEX PD-3 precision potentiometer is used, the SET temperature can be adjusted exactly with the help of the digital display in the window of the dial. The number which appears on the display corresponds to the SET temperature in °C.

The set point that is selected for the heatsealing temperature must be greater than 40°C. If not, the heatsealing band will not be heated up when the "START" signal is activated.

! If a potentiometer is not connected, the set point is assumed to be zero. When you connect the potentiometer, please note the direction of rotation!

6.3 Temperature indication (actual value output)

The RES-401 supplies an analog 0...10VDC signal, which is proportional to the real ACTUAL temperature, at terminals 14+15.

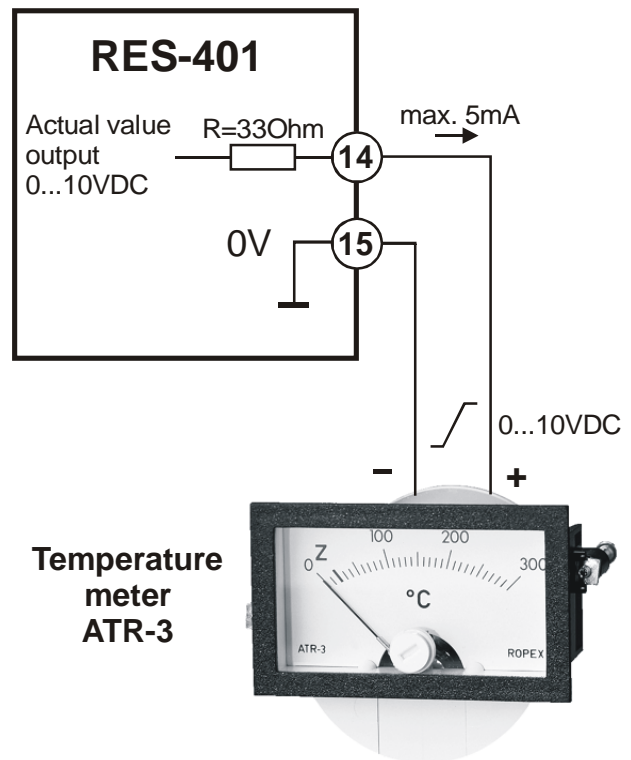

Voltage values:

0VDC → 0°C

10VDC → 300°C (ATR-3)

The relationship between the change in the output voltage and the ACTUAL temperature is linear.

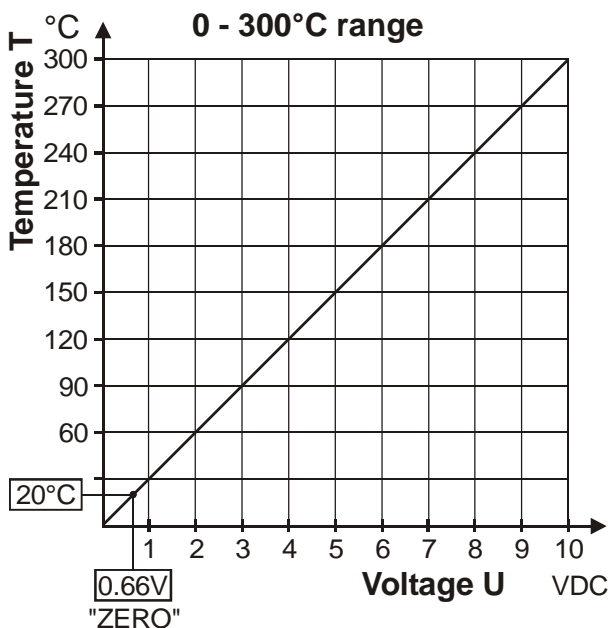

An indicating instrument can be connected to this output in order to visualize the temperature of the heatsealing band.

The characteristics of the ROPEX ATR-3 temperature indicator (size, scaling, dynamic response) are ideally suited to this application and this instrument should therefore always be used (↪ section 10 "Modifications (MODs)" on page 23).

It not only facilitates SET-ACTUAL comparisons, but also enables other criteria such as the heating rate, set point reached within the specified time, cooling of the heatsealing band etc. to be evaluated.

This indicator moreover permits disturbances in the control loop (loose connections, contacting or wiring problems) as well as any line disturbances to be observed extremely effectively and interpreted accordingly. The same applies if mutual interference occurs between several neighboring control loops.

⚠ This output is not potential-free and might have the potential of the secondary voltage of the impulse transformer.

⚠ External grounding is not allowed. If this warning is ignored, the controller will be damaged by frame currents.

⚠ For the terminals of the external temperature meter touch voltage protection must be installed.

If an alarm is signaled, the voltage at the analog output at terminals 14+15 changes between 0VDC and 10VDC with 1 Hz.

6.4 Automatic zero calibration (AUTOCAL)

Because of the automatic zero calibration (AUTOCAL) function, there is no need to adjust the zero point manually on the controller. This function matches the controller to the resistance of the system and calibrates it to a value of 20°C.

⚠ You should always wait for the heatsealing band and the bar to cool down (to ambient temperature) before activating the AUTOCAL function.

The AUTOCAL function is activated by pressing the AUTOCAL button on the controller.



The automatic calibration process takes about 10...15 seconds. The heatsealing band is not heated during this process.

The yellow LED on the front panel lights up when the AUTOCAL function is active (up to September 2005: Twin-color LED blinks red/green alternately). The actual value output (terminals 14+15) is 0...3°C (corresponds to app. 0 VDC) during this process.

If the temperature of the heatsealing band varies on controllers manufactured as of October 2005, the "AUTOCAL" function is executed a maximum of three times. If the function still cannot be terminated successfully, an error message appears (↪ section 6.8 "Error messages" on page 19).

⚠ You should always wait for the heatsealing band and the bar to cool down (to ambient temperature) before activating the AUTOCAL function.

Reasons for disabled AUTOCAL function:

1. The AUTOCAL function cannot be activated until 10 seconds after the controller is switched on. If you attempt to activate it sooner, it will not function.
2. The AUTOCAL function is not activated if the heat-sealing band is cooling down at a rate of more than 0.1K/sec. If the control signal is activated, the function is activated automatically providing the cooling rate has fallen below the above mentioned value.
3. If the "START" signal (24VDC) is active, the AUTOCAL function is not executed (as of October 2005: "HEAT" LED lit).
4. If the controller has already operated correctly - at least once - after starting up, the "AUTOCAL" function cannot be activated if the "ALARM" LED is lit continuously (up to September 2005: If the twin-color LED lit continuously).

! If the AUTOCAL function is disabled and if you attempt to activate it then the "AUTOCAL" LED blinks (up to September 2005: The twin-color LED lits red for 1 s (except case 4)).

6.5 "START" signal (HEAT)

When the "START" signal is activated, the controller-internal set/actual comparison is enabled and the heat-sealing band is heated up to the SET temperature. It remains at this temperature until the signal is deactivated.

As of October 2005: The "HEAT" LED on the front panel of the RES-401 is lit continuously for the duration of the heating phase.

The "START" signal can be activated in two ways:

- By means of a 24VDC signal at terminals 12+13

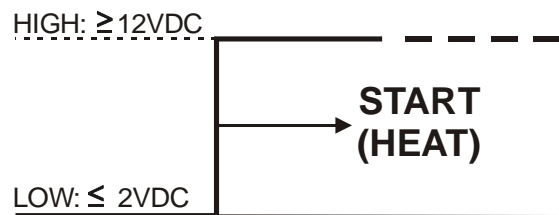
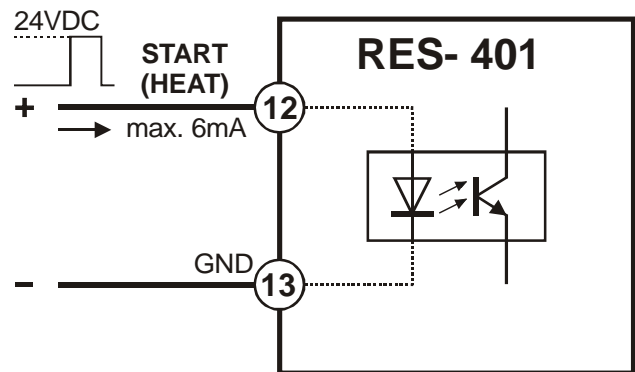

or

- By means of a control contact at terminals 15+18

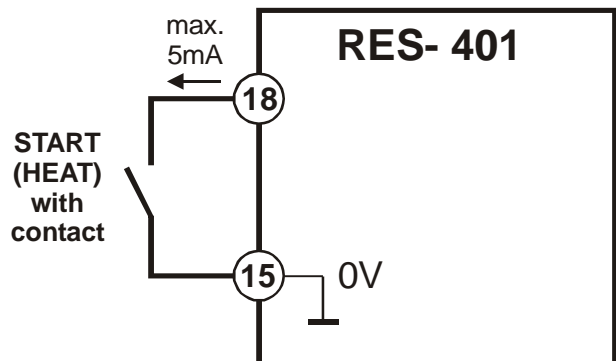

The "START" signal is disabled as long as the AUTOCAL function is executing (As of October 2005: "AUTOCAL" LED lit, "HEAT" LED blinks).

! The terminals 15+18 are not potential-free and might have the potential of the secondary voltage of the impulse transformer.

! For the terminals of the control contact touch voltage protection must be installed.

! External grounding is not allowed. If this warning is ignored, the controller will be damaged by frame currents.

The set point that is selected for the heatsealing temperature must be greater than 40°C. If not, the heatsealing band will not be heated up (as of October 2005: "HEAT" LED blinks).

6.6 Diagnostic interface/visualization software (as of October 2005)

An interface with a 6-pole Modular Jack (RJ-12) is provided for system diagnostics and process visualization. This interface allows a data connection to be set up to the ROPEX visualization software using the ROPEX communication interface CI-USB-1.

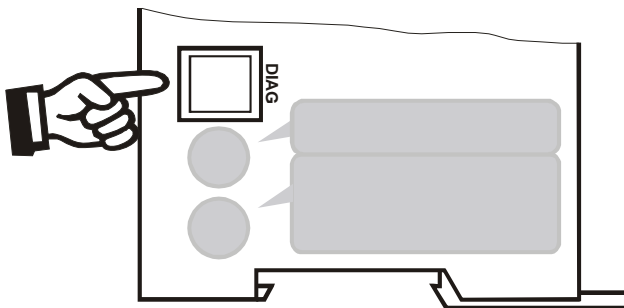

! Only a ROPEX communication interface is allowed to be connected to the diagnostic interface. Connecting another device (e.g. a telephone cable) could result in malfunctions or damage to the controller.

The ROPEX visualization software is described in a separate document.

6.7 System monitoring/alarm output

To increase operating safety and to avoid faulty heatsealing, this controller incorporates special hardware and software features that facilitate selective fault detection and diagnosis. Both the external wiring and the internal system are monitored.

A system fault is reported or differentiated by means of the following indications.

A.) Red "ALARM" LED on the controller three states:

1. **Blinks fast (4Hz)**
The AUTOCAL function should be executed.
2. **Blinks slowly (1 Hz)**
The system configuration is incorrect and the zero calibration (AUTOCAL function) was unsuccessful.
3. **Lit continuously:**
This indicates that a fault is preventing the controller from being started.
As a rule, it refers to an external wiring fault.

! An alarm can only be reset by switching the controller off and then on again.

6.8 Error messages

The RESISTRON temperature controller RES-401 indicates faults only by means of the LED. No additional error indication is available.

6.9 Fault areas and causes

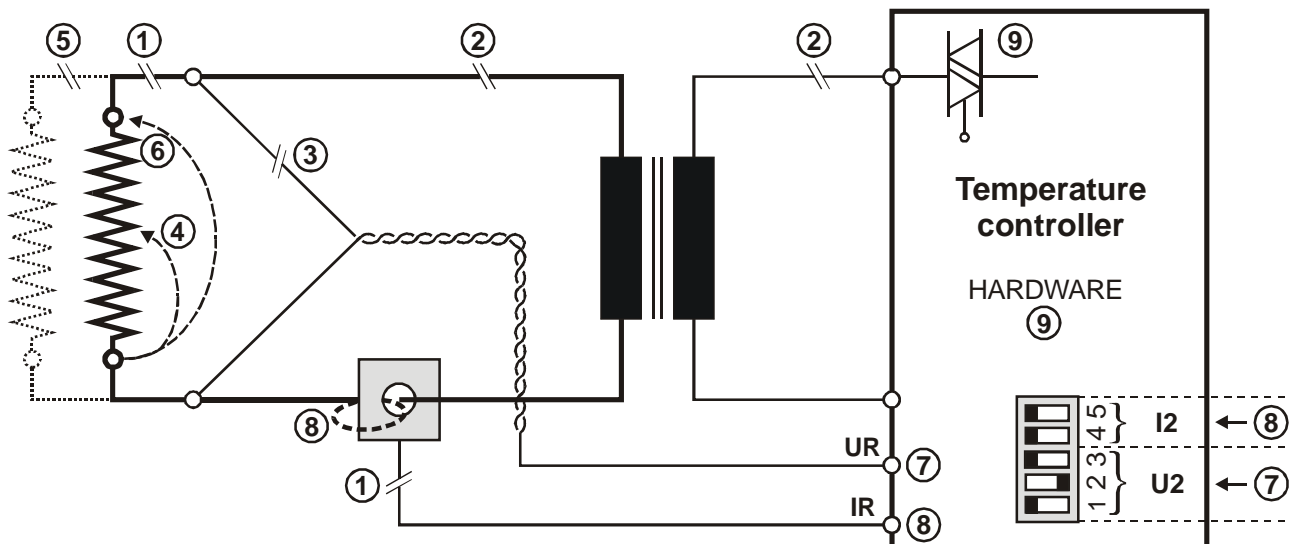

The table below explains the possible fault causes.

Fault area	Explanation	Possible causes
①	Load circuit interrupted after U_R pickoff point	- Wire break, heatsealing band break - Contact to heatsealing band defective
	Current transformer signal interrupted	- I_R measuring wires from current transformer interrupted
②	Primary circuit interrupted	- Wire break, triac in controller defective - Primary winding of impulse transformer interrupted
	Secondary circuit interrupted before U_R pickoff point	- Wire break - Secondary winding of impulse transformer interrupted
③	U_R signal missing	- Measuring wires interrupted
④	Partial short-circuit (ΔR)	- Heatsealing band partially bypassed by conducting part (clamp, opposite heatsealing bar etc.)
⑤	Parallel circuit interrupted	- Wire break, heatsealing band break - Contact to heatsealing band defective
⑥	Total short-circuit	- Heatsealing band installed incorrectly, insulation at heatsealing bar ends missing or incorrectly installed - Conducting part bypasses heatsealing band completely
⑦	U_R signal incorrect	- Up to September 2005: DIP switches 1 - 3 configured incorrectly (U_2 range) - As of October 2005: U_2 outside permissible range from 0.4...120VAC
⑧	I_R signal incorrect	- Up to September 2005: DIP switches 4 + 5 configured incorrectly (I_2 range) - As of October 2005: I_2 outside permissible range from 30...500A
	Turns through current transformer incorrect	- Check number of turns (two or more turns required for currents < 30A)
⑨	Internal controller fault	- Hardware fault (replace controller)

7 Factory settings

The RESISTRON temperature controller RES-401 is configured in the factory as follows:

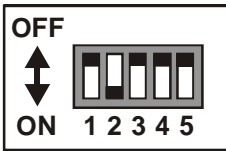
<p><u>DIP switches</u> for secondary voltage U_2 and current I_2 (up to September 2005)</p>		<p>$U_2 = 6...60VAC$ $I_2 = 30...100A$</p> <p>DIP switches: 2 ON 1, 3, 4, 5 OFF</p> <p>These switches are automatically set by the AUTORANGE function on all controllers manufactured as of October 2005.</p>
---	---	--

8 Technical data

Type of construction	Housing for installation in the electrical cabinet Snaps onto a standard top hat rail (DIN TS35 rail, 35 mm) acc. to DIN EN 50022 Dimensions: 90 x 75mm; height: 135mm (incl. terminals)
Line voltage	<p><u>All controllers manufactured as of October 2005:</u> 115VAC version: 110VAC -15%...120VAC +10% (equivalent to 94...132VAC) 230VAC version: 220VAC -15%...240VAC +10% (equivalent to 187...264VAC) 400VAC version: 380VAC -15%...415VAC +10% (equivalent to 323...456VAC)</p> <p><u>All controllers manufactured as of January 2004 up to September 2005:</u> 115VAC version: 115VAC -15%...120VAC +10% (equivalent to 98...132VAC) 230VAC version: 230VAC -15%...240VAC +10% (equivalent to 196...264VAC) 400VAC version: 400VAC -15%...415VAC +10% (equivalent to 340...456VAC)</p> <p><u>All controllers manufactured up to December 2003:</u> 115VAC, 230VAC or 400VAC, tolerance: +10% / -15%</p> <p>depending on version selected (↙ section 11 "How to order" on page 24)</p>
Line frequency	47...63Hz, automatic adjustment to frequencies in this range
Heatsealing band type and temperature range	Temperature coefficient 1100ppm, 0...300°C (e.g. Alloy-A20)
Set point selection Terminals 16+17	With an external PD-3 precision potentiometer (R = 2kΩ) 0...2kΩ, equivalent to 0...300°C
Analog output (actual value) Terminals 14+15	0...10VDC, I _{max} = 5mA Equivalent to 0...300°C Accuracy: ±1% add. 50mV
Digital logic levels Terminals 8, 12, 13	LOW (0V): 0...2VDC HIGH (24VDC): 12...30VDC (max. current input 6mA) Reverse polarity-protected
Maximum load (primary current of impulse transformer)	I _{max} = 5A (duty cycle = 100%) I _{max} = 25A (duty cycle = 20%)
Power dissipation	max. 20W
Ambient temperature	+5...+45°C
Degree of protection	IP20

<p>Installation</p>	<p>If several controllers are installed on one top hat rail (DIN TS35 rail), a clearance of at least 20mm should be allowed between them.</p> <p>The moving clip required for fastening must be facing down for mounting on a horizontal top hat rail.</p> <p>End holders to mechanical fix the controller must be fitted at both ends for mounting on a vertical top hat rail.</p>	
<p>Weight</p>	<p>Approx. 0.7kg (incl. connector plug-in parts)</p>	
<p>Housing material</p>	<p>Plastic, polycarbonate, UL-94-V0</p>	
<p>Connecting cables Type / cross-sections</p>	<p>Rigid or flexible; 0.2...2.5mm² (AWG 24...12) Plug-in</p> <p>⚠ If ferrules are used, they must be crimped in accordance with DIN 46228 and IEC/EN 60947-1. This is essential for proper electrical contact in the terminals.</p>	

9 Dimensions

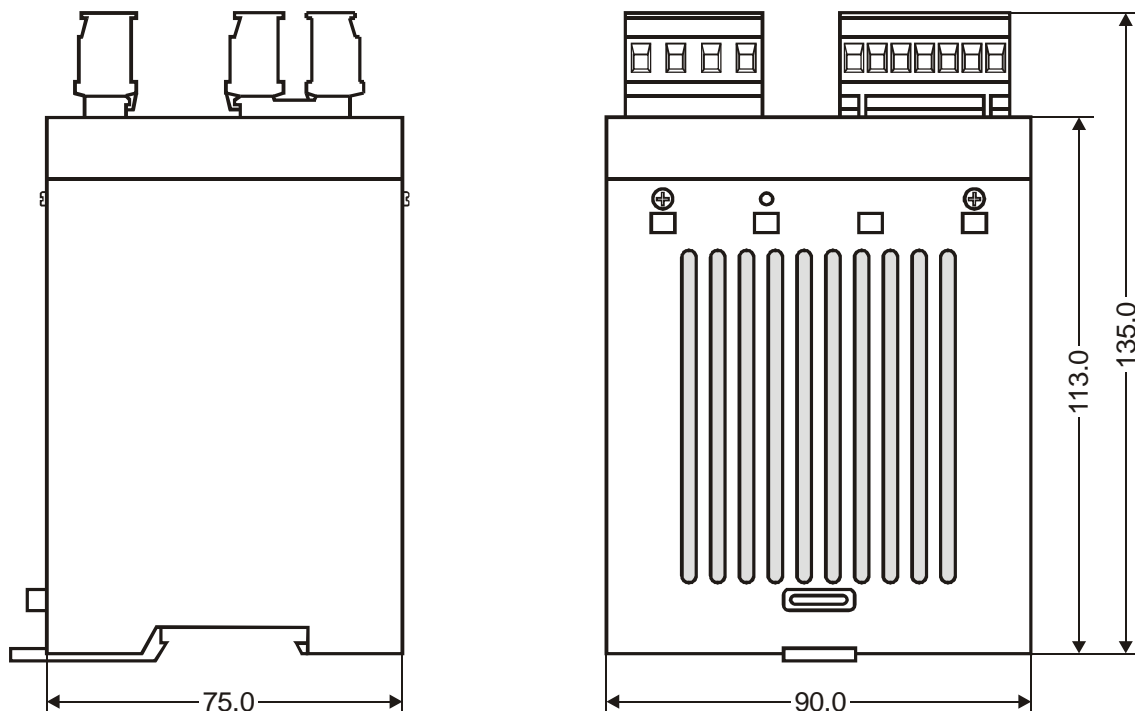

10 Modifications (MODs)

Modifications are not available for the RES-401.

11 How to order

Pictures exemplary.

	<p>Contr. RES - 401 / . . . VAC</p> <ul style="list-style-type: none"> 115: Power supply 115VAC, P/N 740101 230: Power supply 230VAC, P/N 740102 400: Power supply 400VAC, P/N 740103 <p>Scope of supply: Controller includes connector plug-in parts (without current transformer)</p> <p>Please indicate the article numbers in all orders.</p>
	<p>Current transformer PEX-W4 P/N 885106</p>
	<p>Line filter LF- . . . 480</p> <ul style="list-style-type: none"> 06: Continuous current 6A, 480VAC, P/N 885500 35: Continuous current 35A, 480VAC, P/N 885506
	<p>Impulse transformer</p> <p>See ROPEX Application Report for design and ordering information</p>
	<p>Communication interface CI-USB-1 P/N 885650</p>
	<p>Potentiometer PD- 3: For 300°C range, P/N 881103 Scope of supply: Potentiometer with digital dial</p>
	<p>Temp. meter ATR- 3: 300°C range, P/N 882130</p>

For more accessories: ↗ "Accessories" leaflet

12 Index

A

Actual value output 16
Alarm output 19
Alloy 13
Ambient temperature 22
Application 4
Application Report 6, 8, 11
AUTOCAL 5, 12, 17
Automatic zero calibration 5, 12, 17
AUTOTUNE 5

B

Burning in the heatsealing band 11, 13

C

Circuit-breaker 7
CI-USB-1 19, 24
Communication interface 19, 24
Controller configuration 10
Controls 14
Current transformer 8, 24

D

Degree of protection 22
Diagnostic interface 19
Dimensions 23
DIP switches 10
Disposal 4

E

Error messages 19

F

Factory settings 21
Fault areas 19
Fault diagnosis 5
Fuse 7

H

HEAT 13, 18
Heatsealing band type 22
How to order 24

I

Impulse heatsealing method 4
Impulse transformer 7, 24
Installation 5, 23
Installation procedure 5
Installation regulations 6

L

Line filter 4, 7, 8, 24

Line frequency 5, 22
Line voltage 22

M

Maintenance 4
Modifications 23
MODs 23

O

Over-current protection 7
Overheating of heatsealing band 5

P

PEX-W3/-W4 3, 8
PEX-W4 24
Potentiometer 15, 24
Power dissipation 22
Power supply 7, 24
Principle of operation 5

R

Replacing the heatsealing band 12, 13

S

Secondary current I_2 10
Secondary voltage U_2 10
Set point potentiometer 15
Set point selection 15, 22
"START" signal 13, 18
Startup 10
System diagnostics 19
System monitoring 19

T

TCR 3, 11
Technical data 22
Temperature coefficient 3, 11
Temperature control 4
Temperature indication 16, 17
Temperature meter 24
Temperature range 22
Temperature setting 15
Transformer 3, 7, 24
Type of construction 22

V

View of the controller 10
Visualization software 19

W

Wiring 6, 7
Wiring diagram 9